



Superior Clamping and Gripping



Product Information

Universal gripper PGN-plus-P

PGN-plus-P

Universal gripper

Reliable. Robust. Flexible.

Universal gripper PGN-plus-P

Universal 2-finger parallel gripper with permanent lubrication, high gripping force, and high maximum moments due to the use of a multi-tooth guidance.

Field of application

Pneumatic universal gripper for handling of workpieces in universal applications. For universal use in clean to slightly dirty environments. Special versions available for dirty environments.

Advantages – Your benefits

Robust multi-tooth guidance for precise handling

High maximum moments possible suitable for using long gripper fingers

Lubricant pockets in the multi-tooth guidance ensure process reliability and extended maintenance intervals

Maximum piston surface area for maximum gripping forces

Mounting from two sides in three screw directions for universal and flexible gripper assembly

Air supply via hose-free direct connection or screw connections for universal and flexible gripper assembly

Comprehensive sensor accessory program for versatile querying possibilities and stroke position monitoring

Manifold options for special optimization for your specific case of application (dustproof, high-temperature, corrosion-protected, etc.)



Sizes
Quantity: 11



Weight
0.08 .. 39.8 kg



Gripping force
180 .. 26100 N



Stroke per jaw
2 .. 45 mm



Workpiece weight
0.9 .. 97.5 kg

Functional description

The piston is moved up and down by compressed air. The angled active surfaces of the wedge-hook produce a synchronized, parallel jaw motion.

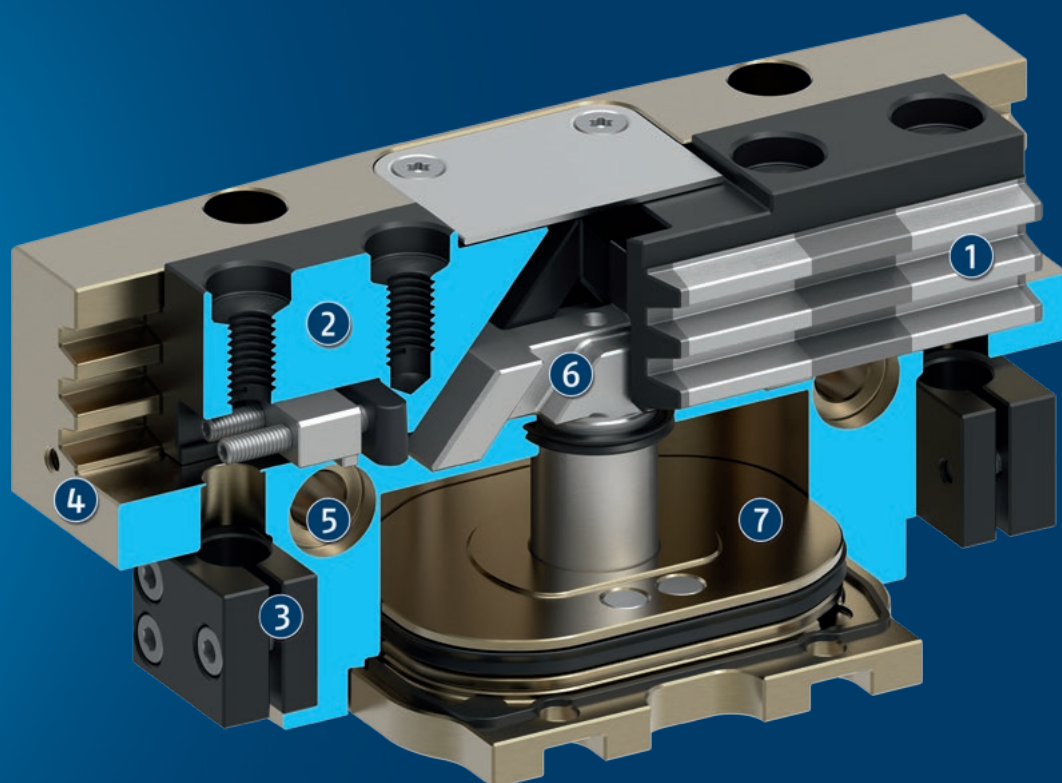

- ① **Multi-tooth guidance**
Maximum service life due to lubricant pockets in the robust multi-tooth guidance, and absorption of high forces and torques by means of the large guidance support
- ② **Base jaw**
with standardized screw connection diagram for the connection of the workpiece-specific gripper fingers
- ③ **Bracket for sensors**
Brackets for proximity switches and adjustable control cams in the housing
- ④ **Housing**
is weight-optimized due to the use of high-strength aluminum alloy
- ⑤ **Centering and mounting possibilities**
for universal assembly of the gripper
- ⑥ **Wedge-hook design**
for high power transmission and minimal wear as a result of larger diagonal pull surfaces
- ⑦ **Piston**
Maximum force through maximum surface of drive piston

Detailed functional description

Dustproof version SD



The "dustproof" option increases the degree of protection against penetrating substances. This can either be ordered in a ready-mounted gripper version or else retrofitted to the gripper using the "SAD PGN-plus-P" retrofit kit.

Gripping force maintenance version AS/IS

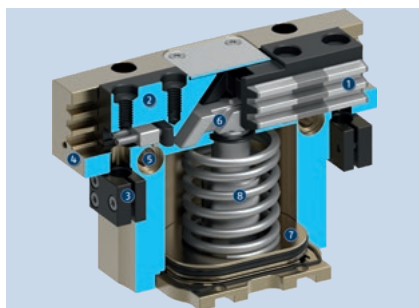

The mechanical gripping force maintenance device ensures that a minimum clamping force will be applied even if there is a drop in pressure. In the AS version this acts as a closing force, and in the IS version as an opening force. The image shows the AS version. The gripping force maintenance can also be used to increase the gripping force or for one-way gripping.

- ❶ Multi-tooth guidance
- ❷ Base jaw
- ❸ Bracket for sensors
- ❹ Housing
- ❺ Centering and mounting possibilities
- ❻ Wedge-hook design
- ❼ Piston
- ❽ Gripping force maintenance device

Settings of the control cams during monitoring with inductive proximity switches

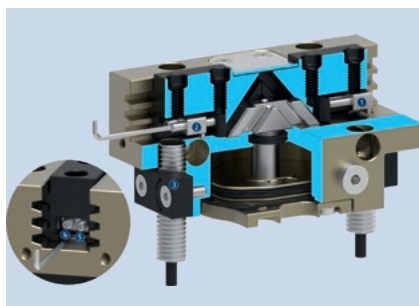

Monitoring with inductive proximity switch can be performed as standard from size 64. In delivery state, the positions "gripper open" and "gripper closed" are preset with the control cams. The inductive sensors must be ordered separately and are slid into the housing up to the stop and clamped. In order to monitor any other position, such as "workpiece gripped" for example, both control cams can be individually set in the respective base jaws.

- ❶ Control cam preset for "gripper closed" position
- ❷ Control cam preset for "gripper open" position
- ❸ Holder with clamping screw for fixing the sensor
- ❹ Clamping screw for process-reliable fixing of the adjusted switching point
- ❺ Adjusting screw for setting any switching point

Optional mounting possibility under the cover sheet for customer-specific additional structure

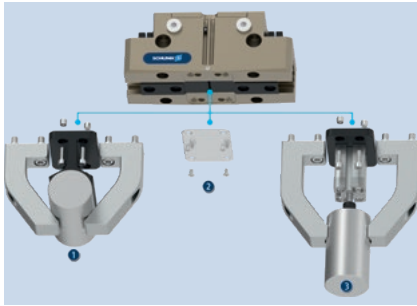

In delivery state, a cover sheet is mounted to the gripper. This can be removed if necessary. Under the cover sheet are threads and fittings for mounting customer-specific designs for implementing additional functions.

- ❶ Additional centering or support of the workpiece
- ❷ The cover plate (can be removed)
- ❸ Ejector with external cylinder attached to the gripper

PGN-plus-P

Universal gripper

General notes about the series

Operating principle: Wedge gear with surface power transmission

Housing material: Aluminum

Base jaw material: Steel

Actuation: pneumatic, with filtered compressed air as per ISO 8573-1:2010 [7:4:4].

Warranty: 36 months

Service life characteristics: on request

Scope of delivery: Brackets for proximity switches, centering sleeves, O-rings for direct connection, assembly instructions (operating manual with declaration of incorporation is available online)

Gripping force maintenance device: possible by using the version with mechanical gripping force maintenance or pressure maintenance valve SDV-P

Gripping force: is the arithmetic sum of the individual force applied to each jaw at distance P (see illustration).

Finger length: is measured from the reference surface as the distance P in direction to the main axis.

The maximum permissible finger length applies until the nominal operating pressure is achieved. With higher pressures, the finger length must be reduced proportionally to the nominal operating pressure.

Repeat accuracy: is defined as a distribution of the end Position for 100 consecutive strokes.

Workpiece weight: is calculated for force-fit gripping with a coefficient of static friction of 0.1 and a safety factor of 2 against workpiece slippage at acceleration due to gravity g. For form-fit or capture gripping, there are significantly higher permissible workpiece weights.

Closing and opening times: are purely the times that the base jaws or fingers are in motion. Valve switching times, hose fill times, or PLC reaction times are not included, and are to be considered when cycle times are calculated.

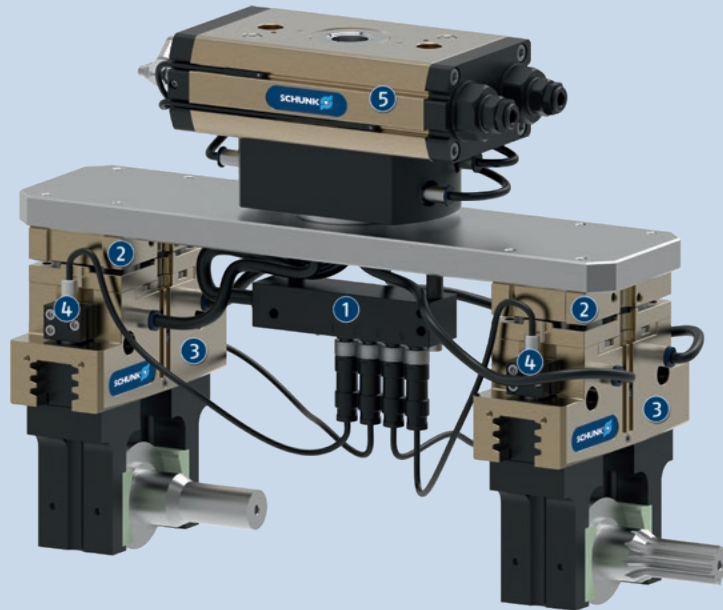

Application example

Handling tool for loading and unloading raw and finished parts and compensation of inaccurate position. A sensor distributor is used for routing signals through a cable.

- ① Sensor distributor V4
- ② Tolerance compensation unit TCU-Z
- ③ Universal gripper PGN-plus-P
- ④ IN sensors
- ⑤ Universal rotary actuator SRM

SCHUNK offers more ...

The following components make the product even more productive – the suitable addition for the highest functionality, flexibility, reliability, and controlled production.



Rotary unit



Quick change system



Compensation unit



Linear module



Jaw quick-change system



Finger blank



Pressure maintenance valve



Universal intermediate jaw



Flexible position sensor



Analog position sensor



Magnetic switches



Inductive proximity switches

① For more information on these products can be found on the following product pages or at schunk.com.

Options and special information

Gripping force maintenance version AS/IS: The mechanical gripping force maintenance version ensures minimum gripping force even in the event of a pressure drop. In the AS/IS version this acts as a closing force, in the IS version as an opening force.

High-temperature version VHT: for use in hot environments

Precision version P: for the highest accuracy

Anti-corrosion version K: for use in corrosion-inducing atmospheres

ATEX version EX: for explosive environments

Dustproof version SD: absolutely dustproof, increased degree of protection against ingress of materials.

Integrated air purge connection: impedes the ingress of dirt into the inside of the gripper

NEW: Version with food-compliant lubrication (H1G): as a solution for an easy entry into medical technology, lab automation, pharmaceutical and food industry. The requirements of EN 1672-2:2020 are not fully met.

Additional versions: Various options can be combined with each other.

PGN-plus-P

Universal gripper

SCHUNK gripper PGN-plus-P

Overview Accessories

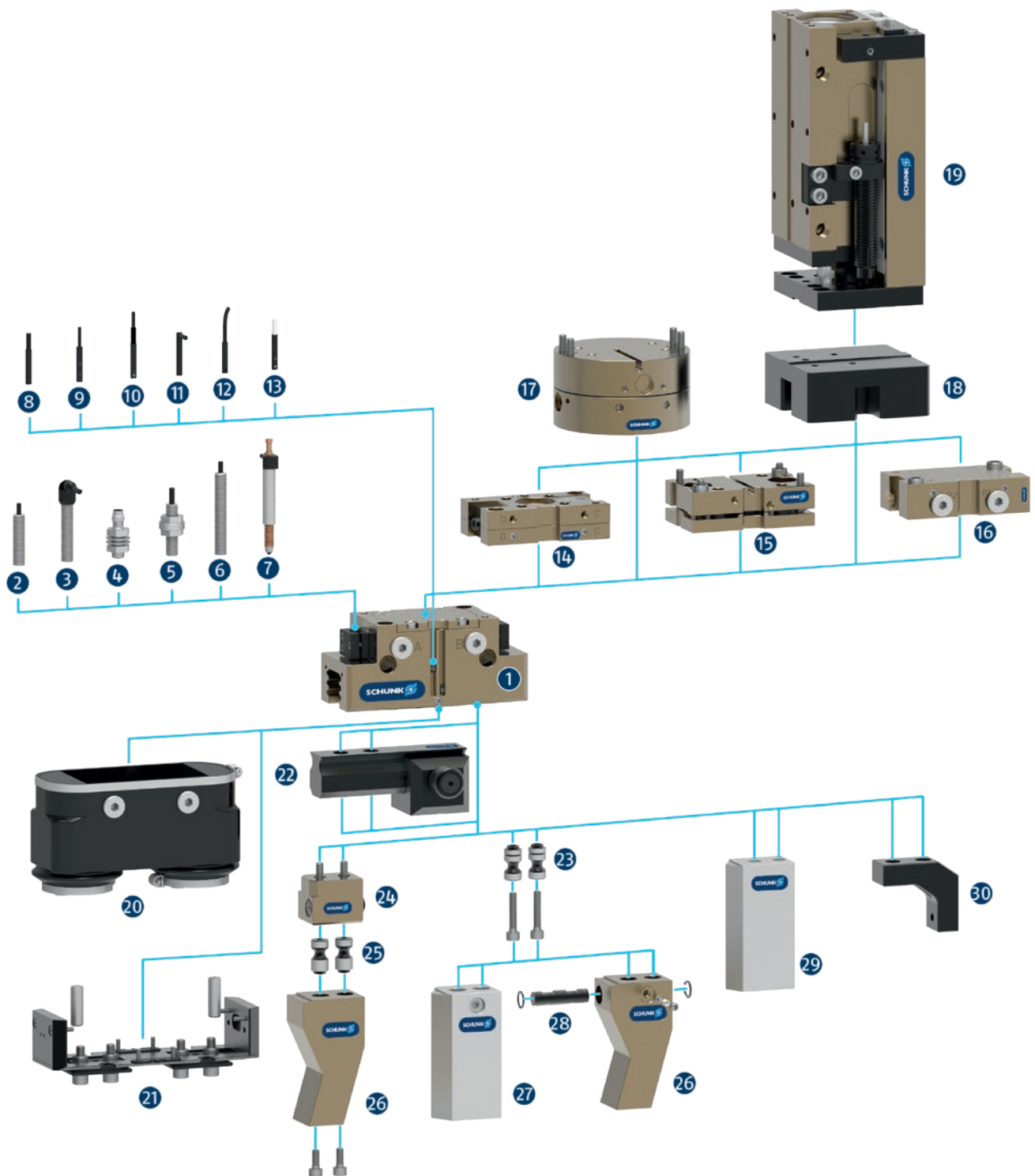

- 1 **PGN-plus-P**
Universal 2-finger parallel gripper with a high gripping force and high maximum moments due to the use of a multi-tooth guidance

Sensor system

- 2 **IN ...**
Inductive proximity switch with molded cable and straight cable outlet
- 3 **IN ...-SA**
Inductive proximity switch with molded cable and lateral cable outlet
- 4 **IN-C 80**
Inductive proximity switch, directly pluggable
- 5 **FPS**
Flexible position sensor for monitoring up to five different, freely selectable positions
- 6 **APS-Z80**
Inductive position sensor for precise position detection of the gripper jaws with analog output
- 7 **APS-M1S**
Mechanical measuring system for precise position detection of the gripper jaw with analog output
- 8 **MMS 22**
Magnetic switch with straight cable outlet for monitoring a position

MMS 22-PI1
Magnetic switch with straight cable outlet for monitoring a freely programmable position
- 9 **MMS 22-PI2**
Magnetic switch with straight cable outlet for monitoring two freely programmable positions
- 10 **MMS 22-PI1-HD**
MMS 22-PI1 in robust design

MMS 22-PI2-HD
MMS 22-PI2 in robust design
- 11 **MMS 22-SA**
Magnetic switch with lateral cable outlet for monitoring a position

MMS 22-PI1-SA
Magnetic switch with side cable outlet for monitoring a freely programmable position
- 12 **MMS-P**
Magnetic switch with straight cable outlet for monitoring two freely programmable positions
- 13 **MMS-A**
Analog magnetic switch with straight cable outlet for measuring the gripper jaw position with analog output and teach function

Complementary products

- 14 **CWS**
Manual change system with integrated air feed-through for simple exchange of the handling components
- 15 **TCU**
Tolerance compensation unit for compensating small tolerances in the plane
- 16 **SDV-P-E-P**
Pressure maintenance valve for temporary force and position maintenance
- 17 **AGE**
Compensation unit for compensation of large tolerances along the X and Y axes
- 18 **ASG**
Adapter plate for combining various automation components in the modular system
- 19 **CLM**
Linear module with pneumatic drive and scope-free pre-loaded junction rollers
- 20 **HUE**
Sleeve for protection against dirt
- 21 **SAD**
Dustproof version, retrofit kit

Finger Accessories

- 22 **UZB**
The universal intermediate jaw allows fast tool-free and reliable plugging and shifting of top jaws at the gripper.
- 23 **BSWS-AR**
Adapter pin of the jaw quick-change system for fast, manual change of top jaws
- 24 **BSWS-B**
Locking mechanism of the jaw quick-change system for fast, manual exchange of top jaws
- 25 **BSWS-A**
Adapter pin of the jaw quick-change system for adaptation to the customized finger
- 26 **Customized fingers**
- 27 **BSWS-ABR**
Finger blank made of aluminum with interface to the jaw quick-change system

BSWS-SBR
Finger blank made of steel with interface to the jaw quick-change system
- 28 **BSWS-UR**
Locking mechanism for the integration of the jaw quick-change system into customized fingers
- 29 **ABR/SBR**
Finger blanks made of steel or aluminum with standardized screw connection diagram
- 30 **ZBA**
Intermediate jaws for reorientation of the mounting surface

PGN-plus-P 40

Universal gripper



Gripping force O.D. gripping

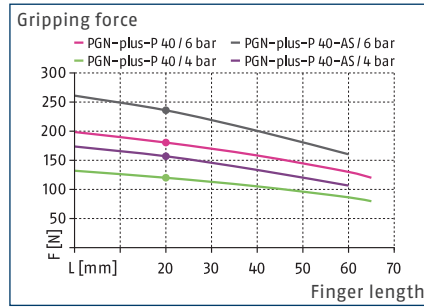

Gripping force I.D. gripping

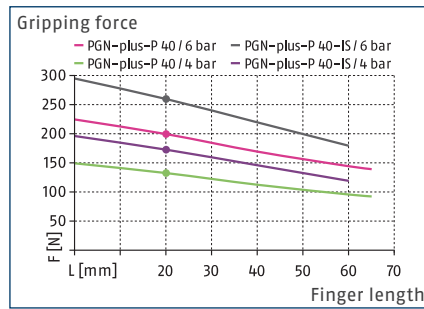

Dimensions and maximum loads

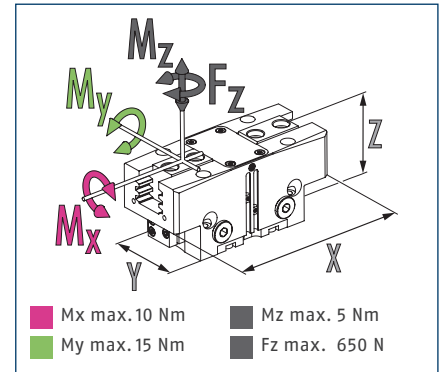

① The indicated moments and forces are static values, apply for each base jaw and may appear simultaneously. Loads may additionally occur to the moment produced by the gripping force itself.

Technical data

Description		PGN-plus-P 40	PGN-plus-P 40-AS	PGN-plus-P 40-IS
ID		0318448	0318450	0318452
Stroke per jaw	[mm]	2.5	2.5	2.5
Closing/opening force	[N]	180/200	235/-	-/260
Min. spring force	[N]		55	60
Weight	[kg]	0.08	0.1	0.1
Recommended workpiece weight	[kg]	0.9	0.9	0.9
Fluid consumption double stroke	[cm ³]	4	8	10
Min./nom./max. operating pressure	[bar]	2.5/6/8	4/6/6.5	4/6/6.5
Min./max. air purge pressure	[bar]	0.5/1	0.5/1	0.5/1
Closing/opening time	[s]	0.015/0.015	0.015/0.03	0.03/0.015
Closing/opening time with spring	[s]		0.03	0.03
Max. permissible finger length	[mm]	65	60	60
Max. permissible weight per finger	[kg]	0.12	0.12	0.12
IP protection class		40	40	40
Min./max. ambient temperature	[°C]	5/90	5/90	5/90
Repeat accuracy	[mm]	0.01	0.01	0.01
Dimensions X x Y x Z	[mm]	50 x 25 x 24.7	50 x 25 x 33.7	50 x 25 x 33.7
Options and their characteristics				
Dustproof version		1317458	1317463	1317466
IP protection class		64	64	64
Weight	[kg]	0.1	0.12	0.12
Corrosion-protected version		1317436	1317437	1317439
High-temperature version		1317423	1317428	1317431
Min./max. ambient temperature	[°C]	5/130	5/130	5/130
Precision version		1317451	1317454	
H1 grease version		1414121	1475549	1475560
Dustproof/H1 grease version		1475793	1475827	1475828
Weight	[kg]	0.1	0.12	0.12
IP protection class		64	64	64

① It may take a few 100 gripping cycles until the full gripping force (as indicated in the data table) will be available.

Main view

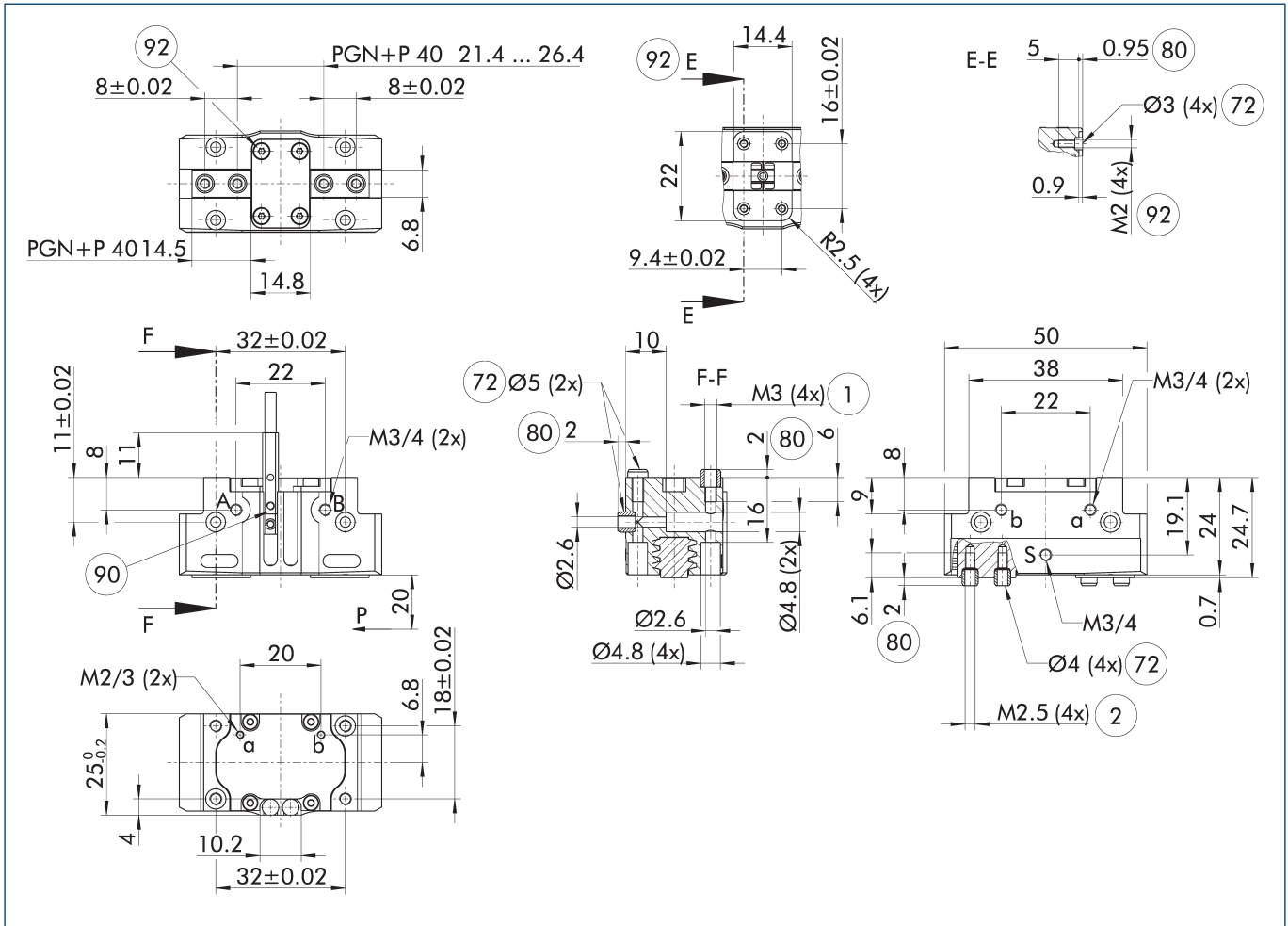

The drawing shows the gripper in the basic version with closed jaws, without dimensional consideration of the options described below.

① As an alternative/in addition to spring-assisted mechanical gripping force maintenance, the SDV-P pressure maintenance valve can be used for I.D. and O.D. gripping (see "Accessories" section of catalog).

- A, a Main / direct connection, gripper opening
- B, b Main / direct connection, gripper closing
- S Air purge connection
- ① Gripper connection
- ② Finger connection
- 72 Fit for centering sleeves

- 80 Depth of the centering sleeve hole in the counter part
- 90 Sensor MMS 22..
- 92 Screw connection with centering for customized mounting (these centering sleeves are not included in the scope of delivery)

PGN-plus-P 40

Universal gripper

Maximum permitted finger projection

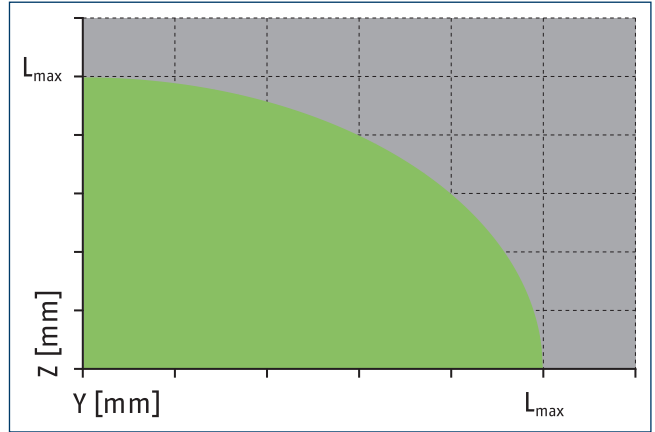
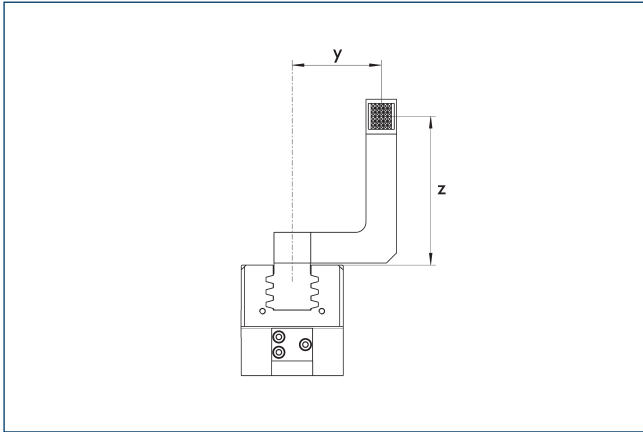

■ Permitted range ■ Inadmissible range

L_{max} is equivalent to the maximum permitted finger length, see the technical data table.

Hose-free direct connection M2

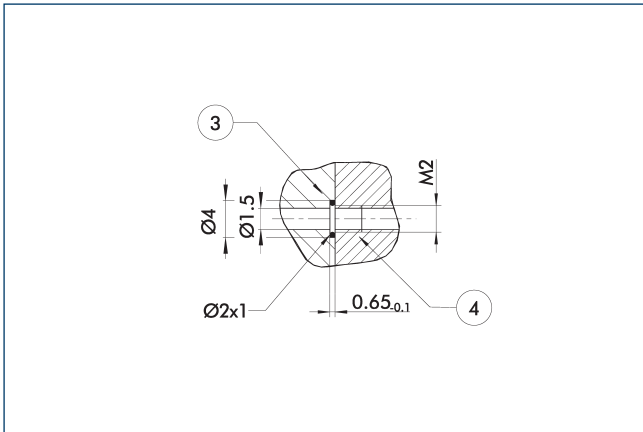

③ Adapter

④ Grippers

The direct connection is used for supplying compressed air without hoses. Instead, the pressure medium is fed through bore-holes in the mounting plate.

Gripping force maintenance version AS/IS

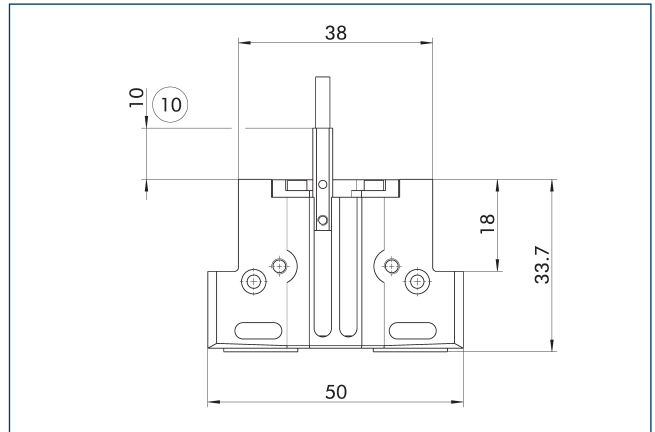

⑩ Projection applies only for AS version

The mechanical gripping force maintenance device ensures that a minimum clamping force will be applied even if there is a drop in pressure. In the AS/S variant this acts as a closing force, in the IS variant as an opening force. Besides this, gripping force maintenance can be used to increase gripping force or for single actuated gripping.

Dustproof version

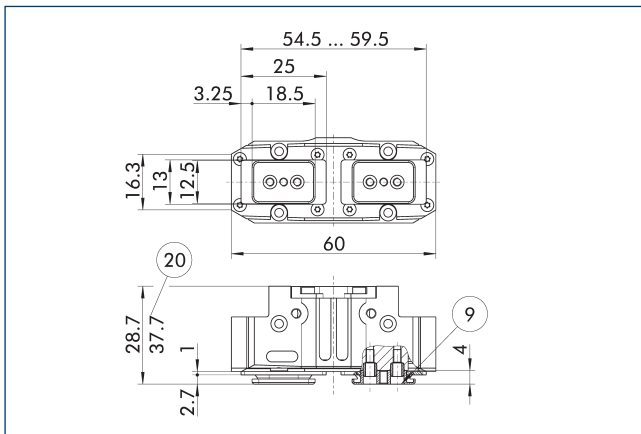

- ⑨ For mounting screw connection ⑳ For version AS/IS diagram, see basic version

The "dustproof" option increases the degree of protection against penetrating substances. The assembly diagram shifts by the height of the intermediate jaw. The finger length is still measured from the upper edge of the gripper housing.

Description	ID	
Dust cover		
SAD PGN-plus-P 40	1347469	

- ① The "dustproof" option can either be ordered as a pre-mounted gripper version or can be retrofitted to the gripper using the "SAD PGN-plus-P" retrofit kit.

SDV-P pressure maintenance valve

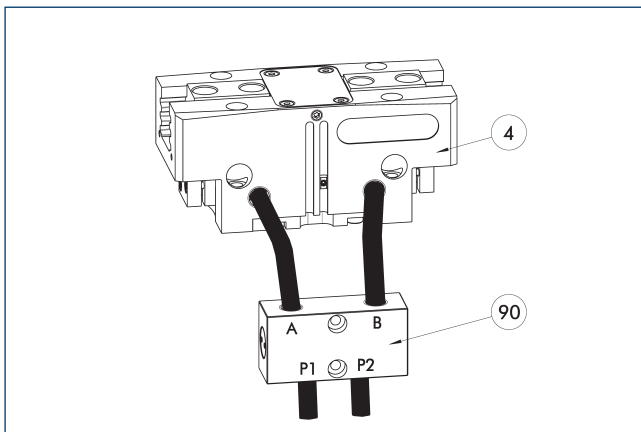

- ④ Grippers ⑨⑩ SDV-P pressure maintenance valve

The SDV-P pressure maintenance valve ensures in emergency STOP situations that the pressure in the piston chamber of pneumatic gripper, swivel, linear, and quick-change modules is temporarily maintained.

Description	ID	Recommended hose diameter
		[mm]
Pressure maintenance valve		
SDV-P 04	0403130	6
Pressure maintenance valve with air bleed screw		
SDV-P 04-E	0300120	6

- ① In order to achieve the specified closing and opening time for each gripper variant, the recommended hose diameter must be used. The direct allocation of the respective variant of the gripper for the respective SDV-P can be found at schunk.com.

Precision version

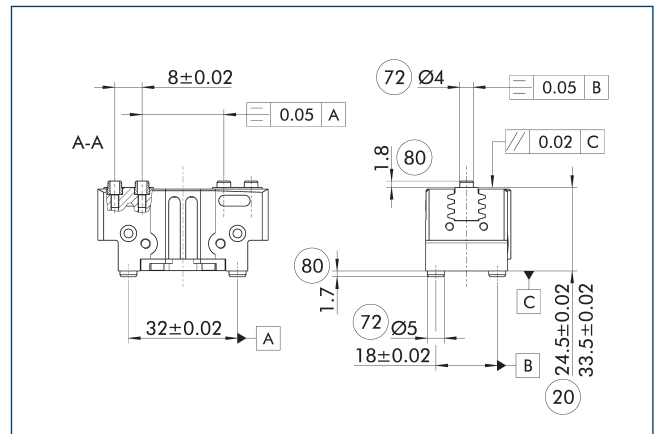

- ⑳ For version AS/IS ⑧⑩ Depth of the centering sleeve hole in the counter part
⑦⑩ Fit for centering sleeves

The indicated tolerances just refer to the variants of precision versions shown in the chart of technical specifications. All other variants of precision versions are available on request.

Protective cover HUE PGN-plus 40

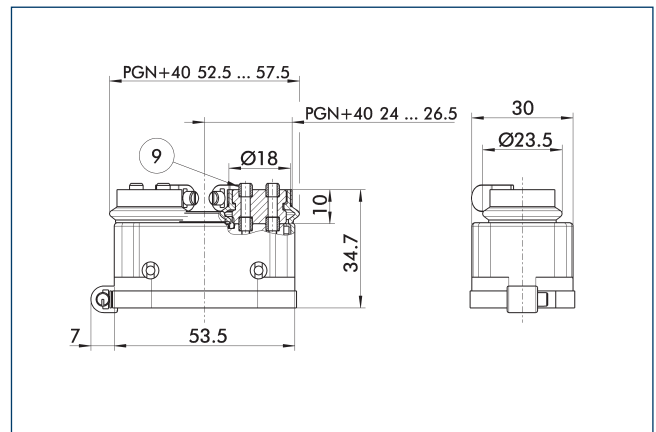

- ⑨ For mounting screw connection diagram, see basic version

The HUE protective cover fully protects the gripper against external influences. The cover is suitable for applications of up to IP65 if an additional sealing of the cover bottom is provided. For detailed information, please see the HUE series. The connection diagram shifts by the height of the intermediate jaw.

Description	ID	IP protection class
Protection cover		
HUE PGN-plus 40	0371490	65

- ① The HUE protective cover is not suitable for use on grippers with gripping force maintenance. An inductive monitoring of the gripper in connection with the HUE protective cover is not possible. SCHUNK recommends the use of magnetic sensors that are approved for the respective gripper variant.

PGN-plus-P 40

Universal gripper

UZB 40 universal intermediate jaw

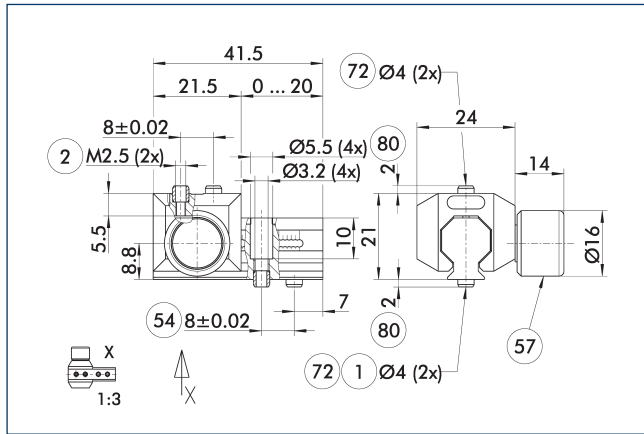

- ① Gripper connection
- ② Finger connection
- ⑤4 Optional right or left connection
- ⑤7 Locking
- ⑦2 Fit for centering sleeves
- ⑧0 Depth of the centering sleeve hole in the counter part

The drawing shows the UZB universal intermediate jaw.

Description	ID	Grid dimension
		[mm]
Universal intermediate jaw		
UZB 40	0300040	1
Finger blank		
ABR-PGZN-plus 40	0300008	
SBR-PGZN-plus 40	0300018	

- ① If the operating pressure is higher than 6 bar, suitability for use beyond the application limits must be checked.

Fields of application

Series	Size	Variant	Suitability
PGN-plus-P	40	-1 (6 bar)	■■■■
PGN-plus-P	40	-1-AS/1-IS (6 bar)	■■□□
Legend			
■■■■	Can be combined without restrictions		
■■□□	Use with restrictions (see loading limits)		
□□□□	cannot be combined		

The load limits for describing the application limits can be found in the catalog chapter of the corresponding accessories.

Finger blanks ABR/SBR-PGZN-plus 40

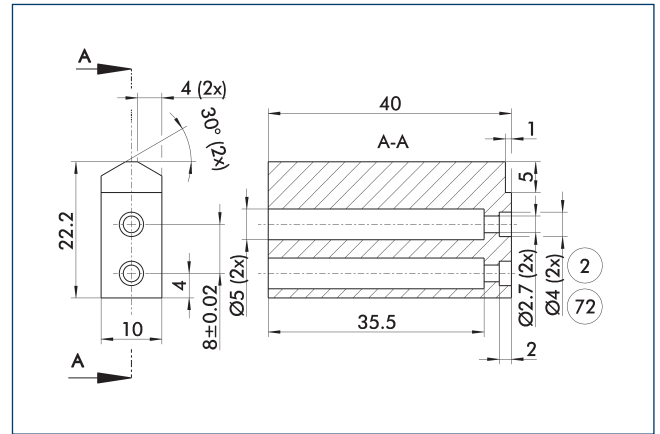

- ② Finger connection
- ⑦2 Fit for centering sleeves

The drawing shows the finger blank which can be reworked by the customer.

Description	ID	Material	Scope of delivery
Finger blank			
ABR-PGZN-plus 40	0300008	Aluminum (3.4365)	1
SBR-PGZN-plus 40	0300018	Steel (1.7131)	1

Compensation unit AGE-F

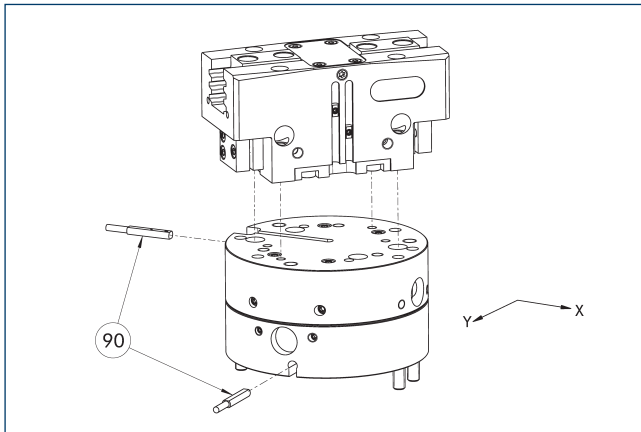

90 Monitoring

The unit has direct connection possibilities for different grippers of the PGN-plus, PGN-plus-P and PZN-plus series. For more detailed information, please refer to the main view.

Description	ID	Compensation XY	Reset force	Often combined
		[mm]	[N]	
Compensation unit				
AGE-F-XY-031-1	0324900	± 1.5	1.5	
AGE-F-XY-031-2	0324901	± 1.5	4	
AGE-F-XY-031-3	0324902	± 1.5	5.5	●

① Due to the interfering contour, monitoring of the gripper is not possible.

Adapter plate for PGN-plus 40

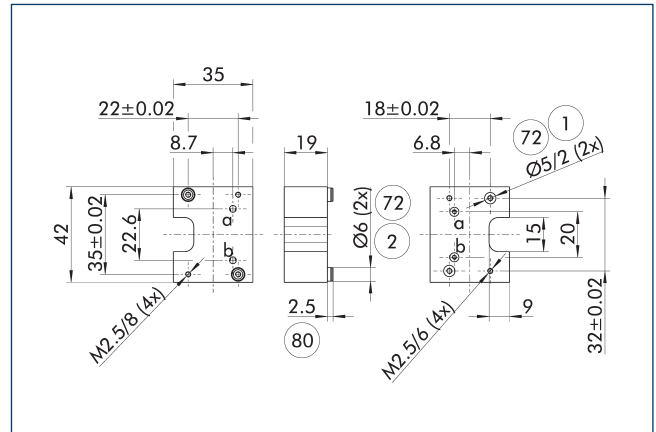

1 Robot-side connection

2 Tool-side connection

72 Fit for centering sleeves

80 Depth of the centering sleeve hole in the counter part

The adapter plate has integrated air feed-throughs in order to be able to use the hose-free direct connection of the appropriate gripper.

Description	ID
Tool side	
A-CWA-050-040-P	0305754

PGN-plus-P 40

Universal gripper

Add-on valves for single grippers

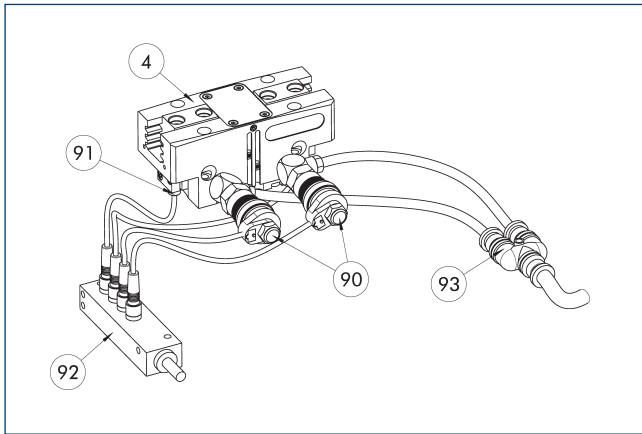

- ④ Grippers
- ⑨① Sensor
- ⑨② Sensor distributor
- ⑨③ Y distributor
- ⑨② Micro valves

The set of attachment valves reduces the compressed air consumption as there is no need to ventilate or bleed the supply lines. This can also reduce cycle time. The hose-free direct assembly of the micro valves reduces the hosing effort for the gripper. To further simplify electrical connection of the valves and sensors, their signals can be bundled via an optional distributor.

Description	ID	Often combined
Add-on valve set		
ABV-MV15-M3	0303322	
ABV-MV15-M3-V2-M8	0303384	
ABV-MV15-M3-V4-M8	0303354	●

- ① A set of add-on valves ABV is required per actuator. The ABV set contains two 3/2 micro valves, an Y-distributor for compressed air supply and optionally a sensor distributor with two or four inputs or outputs. Sensors for monitoring the gripper need to be ordered separately. Pneumatic hoses are not included in the scope of delivery.

Add-on valves for double grippers

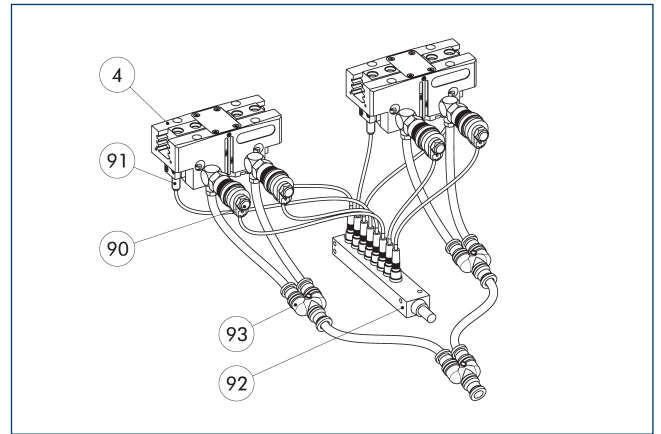

- ④ Grippers
- ⑨① Sensor
- ⑨② Sensor distributor
- ⑨③ Y distributor
- ⑨② Micro valves

The add-on valve set reduces compressed air consumption as there is no need to ventilate or bleed the supply lines. This can also reduce cycle time. The hose-free direct assembly of the micro valves reduces the hosing effort for the gripper. To further simplify electrical connection of the valves and sensors, their signals can be bundled via a distributor.

Description	ID	
Add-on valve set		
ABV-MV15-M3-V8-M8	0303355	

- ① A set of add-on valves ABV is required per double gripping unit. The ABV set contains four 3/2 microvalves, three Y-distributors for compressed air supply and a sensor distributor with eight inputs or outputs. Sensors for monitoring the gripper need to be ordered separately. Pneumatic hoses are not included in the scope of delivery.

Modular Assembly Automation

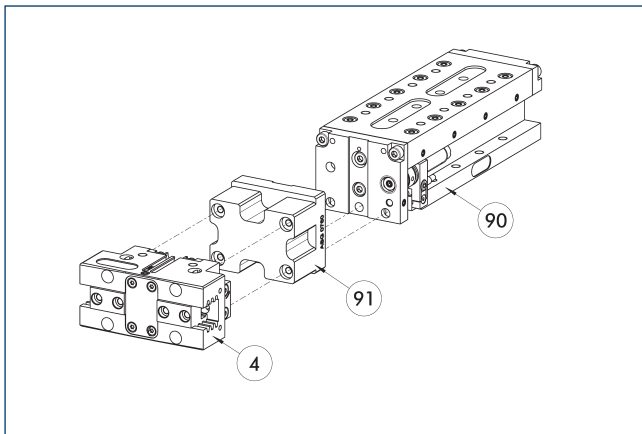

- ④ Grippers
- ⑨① ASG adapter plate
- ⑨② Linear module CLM/KLM/LM/ELP/ELM/ELS/HLM

Grippers and linear modules can be combined with standard adapter plates from the modular assembly system. For more information see our main catalog "Modular Assembly Automation".

Electronic magnetic switch MMS

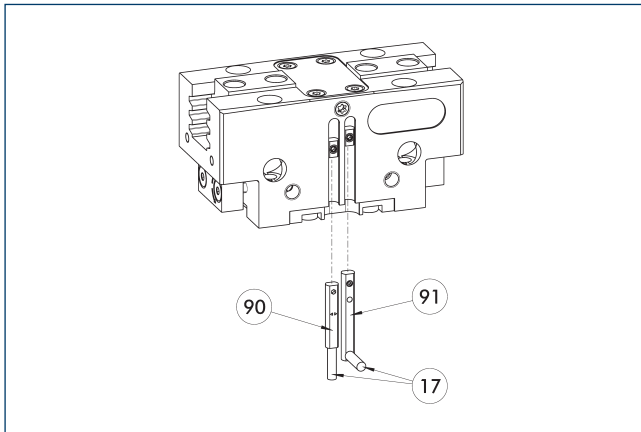

- ①⑦ Cable outlet
- ①⑨ Sensor MMS 22...-SA
- ①⑩ Sensor MMS 22..

End position monitoring for mounting in the C-slot.

Description	ID	Often combined
Electronic magnetic switch		
MMS 22-S-M8-PNP	0301032	●
MMSK 22-S-PNP	0301034	
Electronic magnetic switches with lateral cable outlet		
MMS 22-S-M8-PNP-SA	0301042	●
MMSK 22-S-PNP-SA	0301044	
Connection cables		
KA BG08-L 3P-0300-PNP	0301622	●
KA BG08-L 3P-0500-PNP	0301623	
KA BW08-L 3P-0300-PNP	0301594	
KA BW08-L 3P-0500-PNP	0301502	
Clip for connector/socket		
CLI-M8	0301463	
Cable extension		
KV BW08-SG08 3P-0030-PNP	0301495	
KV BW08-SG08 3P-0100-PNP	0301496	
KV BW08-SG08 3P-0200-PNP	0301497	●
Sensor distributor		
V2-M8	0301775	●
V4-M8	0301746	
V8-M8	0301751	

- ① Two sensors are required per unit for monitoring two positions. On option, extension cables and sensor distributors are available. Additional product variants of the sensor, and further information and technical data can be found in the catalog chapter sensor system.

Programmable magnetic switch MMS 22-PI1

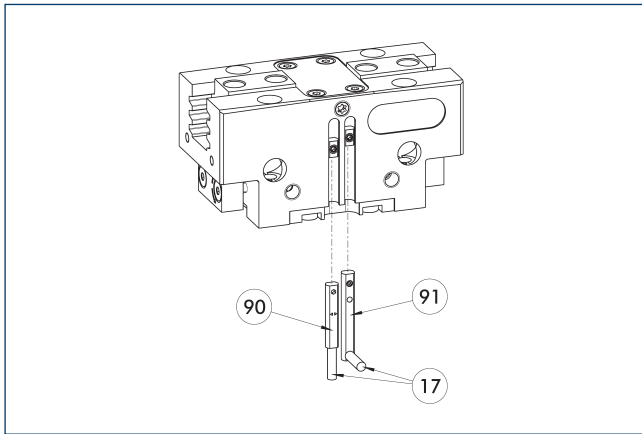

- ⑰ Cable outlet
- ⑨① Sensor MMS 22 ..-PI1-...-SA
- ⑨② Sensor MMS 22 PI1-...

Position monitoring with one programmable position per sensor and integrated electronic system in the sensor. Can be programmed using MT magnetic teaching tool (included in the scope of delivery, ID 0301030) or ST plug teaching tool (optional). End position monitoring for mounting in the C-slot. If the ST plug teaching tools are listed in the table provided, teaching is only possible with the ST teaching tools.

Description	ID	Often combined
Programmable magnetic switch		
MMS 22-PI1-S-M8-PNP	0301160	●
MMSK 22-PI1-S-PNP	0301162	
Programmable magnetic switch with lateral cable outlet		
MMS 22-PI1-S-M8-PNP-SA	0301166	●
MMSK 22-PI1-S-PNP-SA	0301168	
Programmable magnetic switch with stainless steel housing		
MMS 22-PI1-S-M8-PNP-HD	0301110	●
MMSK 22-PI1-S-PNP-HD	0301112	

- ① Two sensors are required per unit for monitoring two positions. On option, extension cables and sensor distributors are available. Additional product variants of the sensor, and further information and technical data can be found in the catalog chapter sensor system.

Programmable magnetic switch MMS 22-PI2

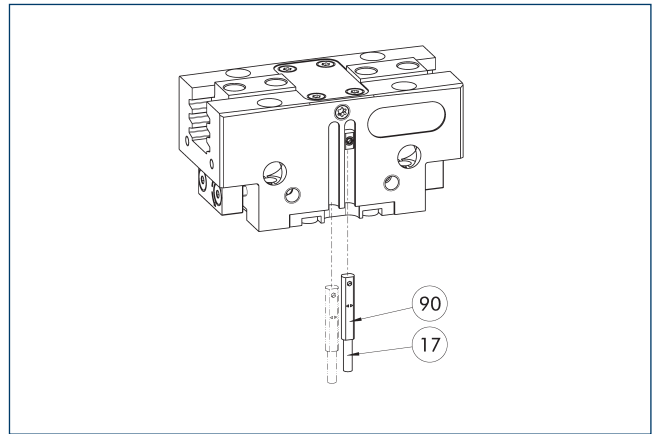

- ⑰ Cable outlet
- ⑨② MMS 22...-PI2-... sensor

Position monitoring with two programmable positions per sensor and electronics integrated in the sensor. Can be programmed using MT magnetic teaching tool (included in the scope of delivery, ID 0301030) or ST plug teaching tool (optional). End position monitoring for mounting in the C-slot. If the ST plug teaching tools are listed in the table provided, teaching is only possible with the ST teaching tools.

Description	ID	Often combined
Programmable magnetic switch		
MMS 22-PI2-S-M8-PNP	0301180	●
MMSK 22-PI2-S-PNP	0301182	
Programmable magnetic switch with lateral cable outlet		
MMS 22-PI2-S-M8-PNP-SA	0301186	●
MMSK 22-PI2-S-PNP-SA	0301188	
Programmable magnetic switch with stainless steel housing		
MMS 22-PI2-S-M8-PNP-HD	0301130	●
MMSK 22-PI2-S-PNP-HD	0301132	

- ① One sensor is required per unit for monitoring two positions. Extension cables and sensor distributors are optionally available. Additional product variants of the sensor, and further information and technical data can be found in the catalog chapter sensor systems.

MMS-P programmable magnetic switch

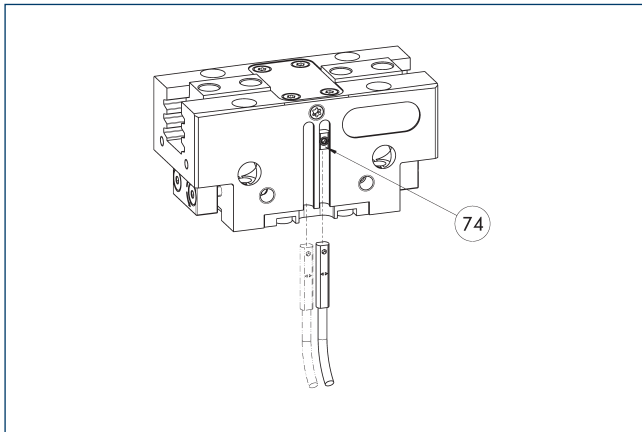

74 Limit stop for sensor

Position monitoring with two programmable positions per sensor. End position monitoring for mounting in the C-slot.

Description	ID	Often combined
Programmable magnetic switch		
MMSK-P 22-S-PNP	0301371	
MMS-P 22-S-M8-PNP	0301370	●
Connection cables		
KA GLN0804-LK-00500-A	0307767	●
KA GLN0804-LK-01000-A	0307768	
KA WLN0804-LK-00500-A	0307765	
KA WLN0804-LK-01000-A	0307766	
Clip for connector/socket		
CLI-M8	0301463	
Sensor distributor		
V2-M8-4P-2XM8-3P	0301380	

① One sensor is required per unit for monitoring two positions. Extension cables and sensor distributors are optionally available. Additional product variants of the sensor, and further information and technical data can be found in the catalog chapter sensor systems.

Analog position sensor MMS-A

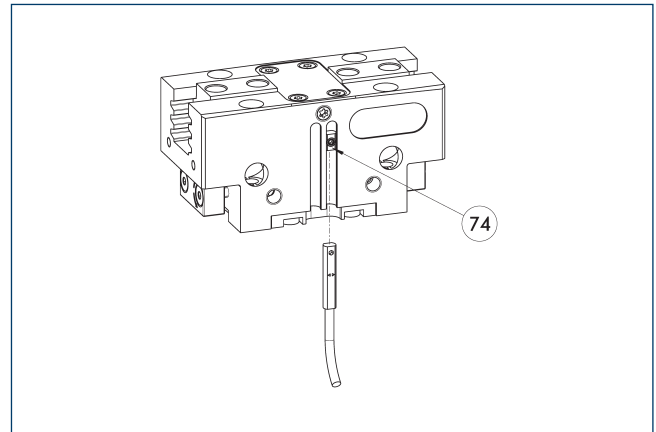

74 Limit stop for sensor

Non-contact measuring, analog multi-position monitoring for any number of positions, easy to assemble in the C-slot. Can be programmed using MT magnetic teaching tool (included in the scope of delivery, ID 0301030) or ST plug teaching tool (optional). End position monitoring for mounting in the C-slot. If the ST plug teaching tools are listed in the chart provided, teaching is only possible with the ST teaching tools.

Description	ID	
Analog position sensor		
MMS 22-A-10V-M08	0315825	
MMS 22-A-10V-M12	0315828	

① One sensor is required for each gripper. No additional mounting kit is required – the gripper is equipped for use of the sensor by default. Further information and technical data can be found in the catalog chapter sensor systems.

PGN-plus-P 40

Universal gripper

Flexible position sensor with MMS-A

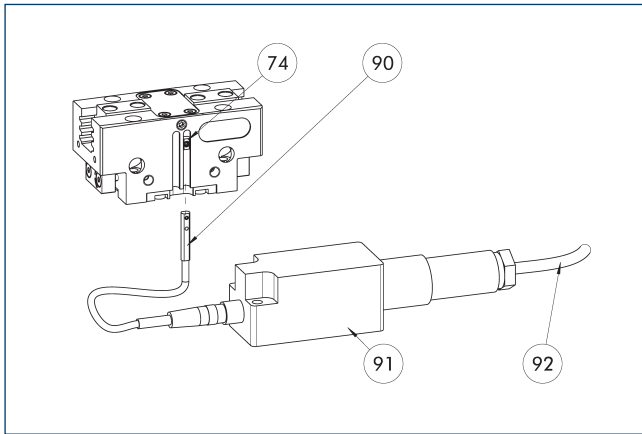

- ⑦④ Limit stop for sensor
- ⑨① FPS-F5 evaluation electronic
- ⑨① MMS 22-A-... sensor
- ⑨② Connection cables

Flexible position monitoring of up to five positions. Sensor can be taught using MT magnetic teaching tool (included in the scope of delivery, ID 0301030) or ST plug teaching tool (optional). If the ST plug teaching tools are listed in the table provided, teaching is only possible with the ST teaching tools.

Description	ID	
Analog position sensor		
MMS 22-A-05V-M08	0315805	
Evaluation electronics		
FPS-F5	0301805	
Sensor Teaching Tool		
MT-MMS 22-PI	0301030	
Connection cables		
KA BG16-L 12P-1000	0301801	

- ① When using an FPS system, one MMS 22-A-05V and one evaluation electronics (FPS-F5) are required per each gripper, as well as an attachment kit (AS), if listed. On option, cable extensions (KV) are available – see catalog chapter “Accessories.”

Programmable magnetic switch MMS-IO-Link

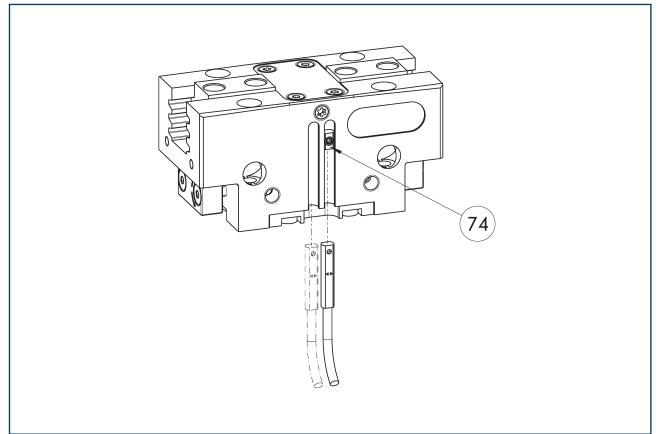

- ⑦④ Limit stop for sensor

Sensor for multi-position monitoring through detection of the complete gripper stroke. The sensor is mounted directly in the C-slot of the gripper. The sensor is programmed for the gripper via the IO-Link interface, Magnet teaching tool MT (included in scope of delivery; ID 0301030) or the ST plug teaching tool (not included in scope of delivery; ID 0301026). An IO-Link master is required for operation.

Description	ID	
Programmable magnetic switch		
MMS 22-IO-L-M08	0315830	
MMS 22-IO-L-M12	0315835	

- ① One sensor is required for each gripper. No additional mounting kit is required – the gripper is equipped for use of the sensor by default. Further information and technical data can be found in the catalog chapter sensor systems.

PGN-plus-P 50

Universal gripper



Gripping force O.D. gripping

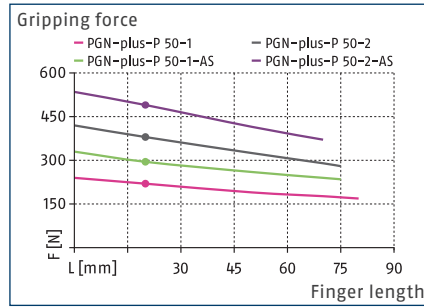

Gripping force I.D. gripping

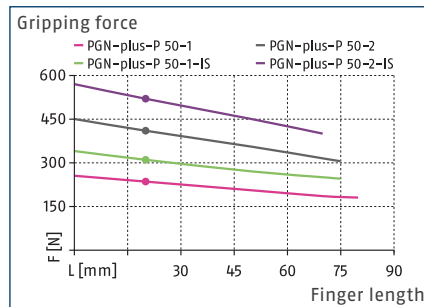

Dimensions and maximum loads

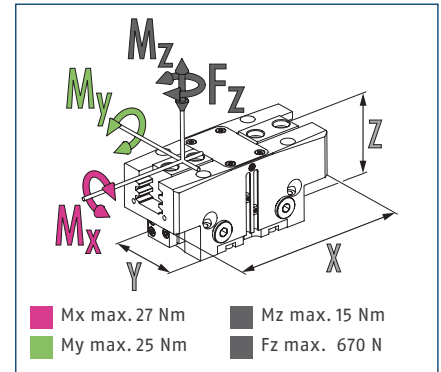

① The indicated moments and forces are static values, apply for each base jaw and may appear simultaneously. Loads may additionally occur to the moment produced by the gripping force itself.

Technical data

Description		PGN-plus-P 50-1	PGN-plus-P 50-2	PGN-plus-P 50-1-AS	PGN-plus-P 50-2-AS	PGN-plus-P 50-1-IS	PGN-plus-P 50-2-IS
ID		0318472	0318473	0318474	0318475	0318476	0318477
Stroke per jaw	[mm]	4	2	4	2	4	2
Closing/opening force	[N]	220/235	380/410	295/-	490/-	-/300	-/520
Min. spring force	[N]			75	110	65	110
Weight	[kg]	0.17	0.17	0.2	0.2	0.2	0.2
Recommended workpiece weight	[kg]	1.1	1.9	1.1	1.9	1.1	1.9
Fluid consumption double stroke	[cm ³]	6	6	10	10	12	12
Min./nom./max. operating pressure	[bar]	2.5/6/8	2.5/6/8	4/6/6.5	4/6/6.5	4/6/6.5	4/6/6.5
Min./max. air purge pressure	[bar]	0.5/1	0.5/1	0.5/1	0.5/1	0.5/1	0.5/1
Closing/opening time	[s]	0.015/0.015	0.015/0.015	0.015/0.025	0.015/0.025	0.025/0.015	0.025/0.015
Closing/opening time with spring	[s]			0.03	0.03	0.03	0.03
Max. permissible finger length	[mm]	80	75	75	70	75	70
Max. permissible weight per finger	[kg]	0.2	0.2	0.2	0.2	0.2	0.2
IP protection class		40	40	40	40	40	40
Min./max. ambient temperature	[°C]	5/90	5/90	5/90	5/90	5/90	5/90
Repeat accuracy	[mm]	0.01	0.01	0.01	0.01	0.01	0.01
Dimensions X x Y x Z	[mm]	65 x 30 x 31	65 x 30 x 31	65 x 30 x 47	65 x 30 x 47	65 x 30 x 47	65 x 30 x 47
Options and their characteristics							
Dustproof version		1317516	1317527	1317531	1317534	1317539	1317541
IP protection class		64	64	64	64	64	64
Weight	[kg]	0.21	0.21	0.24	0.24	0.24	0.24
Corrosion-protected version		38318472	38318473	38318474	38318475	38318476	38318477
High-temperature version		39318472	39318473	39318474	39318475	39318476	39318477
Min./max. ambient temperature	[°C]	5/130	5/130	5/130	5/130	5/130	5/130
Precision version		0318478	0318479	0318480	0318481		
H1 grease version		1328472	1475830	1353810	1475833	1353811	1475836
Dustproof/H1 grease version		1475829	1475831	1475832	1475834	1475835	1475837
Weight	[kg]	0.21	0.21	0.24	0.24	0.24	0.24
IP protection class		64	64	64	64	64	64

① It may take a few 100 gripping cycles until the full gripping force (as indicated in the data table) will be available.

Main view

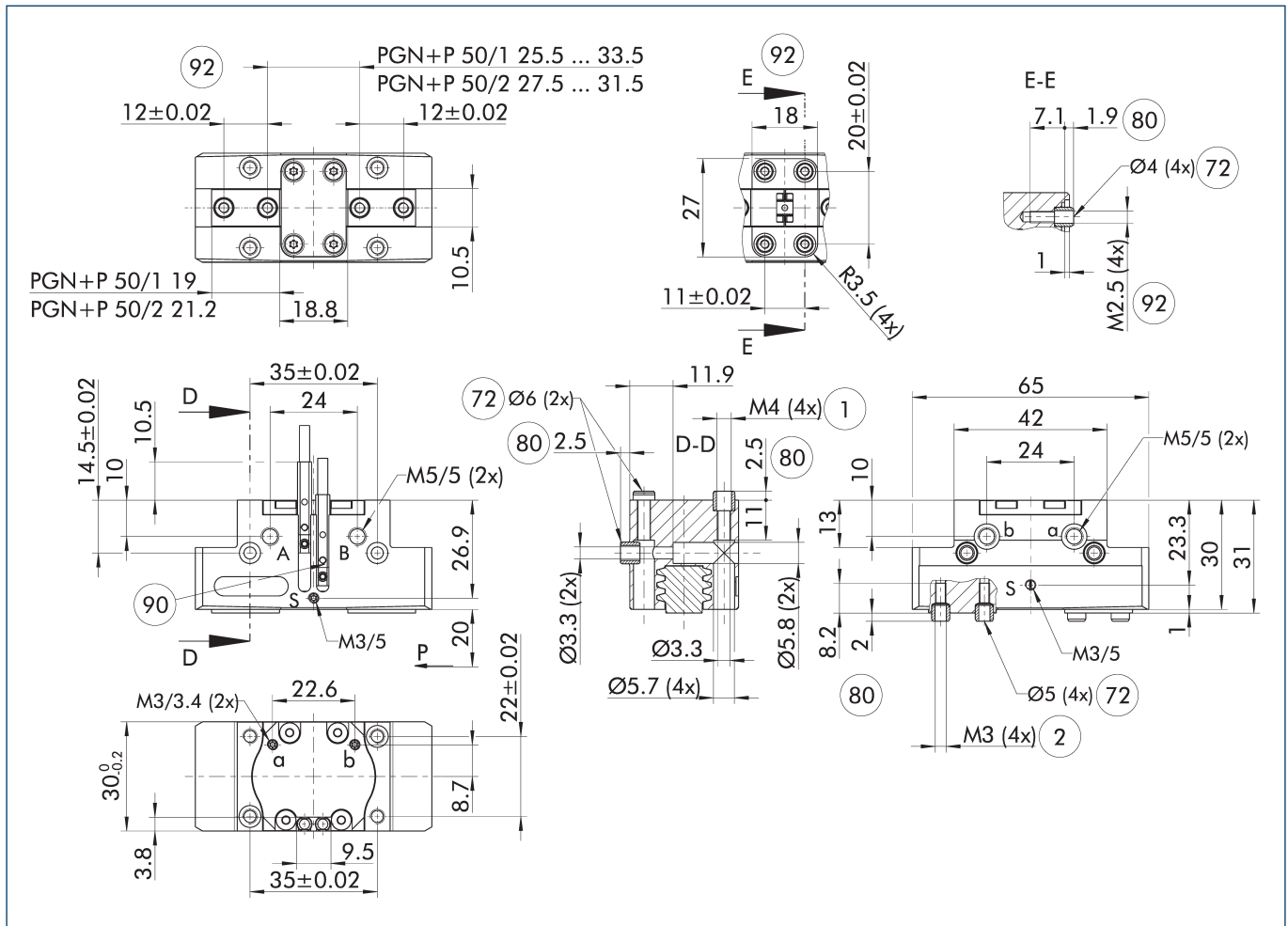

The drawing shows the gripper in the basic version with closed jaws, without dimensional consideration of the options described below.

① As an alternative/in addition to spring-assisted mechanical gripping force maintenance, the SDV-P pressure maintenance valve can be used for I.D. and O.D. gripping (see "Accessories" section of catalog).

- A, a Main / direct connection, gripper opening
- B, b Main / direct connection, gripper closing
- S Air purge connection
- ① Gripper connection
- ② Finger connection
- ⑦ Fit for centering sleeves

- ⑧ Depth of the centering sleeve hole in the counter part
- ⑨ Sensor MMS 22..
- ⑩ Screw connection with centering for customized mounting (these centering sleeves are not included in the scope of delivery)

PGN-plus-P 50

Universal gripper

Maximum permitted finger projection

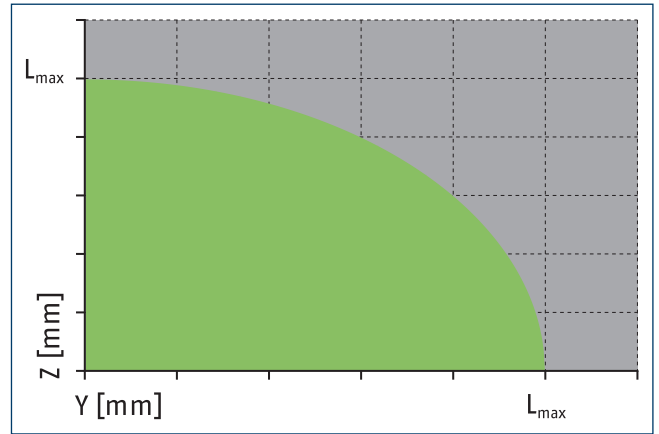
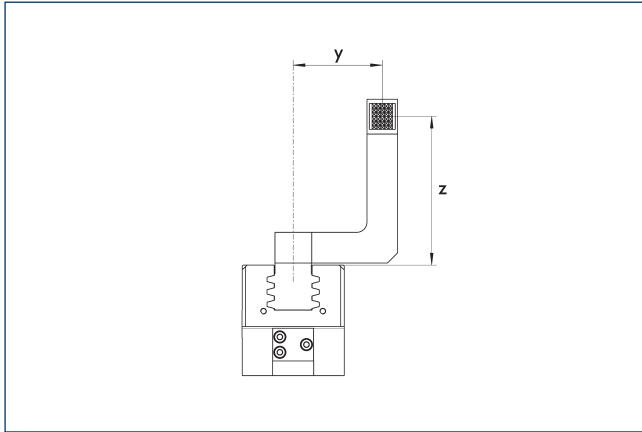

■ Permitted range

■ Inadmissible range

L_{max} is equivalent to the maximum permitted finger length, see the technical data table.

Hose-free direct connection M3

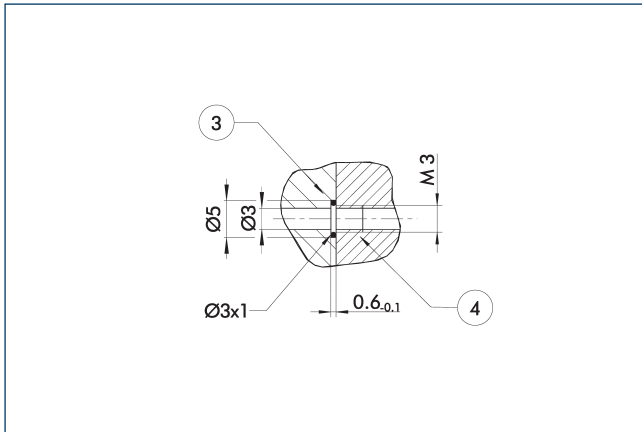

③ Adapter

④ Grippers

The direct connection is used for supplying compressed air without hoses. Instead, the pressure medium is fed through bore-holes in the mounting plate.

Gripping force maintenance version AS/IS

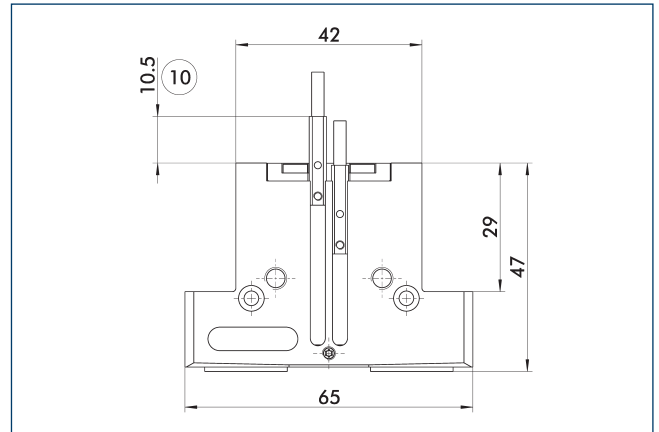

⑩ Projection applies only for AS version

The mechanical gripping force maintenance device ensures that a minimum clamping force will be applied even if there is a drop in pressure. In the AS/S variant this acts as a closing force, in the IS variant as an opening force. Besides this, gripping force maintenance can be used to increase gripping force or for single actuated gripping.

Dustproof version

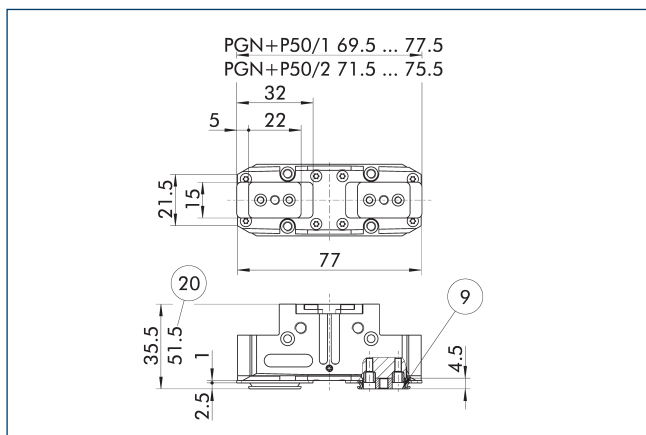

- ⑨ For mounting screw connection
- ⑳ For version AS/IS diagram, see basic version

The "dustproof" option increases the degree of protection against penetrating substances. The assembly diagram shifts by the height of the intermediate jaw. The finger length is still measured from the upper edge of the gripper housing.

Description	ID
Dust cover	
SAD PGN-plus-P 50	1347474

- ① The "dustproof" option can either be ordered as a pre-mounted gripper version or can be retrofitted to the gripper using the "SAD PGN-plus-P" retrofit kit.

Precision version

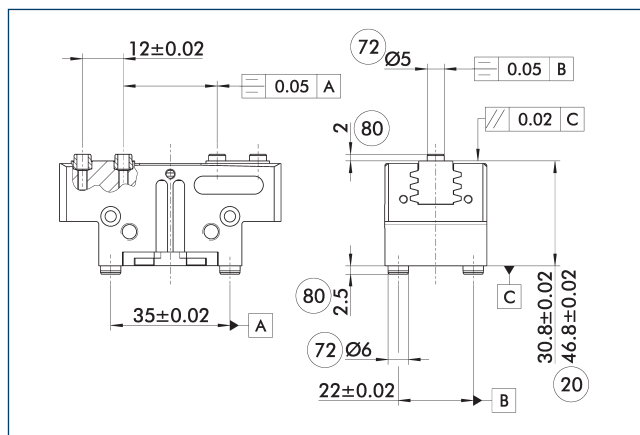

- ⑳ For version AS/IS
- ㉓ Fit for centering sleeves
- ⑧① Depth of the centering sleeve hole in the counter part

The indicated tolerances just refer to the variants of precision versions shown in the chart of technical specifications. All other variants of precision versions are available on request.

SDV-P pressure maintenance valve

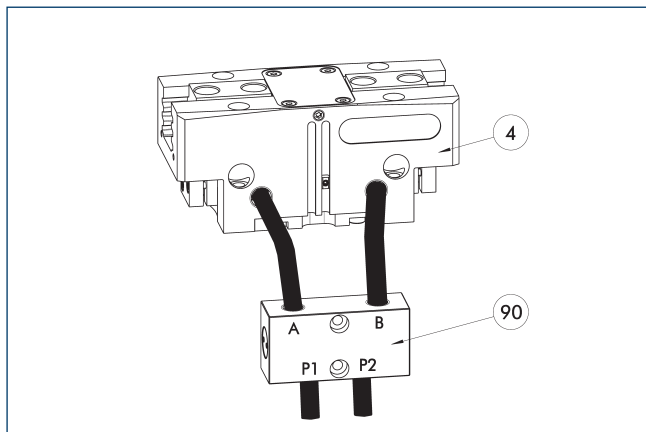

- ④ Grippers
- ⑨① SDV-P pressure maintenance valve

The SDV-P pressure maintenance valve ensures in emergency STOP situations that the pressure in the piston chamber of pneumatic gripper, swivel, linear, and quick-change modules is temporarily maintained.

Description	ID	Recommended hose diameter [mm]
Pressure maintenance valve		
SDV-P 04	0403130	6
Pressure maintenance valve with air bleed screw		
SDV-P 04-E	0300120	6

- ① In order to achieve the specified closing and opening time for each gripper variant, the recommended hose diameter must be used. The direct allocation of the respective variant of the gripper for the respective SDV-P can be found at schunk.com.

PGN-plus-P 50

Universal gripper

Pneumatic positioning device PPD

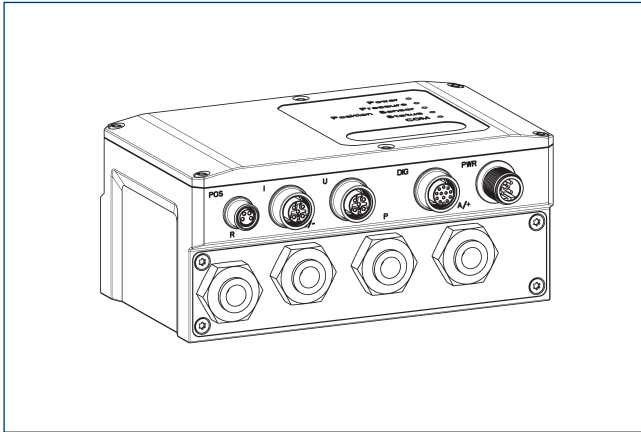

The PPD allows flexibility in all applications with pneumatic grippers through free positioning, gripping force and speed adjustment.

Description	ID	
Pneumatic positioning device		
PPD 10-IOL	1540698	
Adapter		
A GGN0804-1204-A	1540691	
IO-Link connection cable		
KA GGN1205-1212-IOL-00100-A	1540697	
Voltage supply connection cable - cable track compatible		
KA GLN12B05-LK-01000-A	1540660	
Cable extension		
KV GGN0804-I0-00150-A	1540662	
KV GGN0804-I0-00300-A	1540663	
Assembly set		
Assembly set PPD	1540705	

① In addition to the PPD, a position sensor (SCHUNK IO-Link sensor or analog sensor (4...20 mA)) is required.

Protective cover HUE PGN-plus 50

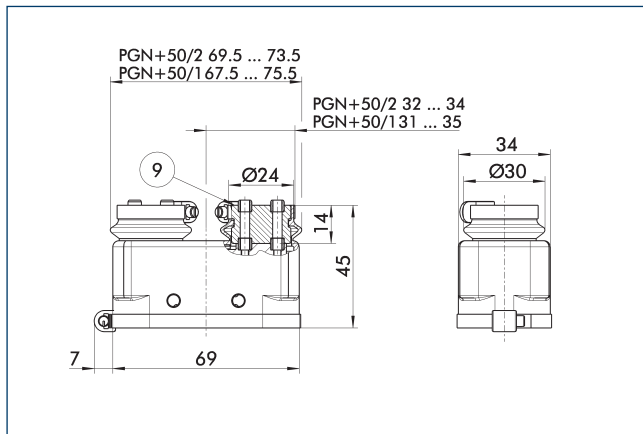

⑨ For mounting screw connection diagram, see basic version

The HUE protective cover fully protects the gripper against external influences. The cover is suitable for applications of up to IP65 if an additional sealing of the cover bottom is provided. For detailed information, please see the HUE series. The connection diagram shifts by the height of the intermediate jaw.

Description	ID	IP protection class
Protection cover		
HUE PGN-plus 50	0371479	65

① The HUE protective cover is not suitable for use on grippers with gripping force maintenance. An inductive monitoring of the gripper in connection with the HUE protective cover is not possible. SCHUNK recommends the use of magnetic sensors that are approved for the respective gripper variant.

BSWS jaw quick-change jaw systems

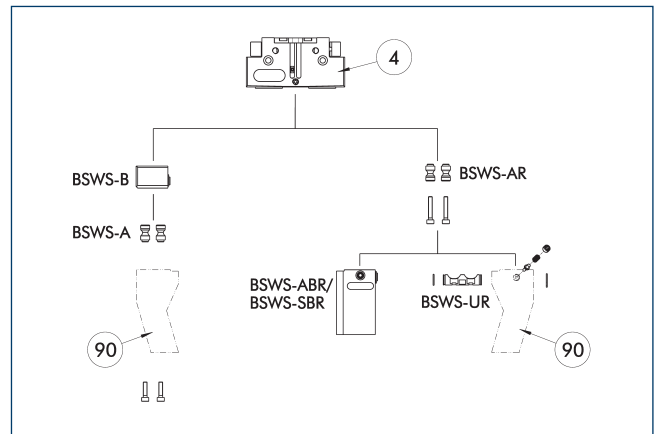

④ Grippers

⑨ Customized gripper fingers

There are various jaw quick-change systems available for the gripper. For detailed information, please refer to the corresponding product.

Description	ID	Scope of delivery
Jaw quick-change system adapter pin		
BSWS-A 50	0303020	2
BSWS-AR 50	0300091	2
Quick-change jaw system base		
BSWS-B 50	0303021	1
Jaw quick-change system finger blank		
BSWS-ABR-PGZN-plus 50	0300071	1
BSWS-SBR-PGZN-plus 50	0300081	1
Jaw quick-change system locking mechanism		
BSWS-UR 50	0302990	1

① If the operating pressure is higher than 6 bar, suitability for use beyond the application limits must be checked. Only systems that are listed in the table, can be used.

Fields of application

Series	Size	Variant	Suitability
PGN-plus-P	50	-1 (6 bar)	■■■■■
PGN-plus-P	50	-1-AS/1-IS (6 bar)	■■■■■
PGN-plus-P	50	-2 (6 bar)	■■■■■
PGN-plus-P	50	-2-AS/2-IS (6 bar)	■■■■■
Legend			
■■■■■	Can be combined without restrictions		
■■□□	Use with restrictions (see loading limits)		
□□□□	cannot be combined		

The load limits for describing the application limits can be found in the catalog chapter of the corresponding accessories.

PGN-plus-P 50

Universal gripper

Jaw quick-change system BSWs-M

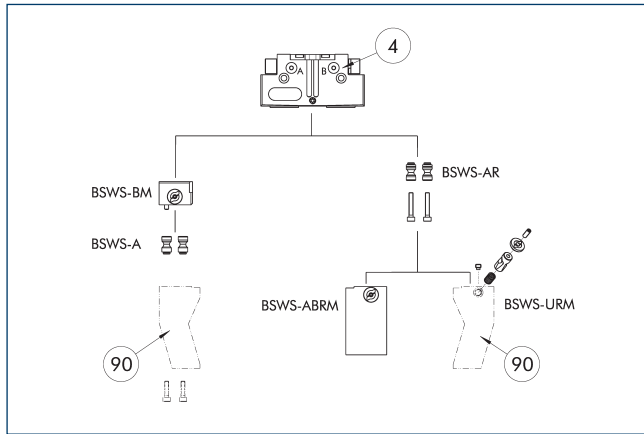

- ④ Grippers
- ⑨⑩ Customized gripper fingers

There are various jaw quick-change systems available for the gripper. For detailed information, please refer to the corresponding product.

Description	ID	Scope of delivery
Jaw quick-change system adapter pin		
BSWS-A 50	0303020	2
BSWS-AR 50	0300091	2
Quick-change jaw system base		
BSWS-BM 50	1313899	1
Jaw quick-change system finger blank		
BSWS-ABRM-PGZN-plus 50	1420850	1
Jaw quick-change system locking mechanism		
BSWS-URM 50	1380614	1

① If the operating pressure is higher than 6 bar, suitability for use beyond the application limits must be checked. Only systems that are listed in the table, can be used.

Fields of application

Series	Size	Variant	Suitability
PGN-plus-P	50	-1 (6 bar)	■■■■■
PGN-plus-P	50	-1-AS/1-IS (6 bar)	■■■■■
PGN-plus-P	50	-2 (6 bar)	■■■■■
PGN-plus-P	50	-2-AS/2-IS (6 bar)	■■■■■
Legend			
■■■■■	Can be combined without restrictions		
■■■□□	Use with restrictions (see loading limits)		
□□□□□	cannot be combined		

The load limits for describing the application limits can be found in the catalog chapter of the corresponding accessories.

ZBA-L-plus 50 intermediate jaws

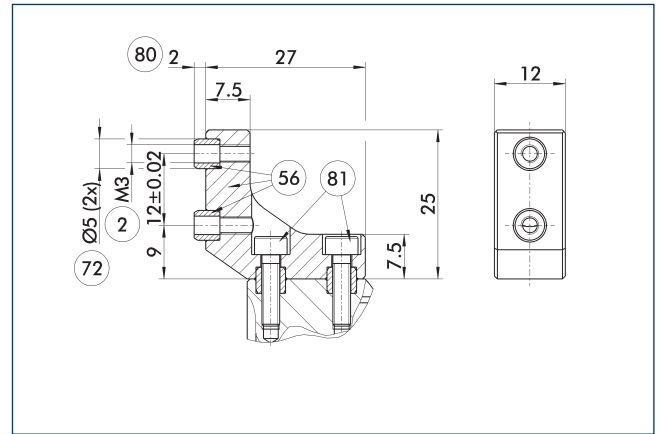

- ② Finger connection
- ⑤⑥ Included in the scope of delivery
- ⑦② Fit for centering sleeves
- ⑧⑩ Depth of the centering sleeve hole in the counter part
- ⑧① Not included in the scope of delivery

The optional ZBA-L-plus intermediate jaws allow the screw connection diagram of the top jaws to be rotated by 90°. This makes it easier to design and produce top jaws (particularly for long versions) because no deep through-bores are required.

Description	ID	Material	Finger interface	Scope of delivery
Intermediate jaw				
ZBA-L-plus 50	0311712	Aluminum	PGN-plus 50	1

UZB 50 universal intermediate jaw

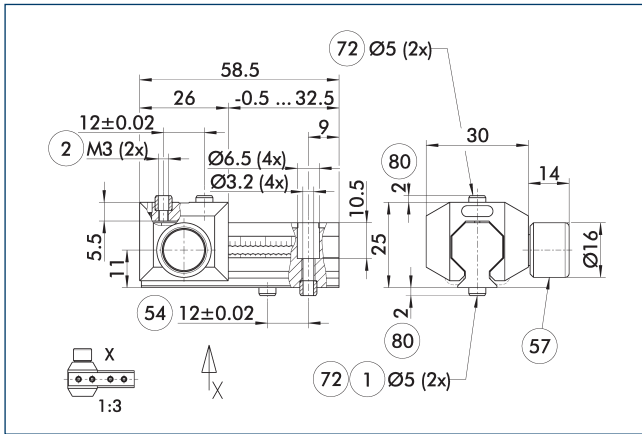

- ① Gripper connection
- ② Finger connection
- ⑤4 Optional right or left connection
- ⑤7 Locking
- ⑦2 Fit for centering sleeves
- ⑧0 Depth of the centering sleeve hole in the counter part

The drawing shows the UZB universal intermediate jaw.

Description	ID	Grid dimension
		[mm]
Universal intermediate jaw		
UZB 50	0300041	1.5
Finger blank		
ABR-PGZN-plus 50	0300009	
SBR-PGZN-plus 50	0300019	

① If the operating pressure is higher than 6 bar, suitability for use beyond the application limits must be checked.

Fields of application

Series	Size	Variant	Suitability
PGN-plus-P	50	-1 (6 bar)	■■■■
PGN-plus-P	50	-1-AS/1-IS (6 bar)	■■□□
PGN-plus-P	50	-2 (6 bar)	■■□□
PGN-plus-P	50	-2-AS/2-IS (6 bar)	□□□□
Legend			
■■■■	Can be combined without restrictions		
■■□□	Use with restrictions (see loading limits)		
□□□□	cannot be combined		

The load limits for describing the application limits can be found in the catalog chapter of the corresponding accessories.

Finger blanks ABR/SBR-PGZN-plus 50

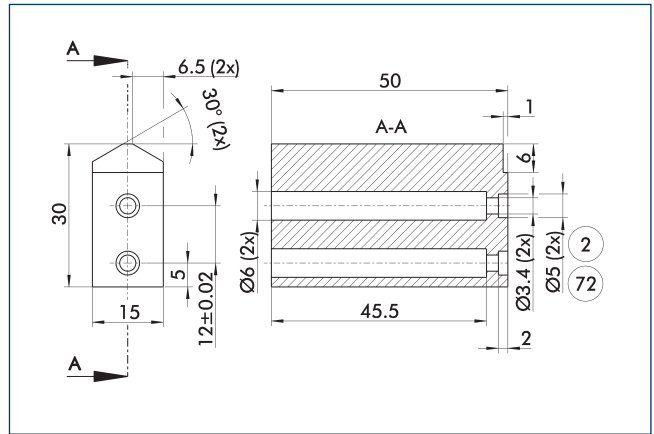

- ② Finger connection
- ⑦2 Fit for centering sleeves

The drawing shows the finger blank which can be reworked by the customer.

Description	ID	Material	Scope of delivery
Finger blank			
ABR-PGZN-plus 50	0300009	Aluminum (3.4365)	1
SBR-PGZN-plus 50	0300019	Steel (1.7131)	1

PGN-plus-P 50

Universal gripper

Tolerance compensation unit TCU

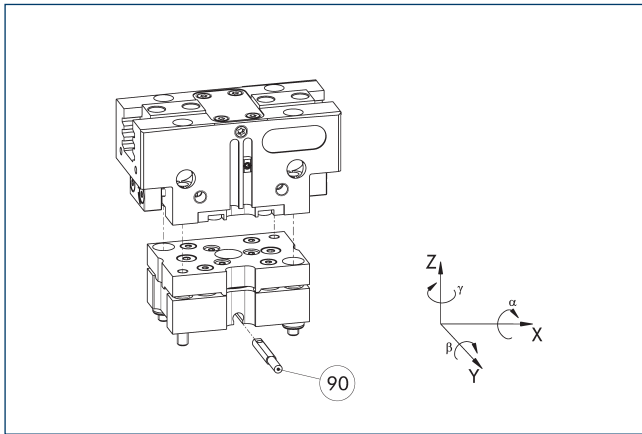

90 Monitoring of locking

Grippers can be directly mounted without an adapter plate. Tolerance compensation unit and gripper have an identical screw connection diagram. Therefore the tolerance compensation units can be assembled later. Please consider the additional assembly height of the tolerance compensation unit. For details please refer to our catalog robot accessories.

Description	ID	Locking	Deflection
Compensation unit			
TCU-P-050-3-0V	0324757	no	$\pm 1^\circ / \pm 1^\circ / \pm 1,5^\circ$

Compensation unit AGE-F

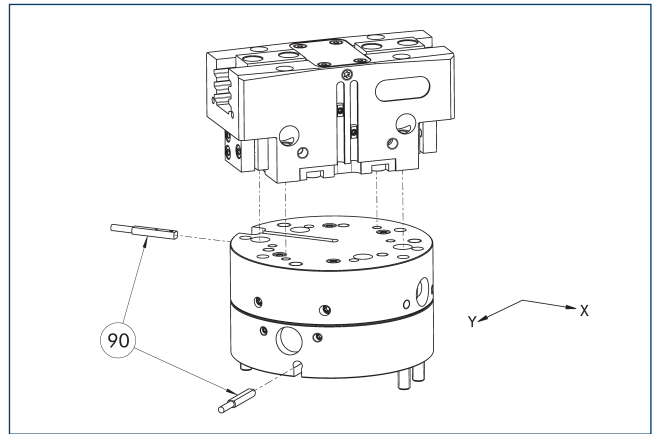

90 Monitoring

The unit has direct connection possibilities for different grippers of the PGN-plus, PGN-plus-P and PZN-plus series. For more detailed information, please refer to the main view.

Description	ID	Compensation XY [mm]	Reset force [N]	Often combined
Compensation unit				
AGE-F-XY-040-1	0324920	± 2	3	
AGE-F-XY-040-2	0324921	± 2	4	
AGE-F-XY-040-3	0324922	± 2	4.5	●

① Due to the interfering contour, monitoring of the gripper is not possible.

Adapter plate for PGN-plus 50

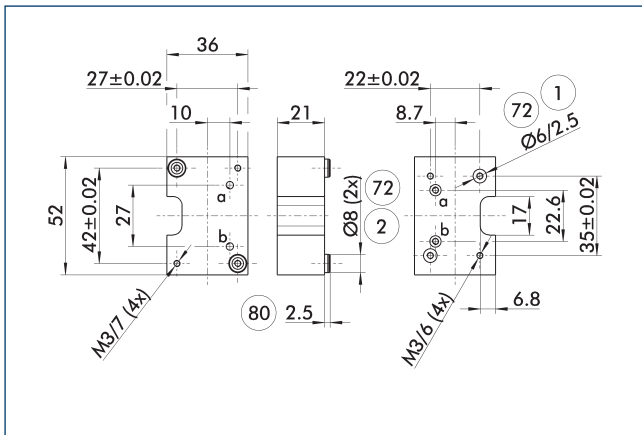

- ① Robot-side connection
- ② Tool-side connection
- 72 Fit for centering sleeves
- 80 Depth of the centering sleeve hole in the counter part

The adapter plate has integrated air feed-throughs in order to be able to use the hose-free direct connection of the appropriate gripper.

Description	ID
Tool side	
A-CWA-064-050-P	0305768

Compact change system for grippers

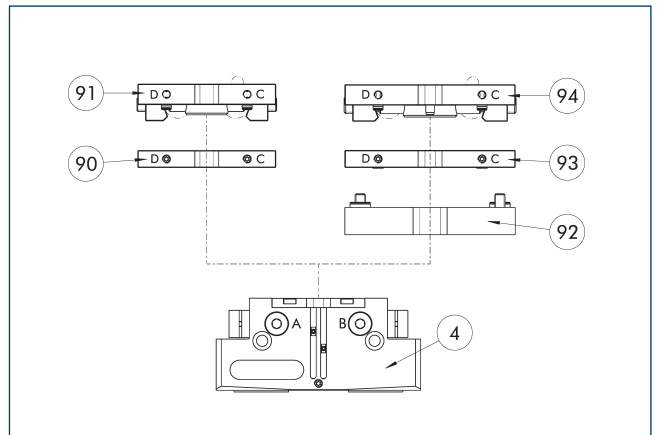

- ④ Grippers
- 90 CWA compact change adapter
- 91 CWK compact change master
- 92 A-CWA adapter plate
- 93 CWA compact change adapter
- 94 CWK compact change master

Grippers can be directly mounted without an adapter plate. For details see our catalog Gripping or Robot Accessories.

Description	ID
Tool side	
A-CWA-064-050-P	0305768
CWA compact change adapter	
CWA-050-P	0305751
CWK compact change master	
CWK-050-P	0305750

Add-on valves for single grippers

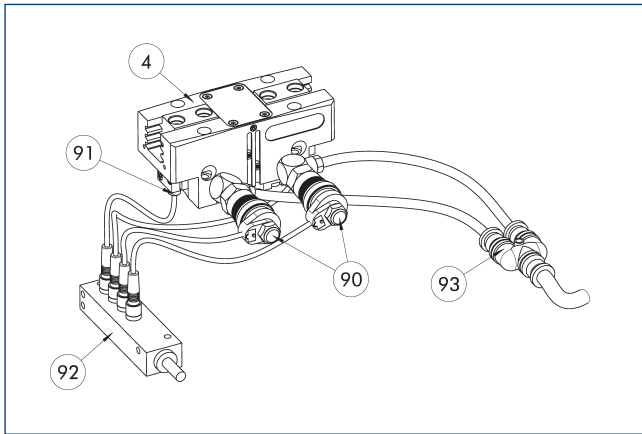

- ④ Grippers
- ⑨① Sensor
- ⑨② Sensor distributor
- ⑨③ Y distributor
- ⑨④ Micro valves

The set of attachment valves reduces the compressed air consumption as there is no need to ventilate or bleed the supply lines. This can also reduce cycle time. The hose-free direct assembly of the micro valves reduces the hosing effort for the gripper. To further simplify electrical connection of the valves and sensors, their signals can be bundled via an optional distributor.

Description	ID	Often combined
Add-on valve set		
ABV-MV15-M5	0303323	
ABV-MV15-M5-V2-M8	0303386	
ABV-MV15-M5-V4-M8	0303356	●

- ① A set of add-on valves ABV is required per actuator. The ABV set contains two 3/2 micro valves, an Y-distributor for compressed air supply and optionally a sensor distributor with two or four inputs or outputs. Sensors for monitoring the gripper need to be ordered separately. Pneumatic hoses are not included in the scope of delivery.

Add-on valves for double grippers

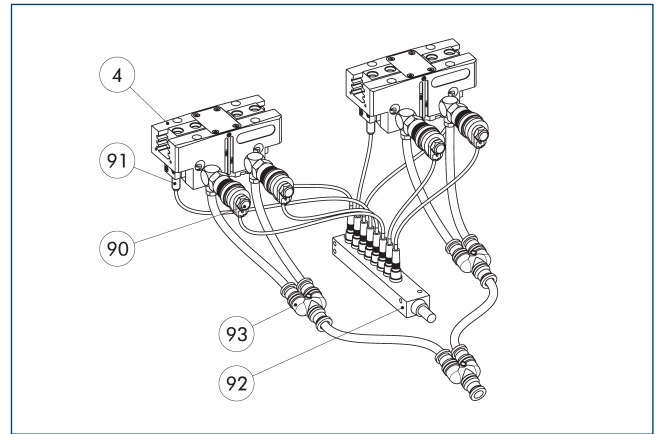

- ④ Grippers
- ⑨① Sensor
- ⑨② Sensor distributor
- ⑨③ Y distributor
- ⑨④ Micro valves

The add-on valve set reduces compressed air consumption as there is no need to ventilate or bleed the supply lines. This can also reduce cycle time. The hose-free direct assembly of the micro valves reduces the hosing effort for the gripper. To further simplify electrical connection of the valves and sensors, their signals can be bundled via a distributor.

Description	ID	
Add-on valve set		
ABV-MV15-M5-V8-M8	0303357	

- ① A set of add-on valves ABV is required per double gripping unit. The ABV set contains four 3/2 microvalves, three Y-distributors for compressed air supply and a sensor distributor with eight inputs or outputs. Sensors for monitoring the gripper need to be ordered separately. Pneumatic hoses are not included in the scope of delivery.

Modular Assembly Automation

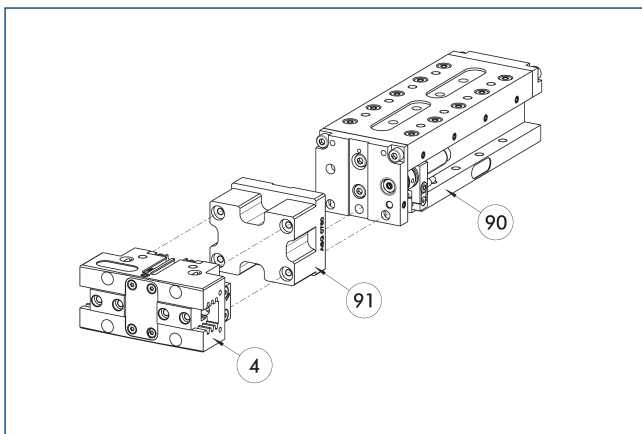

- ④ Grippers
- ⑨① ASG adapter plate
- ⑨② Linear module CLM/KLM/LM/ELP/ELM/ELS/HLM

Grippers and linear modules can be combined with standard adapter plates from the modular assembly system. For more information see our main catalog "Modular Assembly Automation".

Electronic magnetic switch MMS

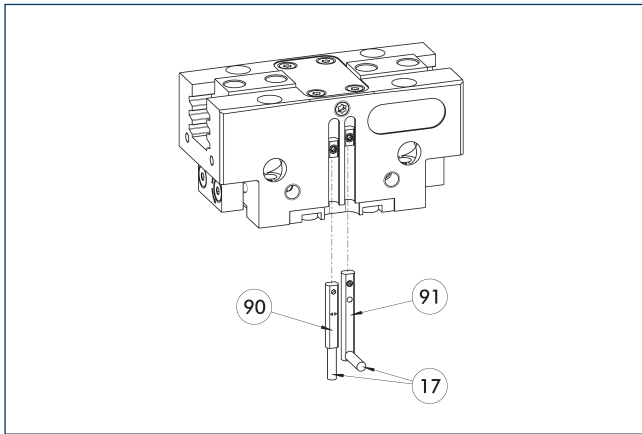

- 17 Cable outlet 91 Sensor MMS 22...-SA
90 Sensor MMS 22..

End position monitoring for mounting in the C-slot.

Description	ID	Often combined
Electronic magnetic switch		
MMS 22-S-M8-PNP	0301032	●
MMSK 22-S-PNP	0301034	
Electronic magnetic switches with lateral cable outlet		
MMS 22-S-M8-PNP-SA	0301042	●
MMSK 22-S-PNP-SA	0301044	
Connection cables		
KA BG08-L 3P-0300-PNP	0301622	●
KA BG08-L 3P-0500-PNP	0301623	
KA BW08-L 3P-0300-PNP	0301594	
KA BW08-L 3P-0500-PNP	0301502	
Clip for connector/socket		
CLI-M8	0301463	
Cable extension		
KV BW08-SG08 3P-0030-PNP	0301495	
KV BW08-SG08 3P-0100-PNP	0301496	
KV BW08-SG08 3P-0200-PNP	0301497	●
Sensor distributor		
V2-M8	0301775	●
V4-M8	0301746	
V8-M8	0301751	

- ① Two sensors are required per unit for monitoring two positions. On option, extension cables and sensor distributors are available. Additional product variants of the sensor, and further information and technical data can be found in the catalog chapter sensor system.

Programmable magnetic switch MMS 22-PI1

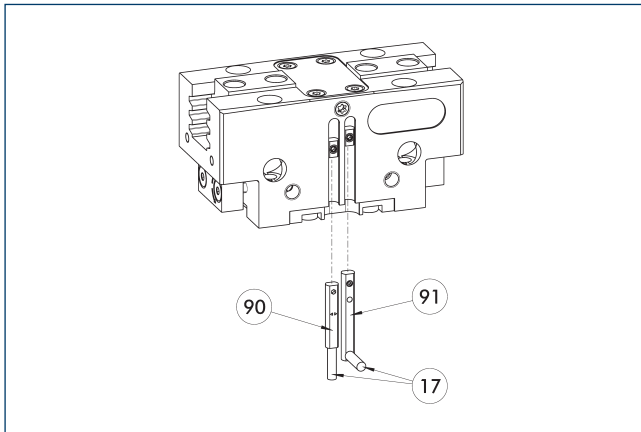

- ⑰ Cable outlet
- ⑨① Sensor MMS 22 ..-PI1-...-SA
- ⑨① Sensor MMS 22 PI1-...

Position monitoring with one programmable position per sensor and integrated electronic system in the sensor. Can be programmed using MT magnetic teaching tool (included in the scope of delivery, ID 0301030) or ST plug teaching tool (optional). End position monitoring for mounting in the C-slot. If the ST plug teaching tools are listed in the table provided, teaching is only possible with the ST teaching tools.

Description	ID	Often combined
Programmable magnetic switch		
MMS 22-PI1-S-M8-PNP	0301160	●
MMSK 22-PI1-S-PNP	0301162	
Programmable magnetic switch with lateral cable outlet		
MMS 22-PI1-S-M8-PNP-SA	0301166	●
MMSK 22-PI1-S-PNP-SA	0301168	
Programmable magnetic switch with stainless steel housing		
MMS 22-PI1-S-M8-PNP-HD	0301110	●
MMSK 22-PI1-S-PNP-HD	0301112	

- ① Two sensors are required per unit for monitoring two positions. On option, extension cables and sensor distributors are available. Additional product variants of the sensor, and further information and technical data can be found in the catalog chapter sensor system.

Programmable magnetic switch MMS 22-PI2

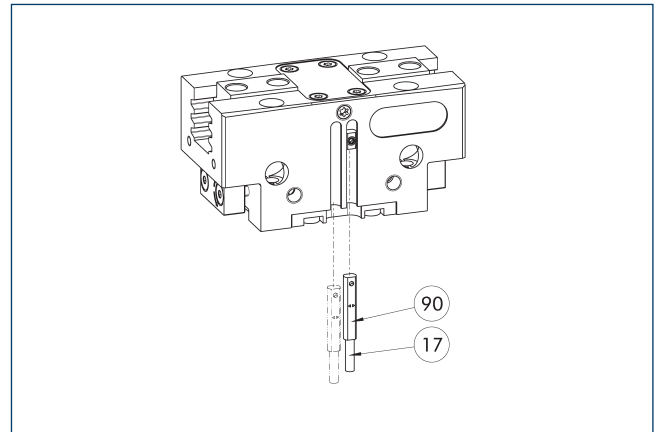

- ⑰ Cable outlet
- ⑨① MMS 22...-PI2-... sensor

Position monitoring with two programmable positions per sensor and electronics integrated in the sensor. Can be programmed using MT magnetic teaching tool (included in the scope of delivery, ID 0301030) or ST plug teaching tool (optional). End position monitoring for mounting in the C-slot. If the ST plug teaching tools are listed in the table provided, teaching is only possible with the ST teaching tools.

Description	ID	Often combined
Programmable magnetic switch		
MMS 22-PI2-S-M8-PNP	0301180	●
MMSK 22-PI2-S-PNP	0301182	
Programmable magnetic switch with lateral cable outlet		
MMS 22-PI2-S-M8-PNP-SA	0301186	●
MMSK 22-PI2-S-PNP-SA	0301188	
Programmable magnetic switch with stainless steel housing		
MMS 22-PI2-S-M8-PNP-HD	0301130	●
MMSK 22-PI2-S-PNP-HD	0301132	

- ① One sensor is required per unit for monitoring two positions. Extension cables and sensor distributors are optionally available. Additional product variants of the sensor, and further information and technical data can be found in the catalog chapter sensor systems.

PGN-plus-P 50

Universal gripper

MMS-P programmable magnetic switch

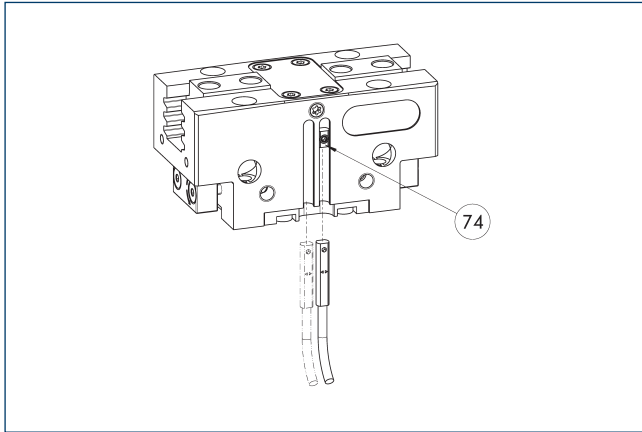

74 Limit stop for sensor

Position monitoring with two programmable positions per sensor. End position monitoring for mounting in the C-slot.

Description	ID	Often combined
Programmable magnetic switch		
MMSK-P 22-S-PNP	0301371	
MMS-P 22-S-M8-PNP	0301370	●
Connection cables		
KA GLN0804-LK-00500-A	0307767	●
KA GLN0804-LK-01000-A	0307768	
KA WLN0804-LK-00500-A	0307765	
KA WLN0804-LK-01000-A	0307766	
Clip for connector/socket		
CLI-M8	0301463	
Sensor distributor		
V2-M8-4P-2XM8-3P	0301380	

① One sensor is required per unit for monitoring two positions. Extension cables and sensor distributors are optionally available. Additional product variants of the sensor, and further information and technical data can be found in the catalog chapter sensor systems.

Analog position sensor MMS-A

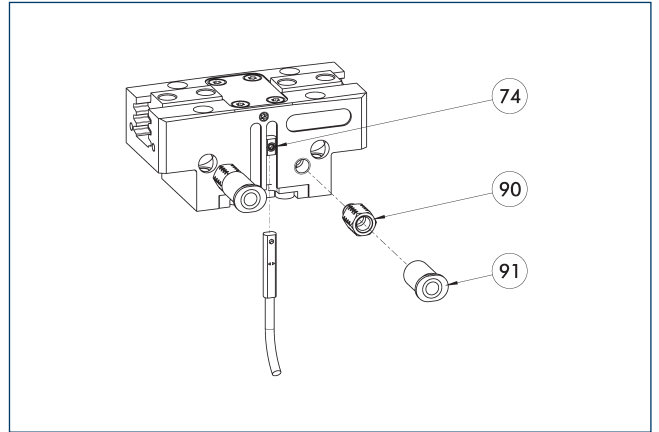

74 Limit stop for sensor

90 Flow control coupling, \varnothing 0.8 mm, for teaching process (ID 9953035/not included in the scope of delivery)

91 Air connection (not included in the scope of delivery)

Non-contact measuring, analog multi-position monitoring for any number of positions, easy to assemble in the C-slot. Can be programmed using MT magnetic teaching tool (included in the scope of delivery, ID 0301030) or ST plug teaching tool (optional). End position monitoring for mounting in the C-slot. If the ST plug teaching tools are listed in the chart provided, teaching is only possible with the ST teaching tools.

Description	ID	
Analog position sensor		
MMS 22-A-10V-M08	0315825	
MMS 22-A-10V-M12	0315828	

① One sensor is required per unit. The output voltage of the sensor differs according to the unit and is typically between 0.3 and 10 V. For teaching the sensor, a flow control coupling is required to reduce the speed during the teaching process. The resolution of the sensor can be smaller in the peripheral areas of the gripper. For further information on the product, see operating manual.

Flexible position sensor with MMS-A

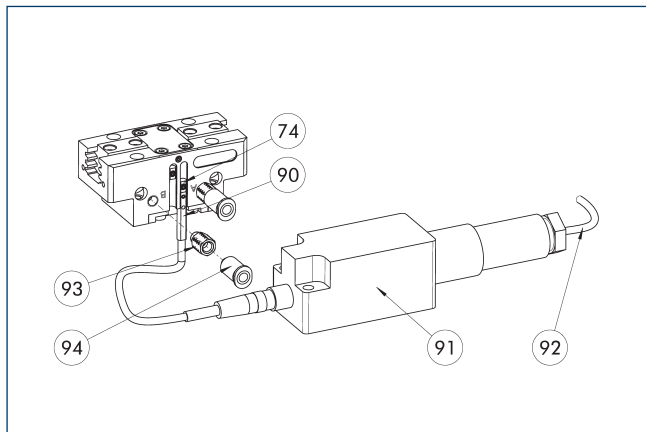

- ⑦④ Limit stop for sensor
- ⑨① MMS 22-A-... sensor
- ⑨② Connection cables
- ⑨③ Flow control coupling, \varnothing 0.8 mm, for teaching process (ID 9953035/not included in the scope of delivery)
- ⑨④ Air connection (not included in the scope of delivery)

Flexible position monitoring of up to five positions. Sensor can be taught using MT magnetic teaching tool (included in the scope of delivery, ID 0301030) or ST plug teaching tool (optional). If the ST plug teaching tools are listed in the table provided, teaching is only possible with the ST teaching tools.

Description	ID
Analog position sensor	
MMS 22-A-05V-M08	0315805
Evaluation electronics	
FPS-F5	0301805
Sensor Teaching Tool	
MT-MMS 22-PI	0301030
Connection cables	
KA BG16-L 12P-1000	0301801

- ① When using an FPS system, an MMS 22-A-05V, and evaluation electronics (FPS-F5) are required for each gripper. For teaching the sensor, a flow control coupling is required to reduce the speed during the teaching process. The resolution of the sensor can be smaller in the peripheral areas of the gripper. For further information on the product, see operating manual.

Programmable magnetic switch MMS-IO-Link

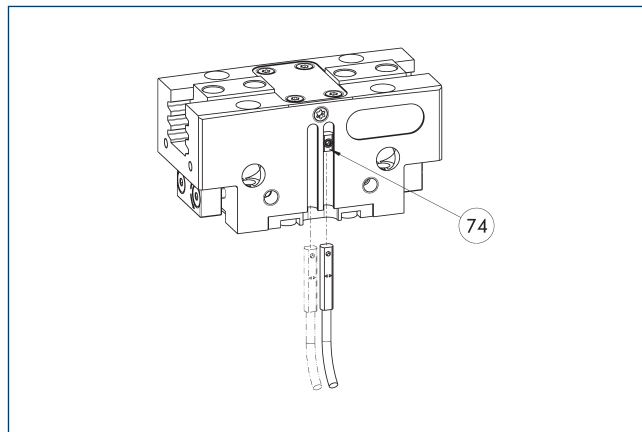

- ⑦④ Limit stop for sensor

Sensor for multi-position monitoring through detection of the complete gripper stroke. The sensor is mounted directly in the C-slot of the gripper. The sensor is programmed for the gripper via the IO-Link interface, Magnet teaching tool MT (included in scope of delivery; ID 0301030) or the ST plug teaching tool (not included in scope of delivery; ID 0301026). An IO-Link master is required for operation.

Description	ID
Programmable magnetic switch	
MMS 22-IO-L-M08	0315830
MMS 22-IO-L-M12	0315835

- ① One sensor is required for each gripper. No additional mounting kit is required – the gripper is equipped for use of the sensor by default. Further information and technical data can be found in the catalog chapter sensor systems.

PGN-plus-P 64

Universal gripper



Gripping force O.D. gripping

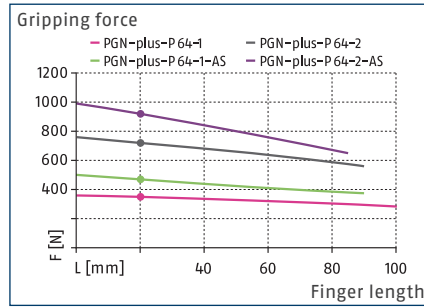

Gripping force I.D. gripping

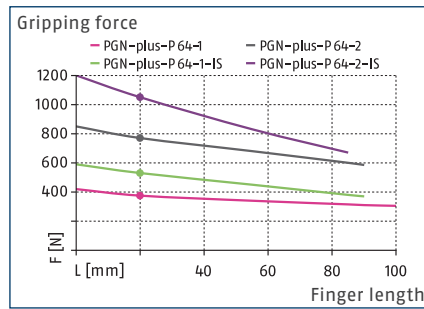

Dimensions and maximum loads

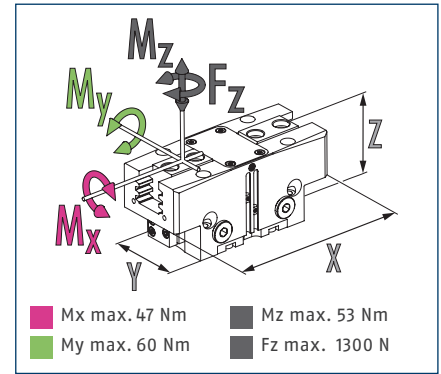

① The indicated moments and forces are static values, apply for each base jaw and may appear simultaneously. Loads may additionally occur to the moment produced by the gripping force itself.

Technical data

Description		PGN-plus-P 64-1	PGN-plus-P 64-2	PGN-plus-P 64-1-AS	PGN-plus-P 64-2-AS	PGN-plus-P 64-1-IS	PGN-plus-P 64-2-IS
ID		0318496	0318497	0318498	0318499	0318500	0318501
Stroke per jaw	[mm]	6	3	6	3	6	3
Closing/opening force	[N]	350/375	720/770	470/-	920/-	-/530	-/1050
Min. spring force	[N]			120	200	155	280
Weight	[kg]	0.27	0.27	0.35	0.35	0.35	0.35
Recommended workpiece weight	[kg]	1.75	3.6	1.75	3.6	1.75	3.6
Fluid consumption double stroke	[cm ³]	15	15	24	24	27	27
Min./nom./max. operating pressure	[bar]	2.5/6/8	2.5/6/8	4/6/6.5	4/6/6.5	4/6/6.5	4/6/6.5
Min./max. air purge pressure	[bar]	0.5/1	0.5/1	0.5/1	0.5/1	0.5/1	0.5/1
Closing/opening time	[s]	0.02/0.02	0.02/0.02	0.02/0.04	0.02/0.04	0.04/0.02	0.04/0.02
Closing/opening time with spring	[s]			0.07	0.07	0.07	0.07
Max. permissible finger length	[mm]	100	90	90	85	90	85
Max. permissible weight per finger	[kg]	0.4	0.4	0.4	0.4	0.4	0.4
IP protection class		40	40	40	40	40	40
Min./max. ambient temperature	[°C]	5/90	5/90	5/90	5/90	5/90	5/90
Repeat accuracy	[mm]	0.01	0.01	0.01	0.01	0.01	0.01
Dimensions X x Y x Z	[mm]	76 x 36 x 39	76 x 36 x 39	76 x 36 x 57	76 x 36 x 57	76 x 36 x 57	76 x 36 x 57
Options and their characteristics							
Dustproof version		1317542	1317543	1317545	1317548	1317549	1317558
IP protection class		64	64	64	64	64	64
Weight	[kg]	0.34	0.34	0.42	0.42	0.42	0.42
Corrosion-protected version		38318496	38318497	38318498	38318499	38318500	38318501
High-temperature version		39318496	39318497	39318498	39318499	39318500	39318501
Min./max. ambient temperature	[°C]	5/130	5/130	5/130	5/130	5/130	5/130
Precision version		0318502	0318503	0318504	0318505		
H1 grease version		1330366	1475839	1353812	1475842	1353813	1475845
Dustproof/H1 grease version		1475838	1475840	1475841	1475843	1475844	1475846
Weight	[kg]	0.34	0.34	0.42	0.42	0.42	0.42
IP protection class		64	64	64	64	64	64

① It may take a few 100 gripping cycles until the full gripping force (as indicated in the data table) will be available.

Main view

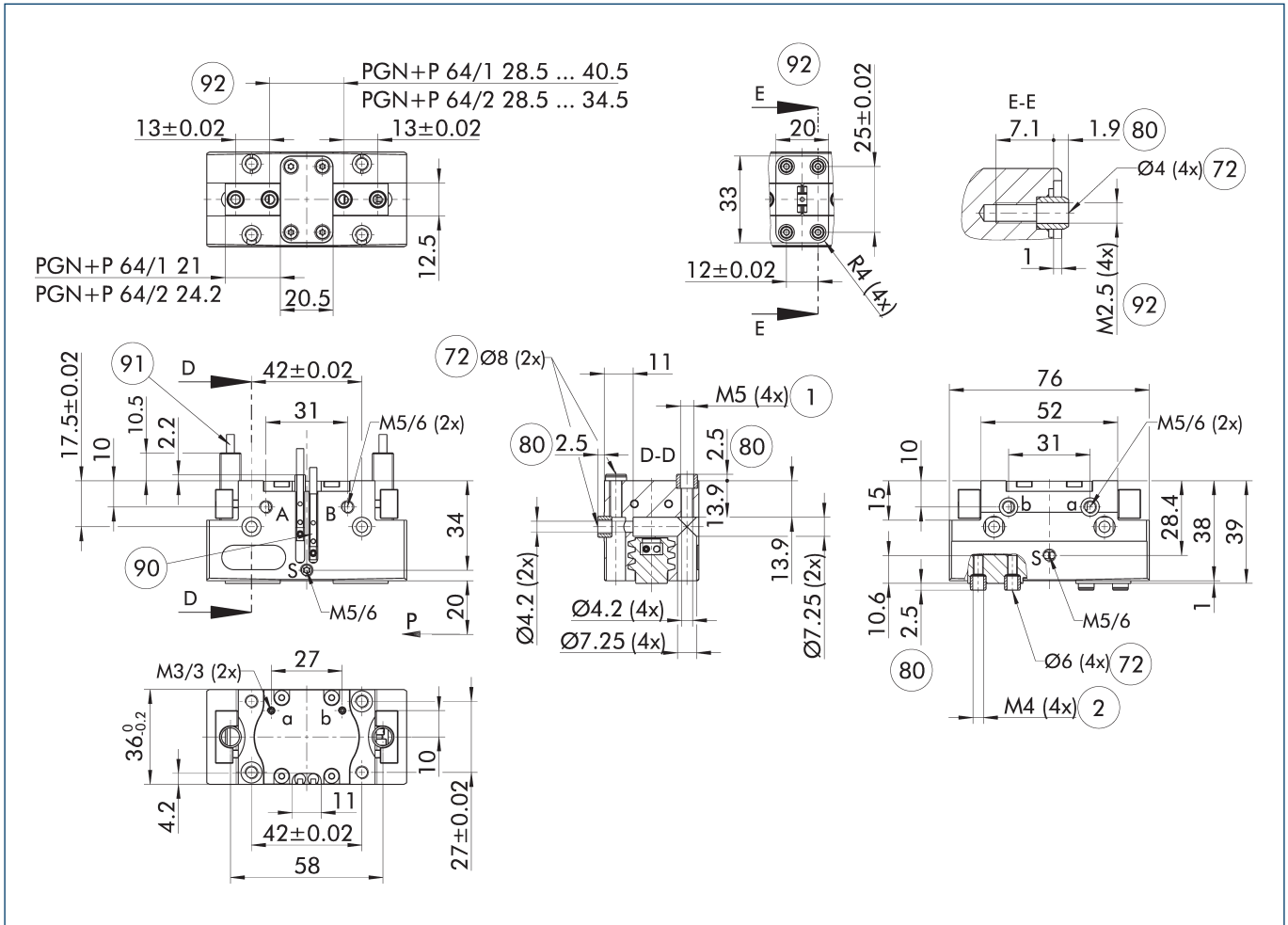

The drawing shows the gripper in the basic version with closed jaws, without dimensional consideration of the options described below.

① As an alternative/in addition to spring-assisted mechanical gripping force maintenance, the SDV-P pressure maintenance valve can be used for I.D. and O.D. gripping (see "Accessories" section of catalog).

- A, a Main / direct connection, gripper opening
- B, b Main / direct connection, gripper closing
- S Air purge connection
- ① Gripper connection
- ② Finger connection
- ⑦ Fit for centering sleeves

- ⑧ Depth of the centering sleeve hole in the counter part
- ⑨ Sensor MMS 22..
- ⑩ Sensor IN ...
- ⑪ Screw connection with centering for customized mounting (these centering sleeves are not included in the scope of delivery)

PGN-plus-P 64

Universal gripper

Maximum permitted finger projection

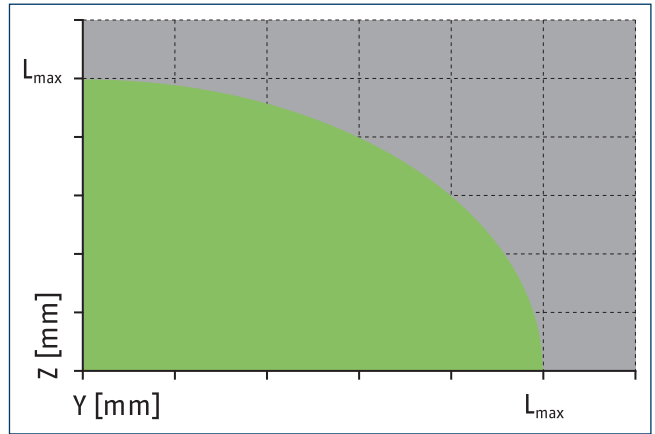
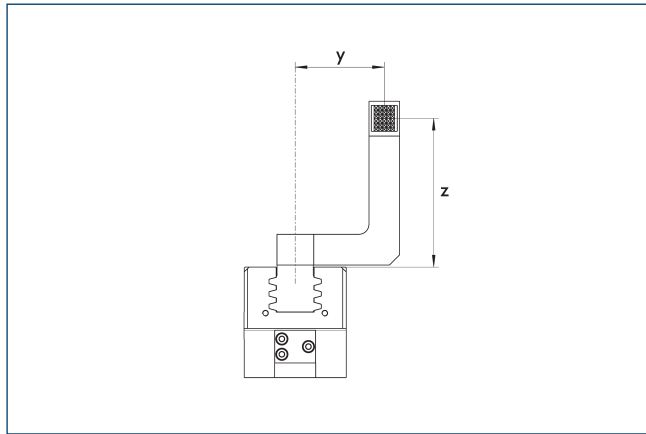

■ Permitted range ■ Inadmissible range

L_{max} is equivalent to the maximum permitted finger length, see the technical data table.

Hose-free direct connection M3

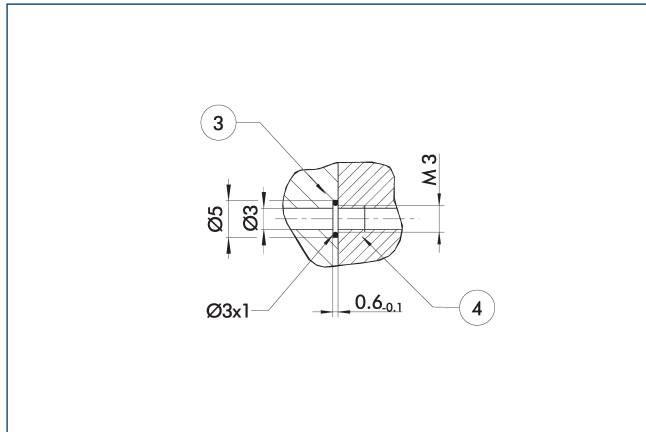

③ Adapter

④ Grippers

The direct connection is used for supplying compressed air without hoses. Instead, the pressure medium is fed through bore-holes in the mounting plate.

Gripping force maintenance version AS/IS

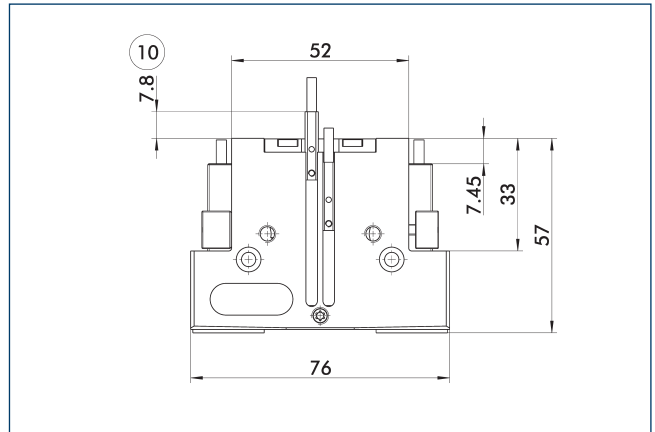

⑩ Projection applies only for AS version

The mechanical gripping force maintenance device ensures that a minimum clamping force will be applied even if there is a drop in pressure. In the AS/S variant this acts as a closing force, in the IS variant as an opening force. Besides this, gripping force maintenance can be used to increase gripping force or for single actuated gripping.

Dustproof version

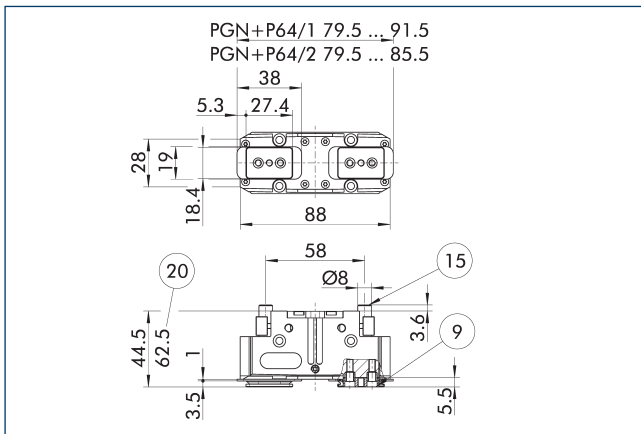

- ⑨ For mounting screw connection diagram, see basic version
- ⑮ Sealing bolt
- ⑳ For version AS/IS

The "dustproof" option increases the degree of protection against penetrating substances. The assembly diagram shifts by the height of the intermediate jaw. The finger length is still measured from the upper edge of the gripper housing.

Description	ID
Dust cover	
SAD PGN-plus-P 64	1347481

- ① The "dustproof" option can either be ordered as a pre-mounted gripper version or can be retrofitted to the gripper using the "SAD PGN-plus-P" retrofit kit.

Precision version

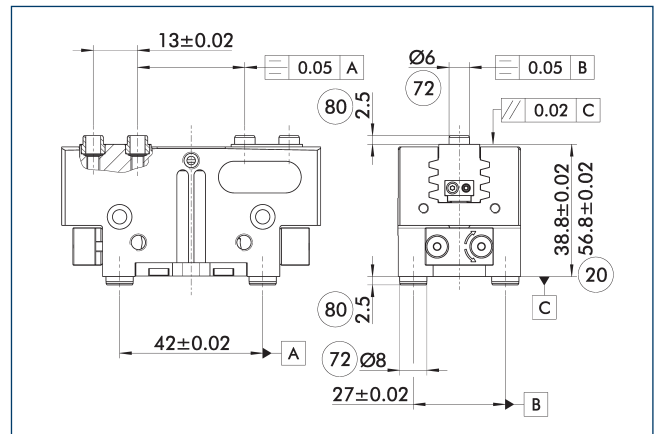

- ⑳ For version AS/IS
- ㉓ Fit for centering sleeves
- ⑧① Depth of the centering sleeve hole in the counter part

The indicated tolerances just refer to the variants of precision versions shown in the chart of technical specifications. All other variants of precision versions are available on request.

PGN-plus-P 64

Universal gripper

SDV-P pressure maintenance valve

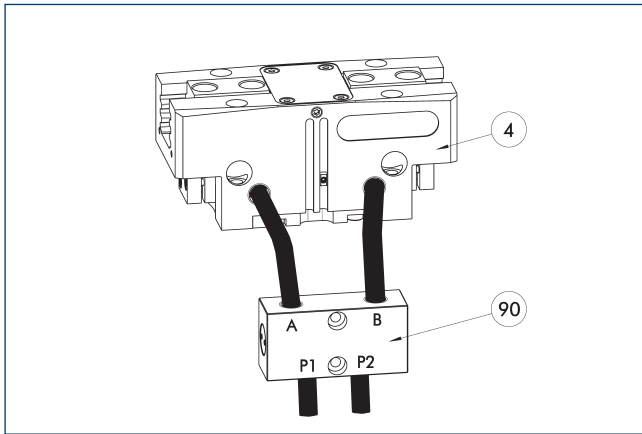

- ④ Grippers
- ⑨⑩ SDV-P pressure maintenance valve

The SDV-P pressure maintenance valve ensures in emergency STOP situations that the pressure in the piston chamber of pneumatic gripper, swivel, linear, and quick-change modules is temporarily maintained.

Description	ID	Recommended hose diameter [mm]
Pressure maintenance valve		
SDV-P 04	0403130	6
SDV-P 07	0403131	8
Pressure maintenance valve with air bleed screw		
SDV-P 04-E	0300120	6
SDV-P 07-E	0300121	8

- ① In order to achieve the specified closing and opening time for each gripper variant, the recommended hose diameter must be used. The direct allocation of the respective variant of the gripper for the respective SDV-P can be found at schunk.com.

SDV-P E-P pressure maintenance valve

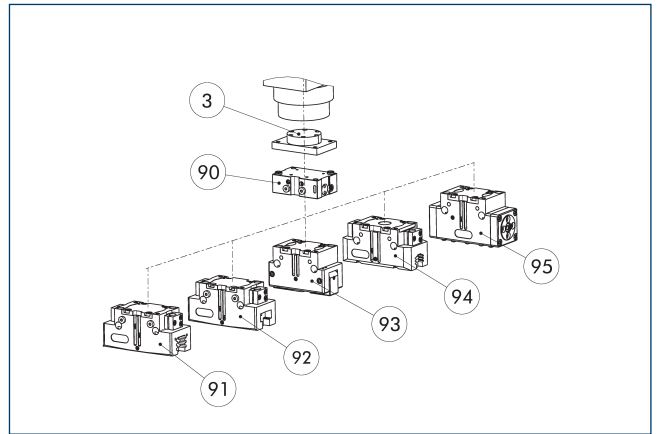

- ③ Adapter
- ⑨⑩ SDV-P E-P pressure maintenance valve
- ⑨① 2-finger parallel gripper
- ⑨② 2-finger parallel gripper JGP-P
- ⑨③ 2-finger angular gripper PWG-plus
- ⑨④ 2-finger parallel gripper PGB PGN-plus/PGN-plus-P
- ⑨⑤ Sealed DPG-plus gripper

The SDV-P E-P pressure maintenance valves ensure that the pressure in the piston chamber is maintained temporarily during an emergency stop. SDV-P E-P can be directly connected to the listed grippers without the need for additional pneumatic hoses.

Description	ID	
Pressure maintenance valve		
SDV-P 64-E-P	0300124	

Pneumatic positioning device PPD

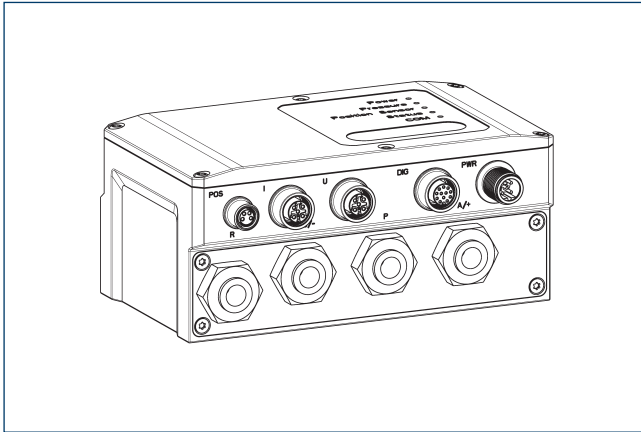

The PPD allows flexibility in all applications with pneumatic grippers through free positioning, gripping force and speed adjustment.

Description	ID	
Pneumatic positioning device		
PPD 10-IOL	1540698	
Adapter		
A GGN0804-1204-A	1540691	
IO-Link connection cable		
KA GGN1205-1212-IOL-00100-A	1540697	
Voltage supply connection cable - cable track compatible		
KA GLN12B05-LK-01000-A	1540660	
Cable extension		
KV GGN0804-I0-00150-A	1540662	
KV GGN0804-I0-00300-A	1540663	
Assembly set		
Assembly set PPD	1540705	

① In addition to the PPD, a position sensor (SCHUNK IO-Link sensor or analog sensor (4...20 mA)) is required.

Protective cover HUE PGN-plus 64

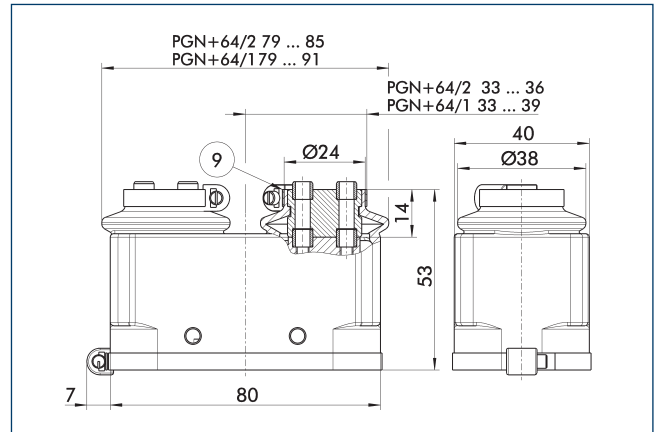

⑨ For mounting screw connection diagram, see basic version

The HUE protective cover fully protects the gripper against external influences. The cover is suitable for applications of up to IP65 if an additional sealing of the cover bottom is provided. For detailed information, please see the HUE series. The connection diagram shifts by the height of the intermediate jaw.

Description	ID	IP protection class
Protection cover		
HUE PGN-plus 64	0371480	65

① The HUE protective cover is not suitable for use on grippers with gripping force maintenance. An inductive monitoring of the gripper in connection with the HUE protective cover is not possible. SCHUNK recommends the use of magnetic sensors that are approved for the respective gripper variant.

PGN-plus-P 64

Universal gripper

BSWS jaw quick-change jaw systems

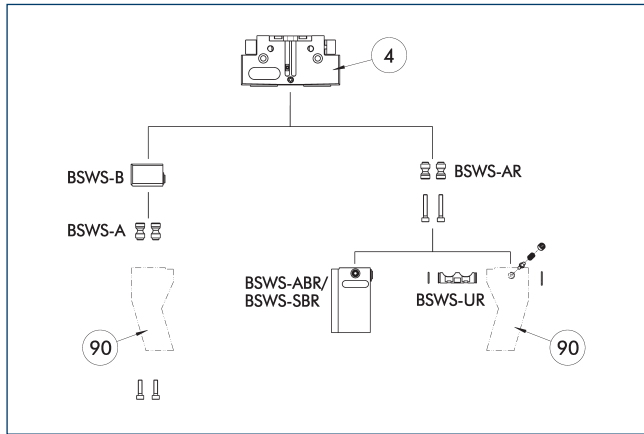

④ Grippers ⑨① Customized gripper fingers

There are various jaw quick-change systems available for the gripper. For detailed information, please refer to the corresponding product.

Description	ID	Scope of delivery
Jaw quick-change system adapter pin		
BSWS-A 64	0303022	2
BSWS-AR 64	0300092	2
Quick-change jaw system base		
BSWS-B 64	0303023	1
Jaw quick-change system finger blank		
BSWS-ABR-PGZN-plus 64	0300072	1
BSWS-SBR-PGZN-plus 64	0300082	1
Jaw quick-change system locking mechanism		
BSWS-UR 64	0302991	1

① If the operating pressure is higher than 6 bar, suitability for use beyond the application limits must be checked. Only systems that are listed in the table, can be used.

Fields of application

Series	Size	Variant	Suitability
PGN-plus-P	64	-1 (6 bar)	■■■■■
PGN-plus-P	64	-1-AS/1-IS (6 bar)	■■■■■
PGN-plus-P	64	-2 (6 bar)	■■■■■
PGN-plus-P	64	-2-AS/2-IS (6 bar)	■■■■■
Legend			
■■■■■	Can be combined without restrictions		
■■□□	Use with restrictions (see loading limits)		
□□□□	cannot be combined		

The load limits for describing the application limits can be found in the catalog chapter of the corresponding accessories.

Jaw quick-change system BSWS-M

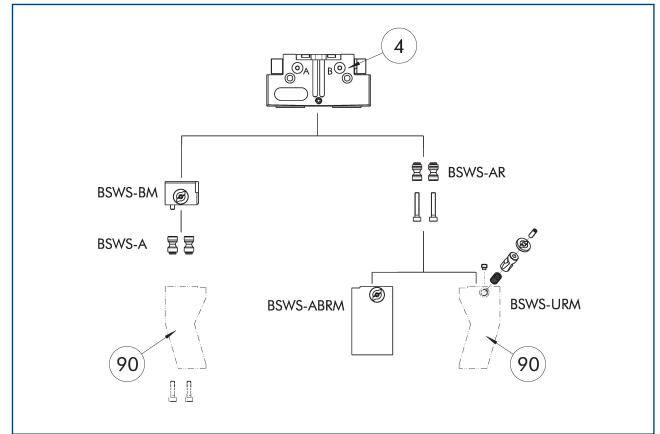

④ Grippers ⑨① Customized gripper fingers

There are various jaw quick-change systems available for the gripper. For detailed information, please refer to the corresponding product.

Description	ID	Scope of delivery
Jaw quick-change system adapter pin		
BSWS-A 64	0303022	2
BSWS-AR 64	0300092	2
Quick-change jaw system base		
BSWS-BM 64	1313900	1
Jaw quick-change system finger blank		
BSWS-ABRM-PGZN-plus 64	1420851	1
Jaw quick-change system locking mechanism		
BSWS-URM 64	1398401	1

① If the operating pressure is higher than 6 bar, suitability for use beyond the application limits must be checked. Only systems that are listed in the table, can be used.

Fields of application

Series	Size	Variant	Suitability
PGN-plus-P	64	-1 (6 bar)	■■■■■
PGN-plus-P	64	-1-AS/1-IS (6 bar)	■■■■■
PGN-plus-P	64	-2 (6 bar)	■■■■■
PGN-plus-P	64	-2-AS/2-IS (6 bar)	■■■■■
Legend			
■■■■■	Can be combined without restrictions		
■■□□	Use with restrictions (see loading limits)		
□□□□	cannot be combined		

The load limits for describing the application limits can be found in the catalog chapter of the corresponding accessories.

ZBA-L-plus 64 intermediate jaws

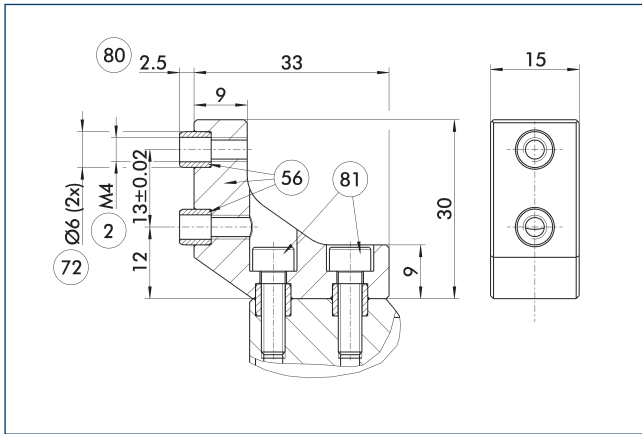

- ② Finger connection
- ⑤⑥ Included in the scope of delivery
- ⑦② Fit for centering sleeves
- ⑧① Depth of the centering sleeve hole in the counter part
- ⑧① Not included in the scope of delivery

The optional ZBA-L-plus intermediate jaws allow the screw connection diagram of the top jaws to be rotated by 90°. This makes it easier to design and produce top jaws (particularly for long versions) because no deep through-bores are required.

Description	ID	Material	Finger interface	Scope of delivery
Intermediate jaw				
ZBA-L-plus 64	0311722	Aluminum	PGN-plus 64	1

UZB 64 universal intermediate jaw

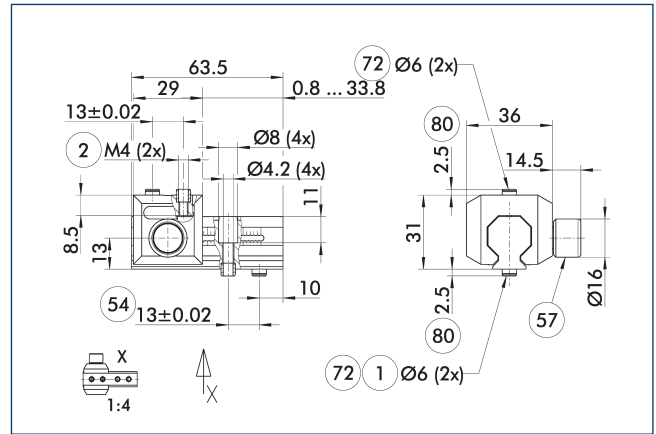

- ① Gripper connection
- ② Finger connection
- ⑤④ Optional right or left connection
- ⑤⑦ Locking
- ⑦② Fit for centering sleeves
- ⑧① Depth of the centering sleeve hole in the counter part

The drawing shows the UZB universal intermediate jaw.

Description	ID	Grid dimension
		[mm]
Universal intermediate jaw		
UZB 64	0300042	1.5
Finger blank		
ABR-PGZN-plus 64	0300010	
SBR-PGZN-plus 64	0300020	

① If the operating pressure is higher than 6 bar, suitability for use beyond the application limits must be checked.

Fields of application

Series	Size	Variant	Suitability
PGN-plus-P	64	-1 (6 bar)	■■■■
PGN-plus-P	64	-1-AS/1-IS (6 bar)	■■□□
PGN-plus-P	64	-2 (6 bar)	■■□□
PGN-plus-P	64	-2-AS/2-IS (6 bar)	□□□□
Legend			
■■■■	Can be combined without restrictions		
■■□□	Use with restrictions (see loading limits)		
□□□□	cannot be combined		

The load limits for describing the application limits can be found in the catalog chapter of the corresponding accessories.

PGN-plus-P 64

Universal gripper

Finger blanks ABR/SBR-PGZN-plus 64

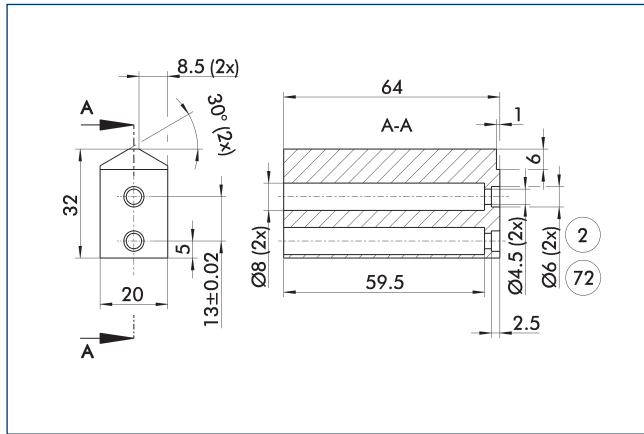

- 2 Finger connection
- 72 Fit for centering sleeves

The drawing shows the finger blank which can be reworked by the customer.

Description	ID	Material	Scope of delivery
Finger blank			
ABR-PGZN-plus 64	0300010	Aluminum (3.4365)	1
SBR-PGZN-plus 64	0300020	Steel (1.7131)	1

ⓘ In the PGL-plus-P gripper series, the use of finger blanks results in a limitation of the closing stroke. Please check this in detail in advance using the CAD data and adjust the reworking of the fingers accordingly.

Compensation unit AGE-F

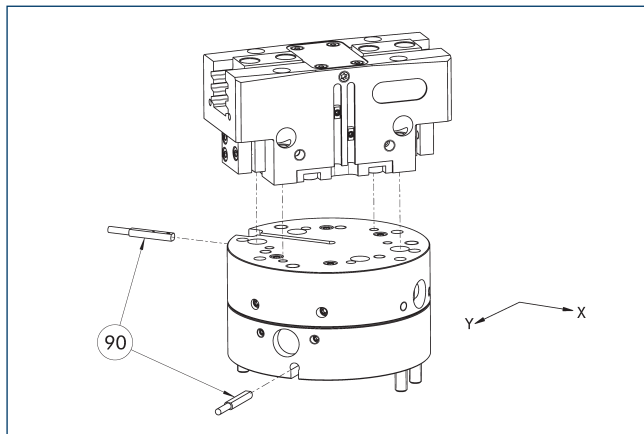

- 90 Monitoring

The unit has direct connection possibilities for different grippers of the PGN-plus, PGN-plus-P and PZN-plus series. For more detailed information, please refer to the main view.

Description	ID	Compensation XY	Reset force	Often combined
		[mm]	[N]	
Compensation unit				
AGE-F-XY-063-1	0324940	± 4	12	
AGE-F-XY-063-2	0324941	± 4	16	
AGE-F-XY-063-3	0324942	± 4	20	●

ⓘ Due to the interfering contour, monitoring of the gripper is not possible.

Tolerance compensation unit TCU

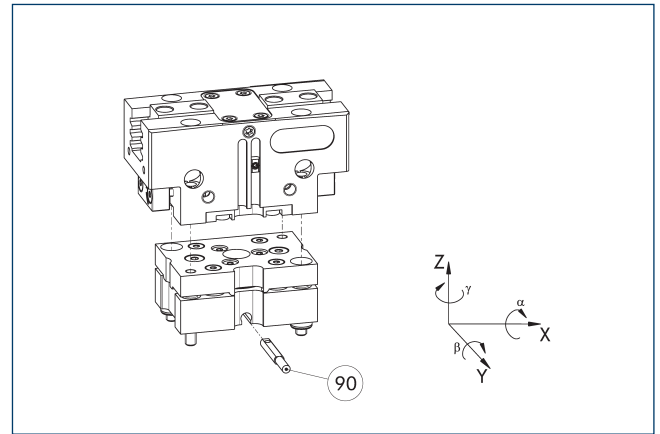

- 90 Monitoring of locking

Grippers can be directly mounted without an adapter plate. Tolerance compensation unit and gripper have an identical screw connection diagram. Therefore the tolerance compensation units can be assembled later. Please consider the additional assembly height of the tolerance compensation unit. For details please refer to our catalog robot accessories.

Description	ID	Locking	Deflection	Often combined
Compensation unit				
TCU-P-064-3-MV	0324774	yes	±1°/±1,5°/±2°	●
TCU-P-064-3-OV	0324775	no	±1°/±1,5°/±2°	

Adapter plate for PGN-plus 64

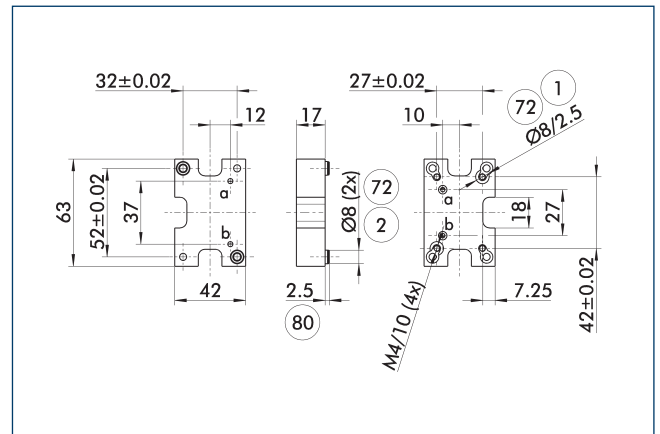

- 1 Robot-side connection
- 2 Tool-side connection
- 72 Fit for centering sleeves
- 80 Depth of the centering sleeve hole in the counter part

The adapter plate has integrated air feed-throughs in order to be able to use the hose-free direct connection of the appropriate gripper.

Description	ID
Tool side	
A-CWA-080-064-P	0305784

Compact change system for grippers

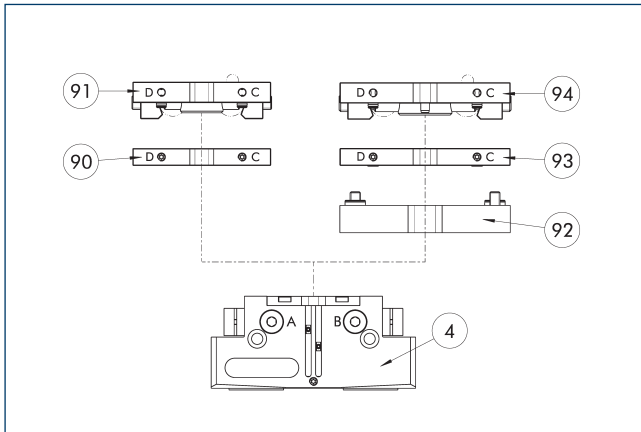

- ④ Grippers
- ⑨② A-CWA adapter plate
- ⑨① CWA compact change adapter
- ⑨③ CWA compact change adapter
- ⑨① CWK compact change master
- ⑨④ CWK compact change master

Grippers can be directly mounted without an adapter plate. For details see our catalog Gripping or Robot Accessories.

Description	ID
Tool side	
A-CWA-080-064-P	0305784
CWA compact change adapter	
CWA-064-P	0305765
CWK compact change master	
CWK-064-P	0305764

Add-on valves for single grippers

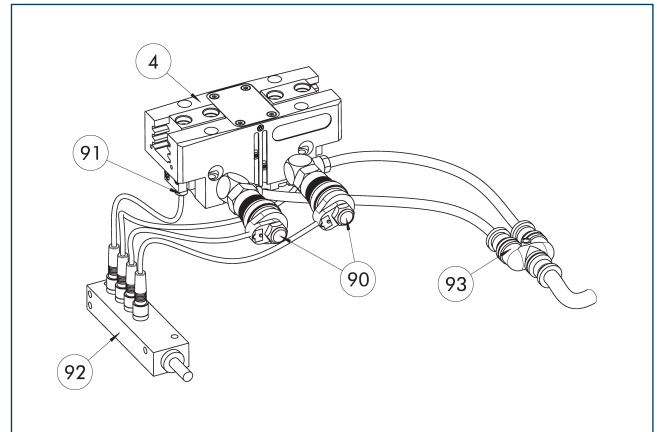

- ④ Grippers
- ⑨② Sensor distributor
- ⑨① Micro valves
- ⑨③ Y distributor
- ⑨① Sensor

The set of attachment valves reduces the compressed air consumption as there is no need to ventilate or bleed the supply lines. This can also reduce cycle time. The hose-free direct assembly of the micro valves reduces the hosing effort for the gripper. To further simplify electrical connection of the valves and sensors, their signals can be bundled via an optional distributor.

Description	ID	Often combined
Add-on valve set		
ABV-MV15-M5	0303323	
ABV-MV15-M5-V2-M8	0303386	
ABV-MV15-M5-V4-M8	0303356	●

- ① A set of add-on valves ABV is required per actuator. The ABV set contains two 3/2 micro valves, an Y-distributor for compressed air supply and optionally a sensor distributor with two or four inputs or outputs. Sensors for monitoring the gripper need to be ordered separately. Pneumatic hoses are not included in the scope of delivery.

PGN-plus-P 64

Universal gripper

Add-on valves for double grippers

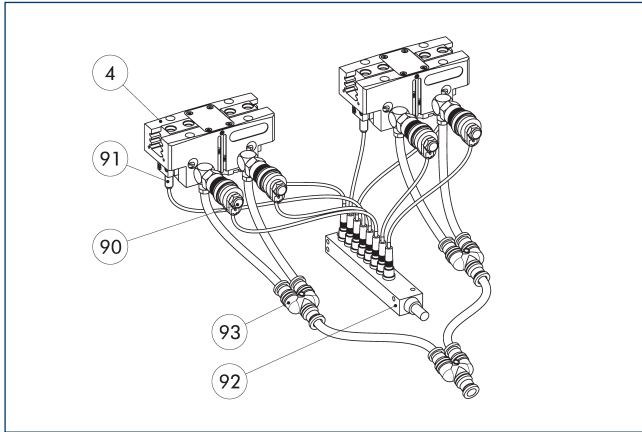

- ④ Grippers
- ⑨② Sensor distributor
- ⑨① Micro valves
- ⑨③ Y distributor
- ⑨① Sensor

The add-on valve set reduces compressed air consumption as there is no need to ventilate or bleed the supply lines. This can also reduce cycle time. The hose-free direct assembly of the micro valves reduces the hosing effort for the gripper. To further simplify electrical connection of the valves and sensors, their signals can be bundled via a distributor.

Description	ID
Add-on valve set	
ABV-MV15-M5-V8-M8	0303357

ⓘ A set of add-on valves ABV is required per double gripping unit. The ABV set contains four 3/2 microvalves, three Y-distributors for compressed air supply and a sensor distributor with eight inputs or outputs. Sensors for monitoring the gripper need to be ordered separately. Pneumatic hoses are not included in the scope of delivery.

Modular Assembly Automation

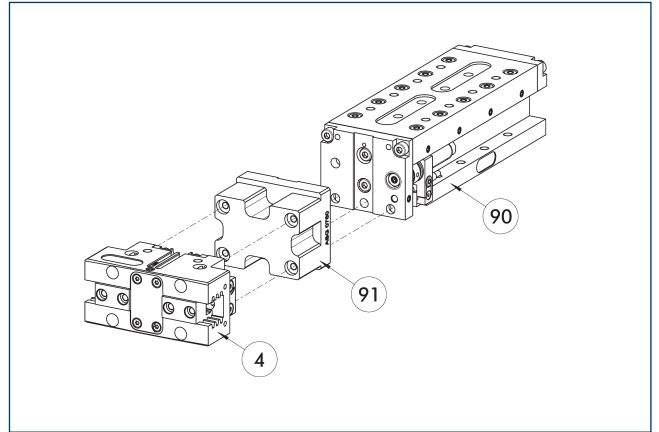

- ④ Grippers
- ⑨① ASG adapter plate
- ⑨① Linear module CLM/KLM/LM/ELP/ELM/ELS/HLM

Grippers and linear modules can be combined with standard adapter plates from the modular assembly system. For more information see our main catalog "Modular Assembly Automation".

Inductive proximity switches

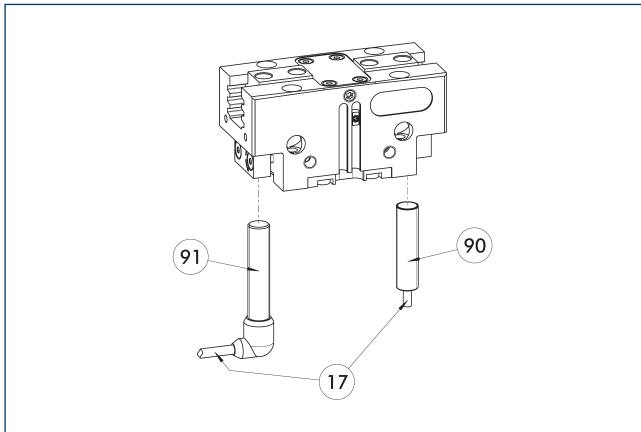

- ①⑦ Cable outlet
- ①⑨ Sensor IN...-SA
- ①⑩ Sensor IN ...

Directly mounted end position monitoring.

Description	ID	Often combined
Inductive proximity switches		
IN 80-S-M12	0301578	
IN 80-S-M8	0301478	●
INK 80-S	0301550	
Inductive proximity switch with lateral cable outlet		
IN 80-S-M12-SA	0301587	
IN 80-S-M8-SA	0301483	●
INK 80-S-SA	0301566	
Connection cables		
KA BG08-L 3P-0300-PNP	0301622	●
KA BG08-L 3P-0500-PNP	0301623	
KA BG12-L 3P-0500-PNP	30016369	
KA BW08-L 3P-0300-PNP	0301594	
KA BW08-L 3P-0500-PNP	0301502	
KA BW12-L 3P-0300-PNP	0301503	
KA BW12-L 3P-0500-PNP	0301507	
Clip for connector/socket		
CLI-M12	0301464	
CLI-M8	0301463	
Cable extension		
KV BG12-SG12 3P-0030-PNP	0301999	
KV BG12-SG12 3P-0060-PNP	0301998	
KV BW08-SG08 3P-0030-PNP	0301495	
KV BW08-SG08 3P-0100-PNP	0301496	
KV BW08-SG08 3P-0200-PNP	0301497	●
KV BW12-SG12 3P-0030-PNP	0301595	
KV BW12-SG12 3P-0100-PNP	0301596	
KV BW12-SG12 3P-0200-PNP	0301597	
Sensor distributor		
V2-M12	0301776	●
V2-M8	0301775	●
V4-M8	0301746	
V8-M8	0301751	

- ① Two sensors are required per unit for monitoring two positions. On option, extension cables and sensor distributors are available. Additional product variants of the sensor, and further information and technical data can be found in the catalog chapter sensor system.

Flexible position sensor

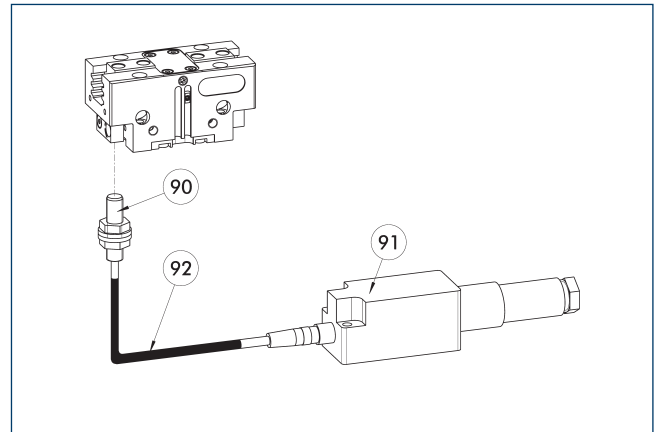

- ①⑩ FPS-S sensor
- ①⑩ FPS-F5 evaluation electronic
- ①② Cable extension

Flexible position monitoring of up to five positions.

Description	ID	
Attachment kit for FPS		
AS-FPS-PGN-plus-P 64/80	1363890	
Sensor		
FPS-S M8	0301704	
Evaluation electronics		
FPS-F5	0301805	
Cable extension		
KV BG08-SG08 3P-0050	0301598	
KV BG08-SG08 3P-0100	0301599	

- ① When using an FPS system, an FPS sensor (FPS-S) as well as an electronic processor (FPS-F5 / F5 T) are required for each gripper as well as a mounting kit (AS), if listed. Cable extensions (KV) are optionally available – see catalog chapter "Accessories."

PGN-plus-P 64

Universal gripper

Electronic magnetic switch MMS

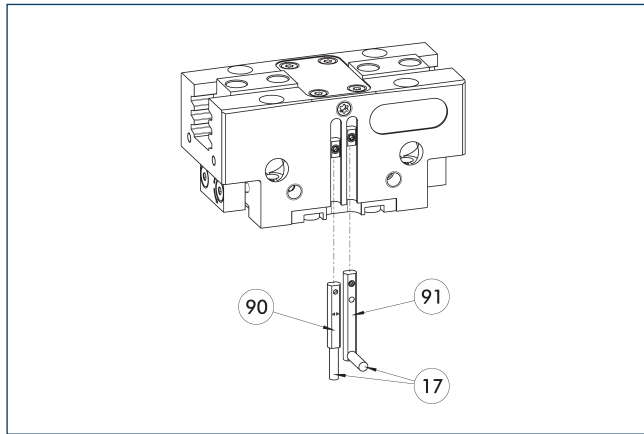

- ①7 Cable outlet
- ①91 Sensor MMS 22...-SA
- ①90 Sensor MMS 22..

End position monitoring for mounting in the C-slot.

Description	ID	Often combined
Electronic magnetic switch		
MMS 22-S-M8-PNP	0301032	●
MMSK 22-S-PNP	0301034	
Electronic magnetic switches with lateral cable outlet		
MMS 22-S-M8-PNP-SA	0301042	●
MMSK 22-S-PNP-SA	0301044	
Connection cables		
KA BG08-L 3P-0300-PNP	0301622	●
KA BG08-L 3P-0500-PNP	0301623	
KA BW08-L 3P-0300-PNP	0301594	
KA BW08-L 3P-0500-PNP	0301502	
Clip for connector/socket		
CLI-M8	0301463	
Cable extension		
KV BW08-SG08 3P-0030-PNP	0301495	
KV BW08-SG08 3P-0100-PNP	0301496	
KV BW08-SG08 3P-0200-PNP	0301497	●
Sensor distributor		
V2-M8	0301775	●
V4-M8	0301746	
V8-M8	0301751	

- ① Two sensors are required per unit for monitoring two positions. On option, extension cables and sensor distributors are available. Additional product variants of the sensor, and further information and technical data can be found in the catalog chapter sensor system.

Programmable magnetic switch MMS 22-PI1

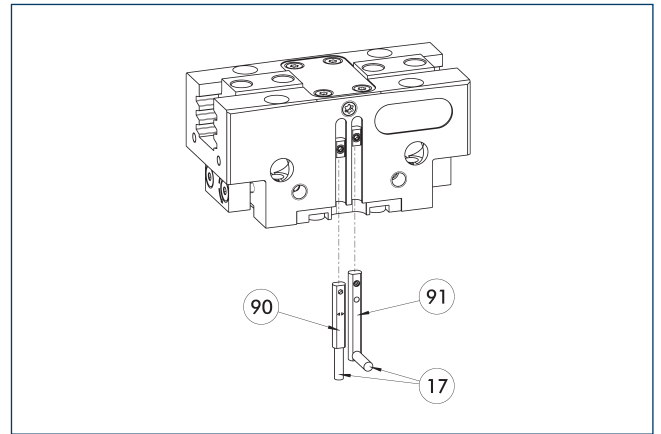

- ①7 Cable outlet
- ①91 Sensor MMS 22 ..-PI1...-SA
- ①90 Sensor MMS 22 PI1...

Position monitoring with one programmable position per sensor and integrated electronic system in the sensor. Can be programmed using MT magnetic teaching tool (included in the scope of delivery, ID 0301030) or ST plug teaching tool (optional). End position monitoring for mounting in the C-slot. If the ST plug teaching tools are listed in the table provided, teaching is only possible with the ST teaching tools.

Description	ID	Often combined
Programmable magnetic switch		
MMS 22-PI1-S-M8-PNP	0301160	●
MMSK 22-PI1-S-PNP	0301162	
Programmable magnetic switch with lateral cable outlet		
MMS 22-PI1-S-M8-PNP-SA	0301166	●
MMSK 22-PI1-S-PNP-SA	0301168	
Programmable magnetic switch with stainless steel housing		
MMS 22-PI1-S-M8-PNP-HD	0301110	●
MMSK 22-PI1-S-PNP-HD	0301112	

- ① Two sensors are required per unit for monitoring two positions. On option, extension cables and sensor distributors are available. Additional product variants of the sensor, and further information and technical data can be found in the catalog chapter sensor system.

Programmable magnetic switch MMS 22-PI2

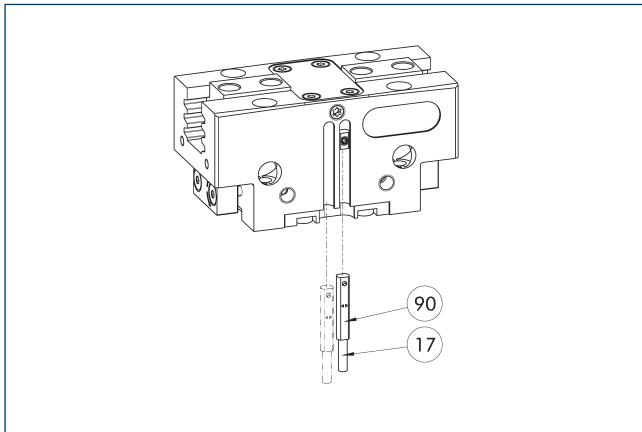

⑰ Cable outlet ⑨① MMS 22...-PI2-... sensor

Position monitoring with two programmable positions per sensor and electronics integrated in the sensor. Can be programmed using MT magnetic teaching tool (included in the scope of delivery, ID 0301030) or ST plug teaching tool (optional). End position monitoring for mounting in the C-slot. If the ST plug teaching tools are listed in the table provided, teaching is only possible with the ST teaching tools.

Description	ID	Often combined
Programmable magnetic switch		
MMS 22-PI2-S-M8-PNP	0301180	●
MMSK 22-PI2-S-PNP	0301182	
Programmable magnetic switch with lateral cable outlet		
MMS 22-PI2-S-M8-PNP-SA	0301186	●
MMSK 22-PI2-S-PNP-SA	0301188	
Programmable magnetic switch with stainless steel housing		
MMS 22-PI2-S-M8-PNP-HD	0301130	●
MMSK 22-PI2-S-PNP-HD	0301132	

① One sensor is required per unit for monitoring two positions. Extension cables and sensor distributors are optionally available. Additional product variants of the sensor, and further information and technical data can be found in the catalog chapter sensor systems.

MMS-P programmable magnetic switch

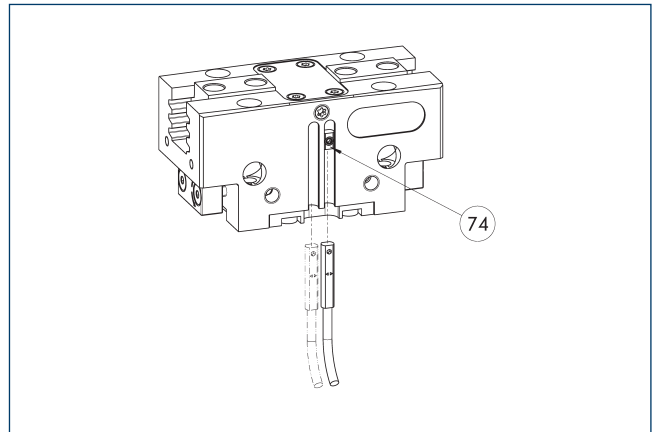

⑦④ Limit stop for sensor

Position monitoring with two programmable positions per sensor. End position monitoring for mounting in the C-slot.

Description	ID	Often combined
Programmable magnetic switch		
MMSK-P 22-S-PNP	0301371	
MMS-P 22-S-M8-PNP	0301370	●
Connection cables		
KA GLN0804-LK-00500-A	0307767	●
KA GLN0804-LK-01000-A	0307768	
KA WLN0804-LK-00500-A	0307765	
KA WLN0804-LK-01000-A	0307766	
Clip for connector/socket		
CLI-M8	0301463	
Sensor distributor		
V2-M8-4P-2XM8-3P	0301380	

① One sensor is required per unit for monitoring two positions. Extension cables and sensor distributors are optionally available. Additional product variants of the sensor, and further information and technical data can be found in the catalog chapter sensor systems.

PGN-plus-P 64

Universal gripper

Analog position sensor MMS-A

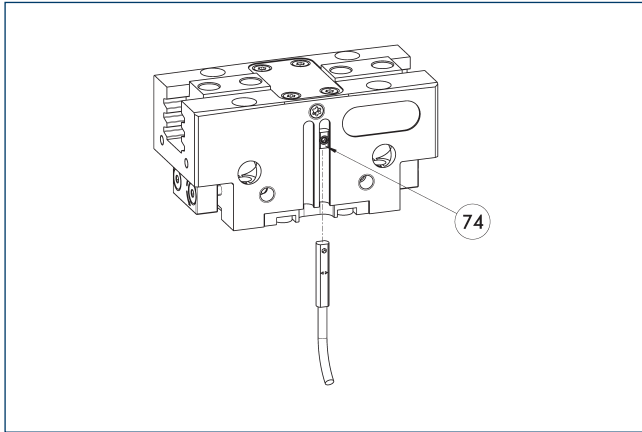

74 Limit stop for sensor

Non-contact measuring, analog multi-position monitoring for any number of positions, easy to assemble in the C-slot. Can be programmed using MT magnetic teaching tool (included in the scope of delivery, ID 0301030) or ST plug teaching tool (optional). End position monitoring for mounting in the C-slot. If the ST plug teaching tools are listed in the chart provided, teaching is only possible with the ST teaching tools.

Description	ID	
Analog position sensor		
MMS 22-A-10V-M08	0315825	
MMS 22-A-10V-M12	0315828	

① One sensor is required for each gripper. No additional mounting kit is required – the gripper is equipped for use of the sensor by default. Further information and technical data can be found in the catalog chapter sensor systems.

Flexible position sensor with MMS-A

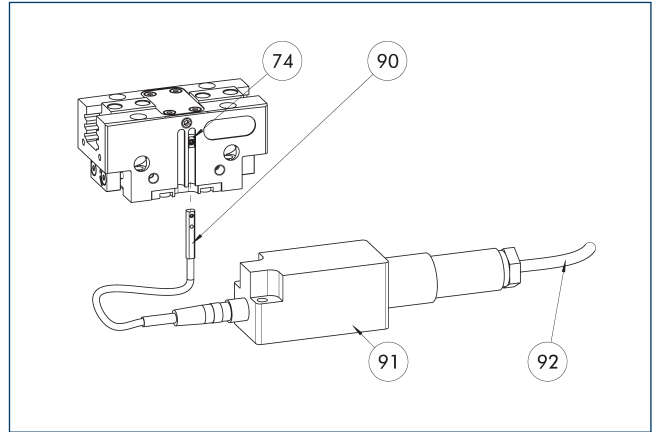

74 Limit stop for sensor

90 MMS 22-A-... sensor

91 FPS-F5 evaluation electronic

92 Connection cables

Flexible position monitoring of up to five positions. Sensor can be taught using MT magnetic teaching tool (included in the scope of delivery, ID 0301030) or ST plug teaching tool (optional). If the ST plug teaching tools are listed in the table provided, teaching is only possible with the ST teaching tools.

Description	ID	
Analog position sensor		
MMS 22-A-05V-M08	0315805	
Evaluation electronics		
FPS-F5	0301805	
Sensor Teaching Tool		
MT-MMS 22-PI	0301030	
Connection cables		
KA BG16-L 12P-1000	0301801	

① When using an FPS system, one MMS 22-A-05V and one evaluation electronics (FPS-F5) are required per each gripper, as well as an attachment kit (AS), if listed. On option, cable extensions (KV) are available – see catalog chapter “Accessories.”

Programmable magnetic switch MMS-IO-Link

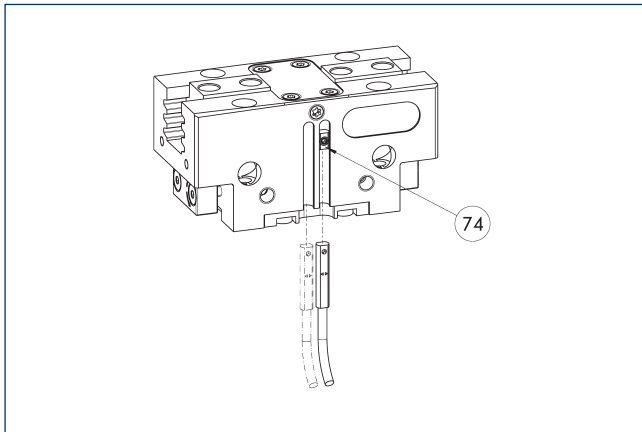

74 Limit stop for sensor

Sensor for multi-position monitoring through detection of the complete gripper stroke. The sensor is mounted directly in the C-slot of the gripper. The sensor is programmed for the gripper via the IO-Link interface, Magnet teaching tool MT (included in scope of delivery; ID 0301030) or the ST plug teaching tool (not included in scope of delivery; ID 0301026). An IO-Link master is required for operation.

Description	ID	
Programmable magnetic switch		
MMS 22-IO-L-M08	0315830	
MMS 22-IO-L-M12	0315835	

① One sensor is required for each gripper. No additional mounting kit is required – the gripper is equipped for use of the sensor by default. Further information and technical data can be found in the catalog chapter sensor systems.

APS-Z80 analog position sensor

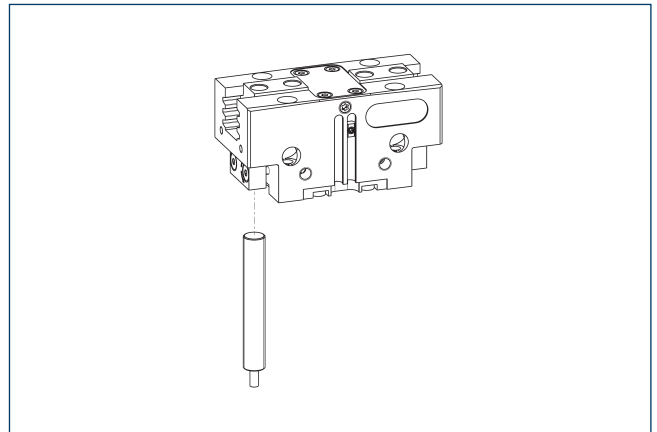

Non-contact measuring, analog multi-position monitoring for any number of positions.

Description	ID	Often combined
Mounting kit for APS-Z80		
AS-APS-Z80-PGN-plus-P 64-1	1366196	
AS-APS-Z80-PGN-plus-P 64-2	1366200	
Analog position sensor		
APS-Z80-K	0302072	
APS-Z80-M8	0302070	●

① When using an APS system, one mounting kit (AS-APS-Z80) and one APS-Z80 sensor is required per gripper. The resolution of the sensor can be lower in the peripheral areas of the gripper. You can find further information on the product in the operating manual.

PGN-plus-P 64

Universal gripper

APS-M1 analog position sensor

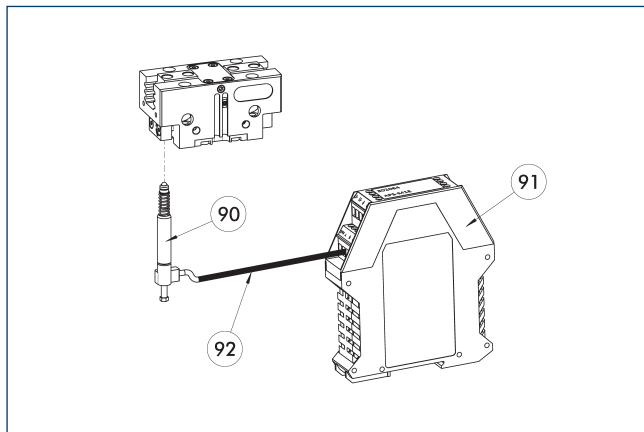

- ⑨⑩ APS-M1S sensor
- ⑨① APS-M1E electronic processor
- ⑨② APS-K extension cable

Analog multi position monitoring for any desired positions

Description	ID	
Mounting kit for APS-M1		
AS-APS-M1-PGN-plus-P 64-1	1363716	
AS-APS-M1-PGN-plus-P 64-2	1363721	
Analog position sensor		
APS-M1S	0302062	
Connection cables		
APS-K0200	0302066	
APS-K0700	0302068	
Evaluation electronics		
APS-M1E	0302064	

- ① When using an APS system, for each gripper an attachment kit (AS-APS-M1), an APS-M1S sensor (incl. 3 m cable) as well as an electronics (APS-M1e) are required. An extension cable (APS-K) can be connected between the sensor and the electronics as an option. The max. cable length between the sensor and the electronics is 10 m, between the electronics and their control unit (PLC) it is max. 1 m.

PGN-plus-P 80

Universal gripper



Gripping force O.D. gripping

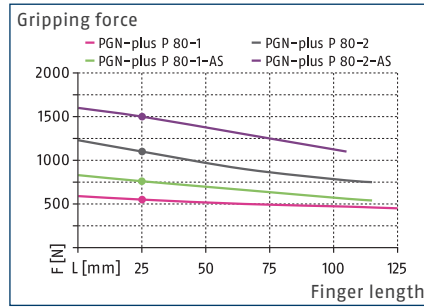

Gripping force I.D. gripping

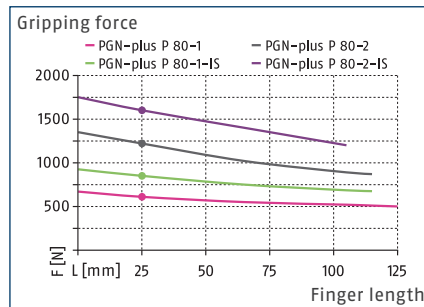

Dimensions and maximum loads

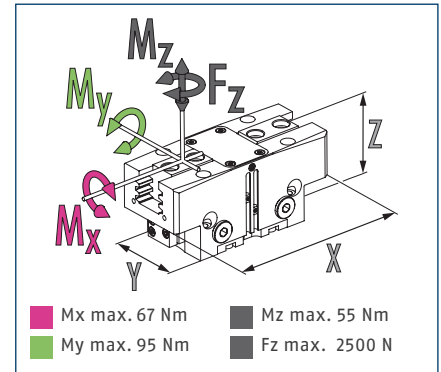

① The indicated moments and forces are static values, apply for each base jaw and may appear simultaneously. Loads may additionally occur to the moment produced by the gripping force itself.

Technical data

Description		PGN-plus-P 80-1	PGN-plus-P 80-2	PGN-plus-P 80-1-AS	PGN-plus-P 80-2-AS	PGN-plus-P 80-1-IS	PGN-plus-P 80-2-IS
ID		0318520	0318521	0318522	0318523	0318524	0318525
Stroke per jaw	[mm]	8	4	8	4	8	4
Closing/opening force	[N]	550/610	1100/1220	760/-	1500/-	-/850	-/1600
Min. spring force	[N]			210	400	240	380
Weight	[kg]	0.51	0.51	0.63	0.63	0.63	0.63
Recommended workpiece weight	[kg]	2.75	5.5	2.75	5.5	2.75	5.5
Fluid consumption double stroke	[cm³]	29	29	44	44	52	52
Min./nom./max. operating pressure	[bar]	2.5/6/8	2.5/6/8	4/6/6.5	4/6/6.5	4/6/6.5	4/6/6.5
Min./max. air purge pressure	[bar]	0.5/1	0.5/1	0.5/1	0.5/1	0.5/1	0.5/1
Closing/opening time	[s]	0.035/0.035	0.035/0.035	0.03/0.05	0.03/0.05	0.05/0.03	0.05/0.03
Closing/opening time with spring	[s]			0.08	0.08	0.08	0.08
Max. permissible finger length	[mm]	125	115	115	105	115	105
Max. permissible weight per finger	[kg]	0.7	0.7	0.7	0.7	0.7	0.7
IP protection class		40	40	40	40	40	40
Min./max. ambient temperature	[°C]	5/90	5/90	5/90	5/90	5/90	5/90
Repeat accuracy	[mm]	0.01	0.01	0.01	0.01	0.01	0.01
Dimensions X x Y x Z	[mm]	96 x 42 x 49	96 x 42 x 49	96 x 42 x 67	96 x 42 x 67	96 x 42 x 67	96 x 42 x 67
Options and their characteristics							
Dustproof version		1317561	1317563	1317564	1317565	1317568	1317569
IP protection class		64	64	64	64	64	64
Weight	[kg]	0.58	0.58	0.7	0.7	0.7	0.7
Corrosion-protected version		38318520	38318521	38318522	38318523	38318524	38318525
High-temperature version		39318520	39318521	39318522	39318523	39318524	39318525
Min./max. ambient temperature	[°C]	5/130	5/130	5/130	5/130	5/130	5/130
Precision version		0318526	0318527	0318528	0318529		
H1 grease version		1353814	1360962	1353815	1475849	1353816	1475852
Dustproof/H1 grease version		1408195	1475847	1475848	1475850	1475851	1475853
Weight	[kg]	0.58	0.58	0.7	0.7	0.7	0.7
IP protection class		64	64	64	64	64	64

① It may take a few 100 gripping cycles until the full gripping force (as indicated in the data table) will be available.

Main view

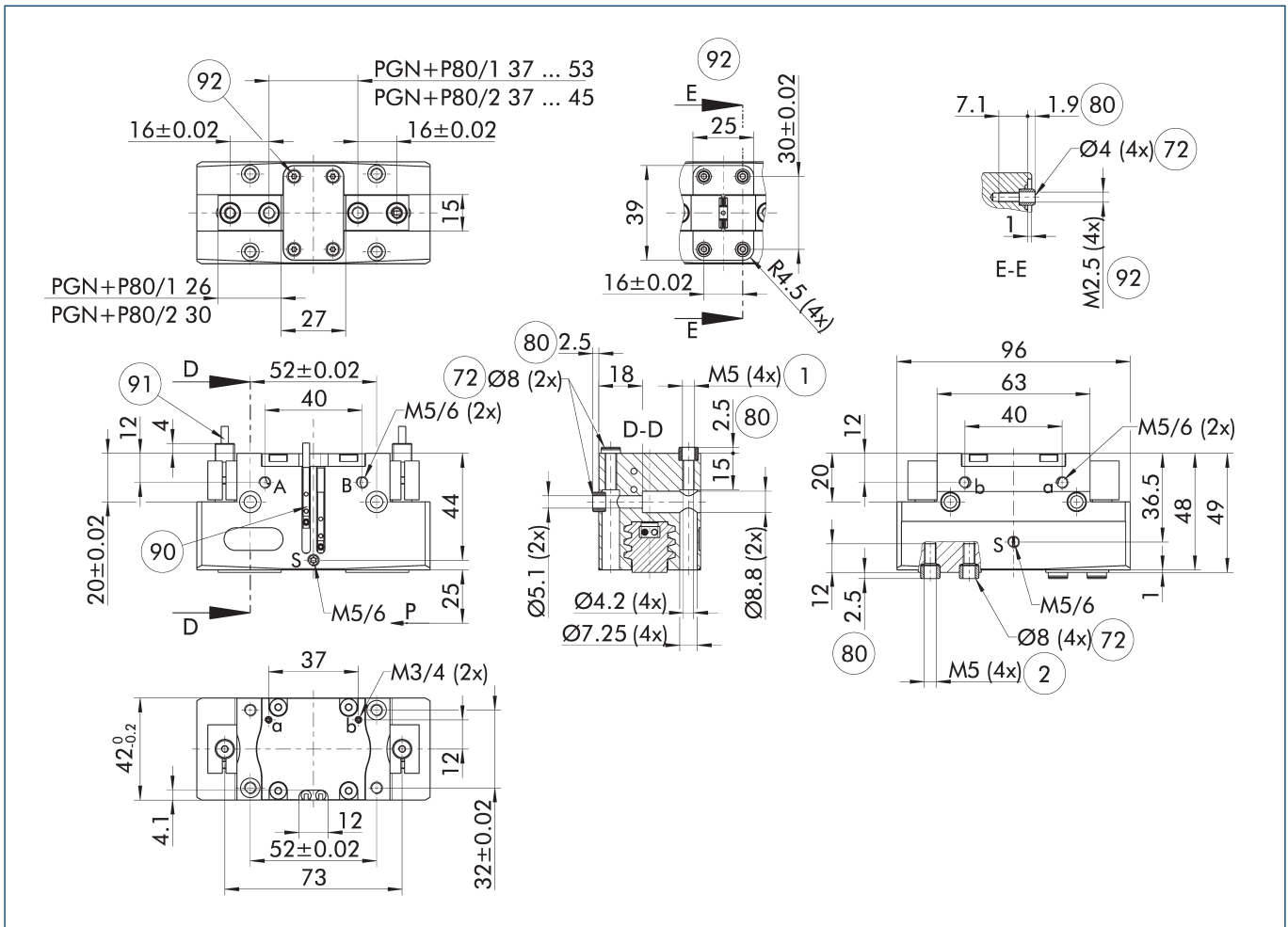

The drawing shows the gripper in the basic version with closed jaws, without dimensional consideration of the options described below.

① As an alternative/in addition to spring-assisted mechanical gripping force maintenance, the SDV-P pressure maintenance valve can be used for I.D. and O.D. gripping (see "Accessories" section of catalog).

- A, a Main / direct connection, gripper opening
- B, b Main / direct connection, gripper closing
- S Air purge connection
- ① Gripper connection
- ② Finger connection
- ⑦② Fit for centering sleeves

- ⑧① Depth of the centering sleeve hole in the counter part
- ⑨① Sensor MMS 22..
- ⑨① Sensor IN ...
- ⑨② Screw connection with centering for customized mounting (these centering sleeves are not included in the scope of delivery)

PGN-plus-P 80

Universal gripper

Maximum permitted finger projection

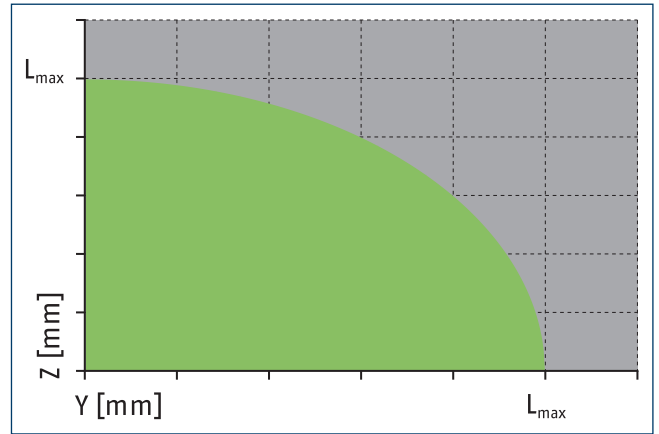
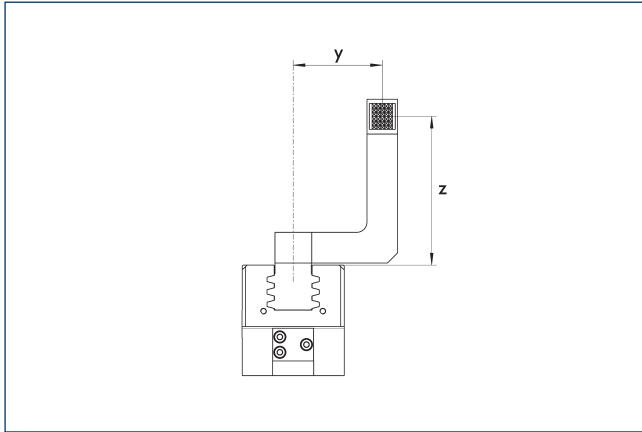

■ Permitted range

■ Inadmissible range

L^{max} is equivalent to the maximum permitted finger length, see the technical data table.

Hose-free direct connection M3

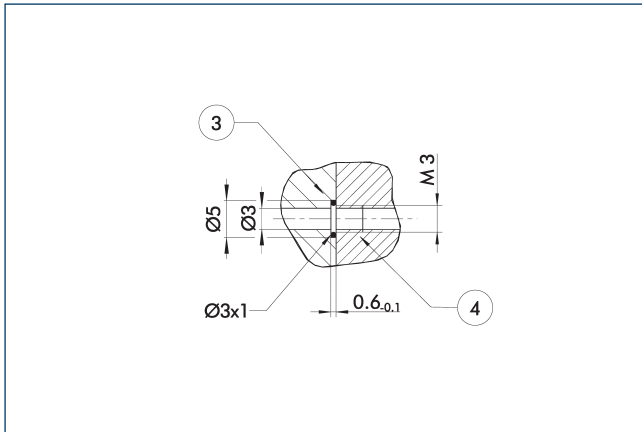

③ Adapter

④ Grippers

The direct connection is used for supplying compressed air without hoses. Instead, the pressure medium is fed through bore-holes in the mounting plate.

Gripping force maintenance version AS/IS

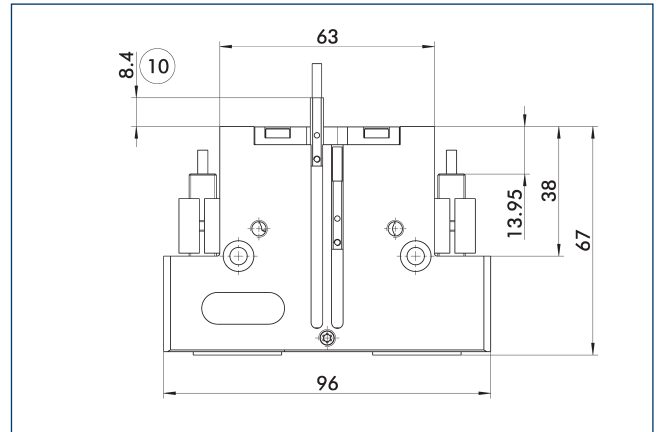

⑩ Projection applies only for AS version

The mechanical gripping force maintenance device ensures that a minimum clamping force will be applied even if there is a drop in pressure. In the AS/S variant this acts as a closing force, in the IS variant as an opening force. Besides this, gripping force maintenance can be used to increase gripping force or for single actuated gripping.

Dustproof version

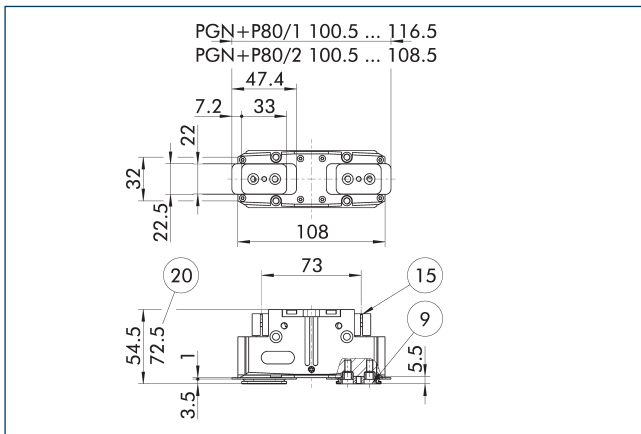

- ⑨ For mounting screw connection ⑮ Sealing bolt
 diagram, see basic version ⑳ For version AS/IS

The "dustproof" option increases the degree of protection against penetrating substances. The assembly diagram shifts by the height of the intermediate jaw. The finger length is still measured from the upper edge of the gripper housing.

Description	ID
Dust cover	
SAD PGN-plus-P 80	1347484

- ① The "dustproof" option can either be ordered as a pre-mounted gripper version or can be retrofitted to the gripper using the "SAD PGN-plus-P" retrofit kit.

Precision version

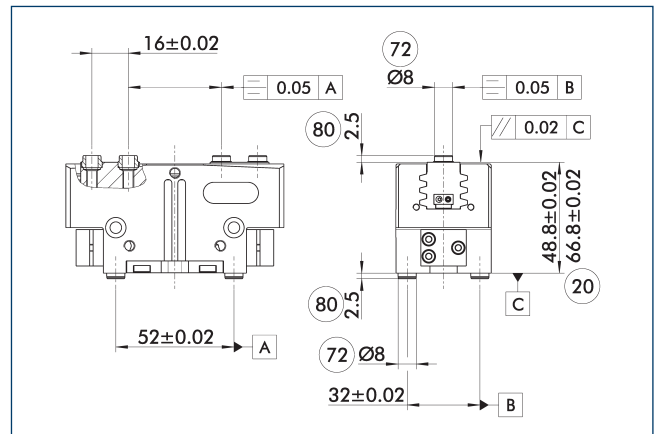

- ⑳ For version AS/IS ⑧① Depth of the centering sleeve
 ⑦② Fit for centering sleeves hole in the counter part

The indicated tolerances just refer to the variants of precision versions shown in the chart of technical specifications. All other variants of precision versions are available on request.

PGN-plus-P 80

Universal gripper

SDV-P pressure maintenance valve

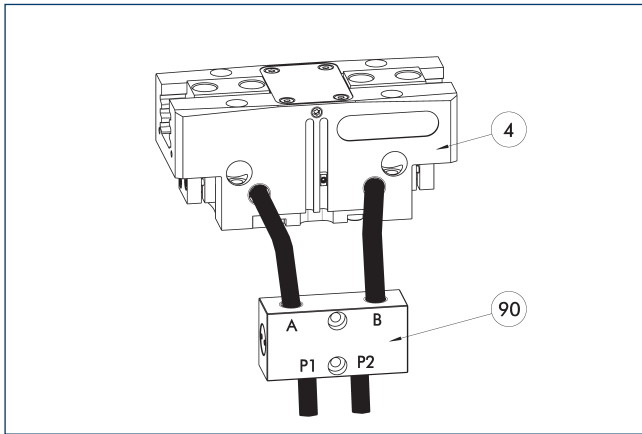

- ④ Grippers
- ⑨⑩ SDV-P pressure maintenance valve

The SDV-P pressure maintenance valve ensures in emergency STOP situations that the pressure in the piston chamber of pneumatic gripper, swivel, linear, and quick-change modules is temporarily maintained.

Description	ID	Recommended hose diameter [mm]
Pressure maintenance valve		
SDV-P 04	0403130	6
SDV-P 07	0403131	8
Pressure maintenance valve with air bleed screw		
SDV-P 04-E	0300120	6
SDV-P 07-E	0300121	8

- ① In order to achieve the specified closing and opening time for each gripper variant, the recommended hose diameter must be used. The direct allocation of the respective variant of the gripper for the respective SDV-P can be found at schunk.com.

SDV-P E-P pressure maintenance valve

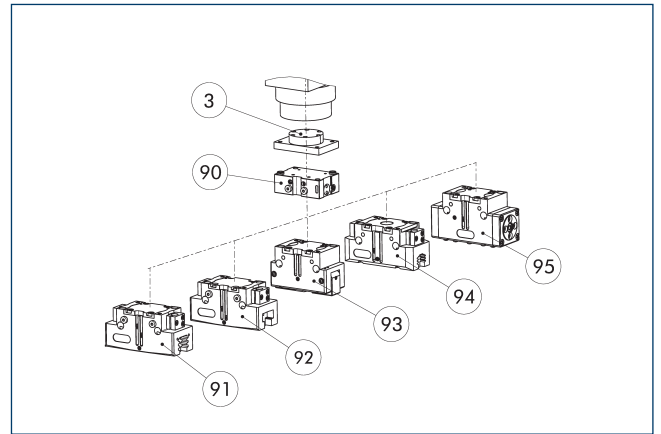

- ③ Adapter
- ⑨⑩ SDV-P E-P pressure maintenance valve
- ⑨① 2-finger parallel gripper
- ⑨② 2-finger parallel gripper JGP-P
- ⑨③ 2-finger angular gripper PWG-plus
- ⑨④ 2-finger parallel gripper PGB PGN-plus/PGN-plus-P
- ⑨⑤ Sealed DPG-plus gripper

The SDV-P E-P pressure maintenance valves ensure that the pressure in the piston chamber is maintained temporarily during an emergency stop. SDV-P E-P can be directly connected to the listed grippers without the need for additional pneumatic hoses.

Description	ID	
Pressure maintenance valve		
SDV-P 80-E-P	0300125	

Protective cover HUE PGN-plus 80

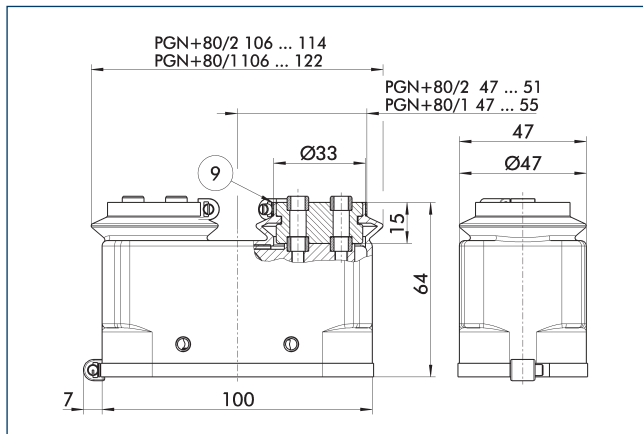

⑨ For mounting screw connection diagram, see basic version

The HUE protective cover fully protects the gripper against external influences. The cover is suitable for applications of up to IP65 if an additional sealing of the cover bottom is provided. For detailed information, please see the HUE series. The connection diagram shifts by the height of the intermediate jaw.

Description	ID	IP protection class
Protection cover		
HUE PGN-plus 80	0371481	65

⑩ The HUE protective cover is not suitable for use on grippers with gripping force maintenance. An inductive monitoring of the gripper in connection with the HUE protective cover is not possible. SCHUNK recommends the use of magnetic sensors that are approved for the respective gripper variant.

BSWS jaw quick-change jaw systems

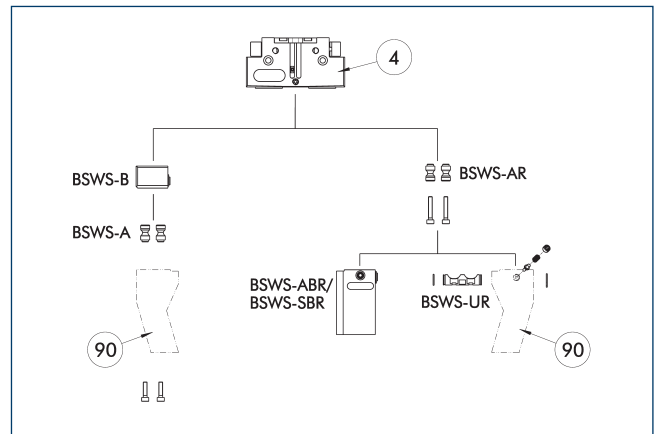

④ Grippers

⑨ Customized gripper fingers

There are various jaw quick-change systems available for the gripper. For detailed information, please refer to the corresponding product.

Description	ID	Scope of delivery
Jaw quick-change system adapter pin		
BSWS-A 80	0303024	2
BSWS-AR 80	0300093	2
Quick-change jaw system base		
BSWS-B 80	0303025	1
Jaw quick-change system finger blank		
BSWS-ABR-PGZN-plus 80	0300073	1
BSWS-SBR-PGZN-plus 80	0300083	1
Jaw quick-change system locking mechanism		
BSWS-UR 80	0302992	1

⑪ If the operating pressure is higher than 6 bar, suitability for use beyond the application limits must be checked. Only systems that are listed in the table, can be used.

Fields of application

Series	Size	Variant	Suitability
PGN-plus-P	80	-1 (6 bar)	■■■■■
PGN-plus-P	80	-1-AS/1-IS (6 bar)	■■■■■
PGN-plus-P	80	-2 (6 bar)	■■■■■
PGN-plus-P	80	-2-AS/2-IS (6 bar)	■■■■■
Legend			
■■■■■	Can be combined without restrictions		
■■□□	Use with restrictions (see loading limits)		
□□□□	cannot be combined		

The load limits for describing the application limits can be found in the catalog chapter of the corresponding accessories.

PGN-plus-P 80

Universal gripper

Jaw quick-change system BSWs-M

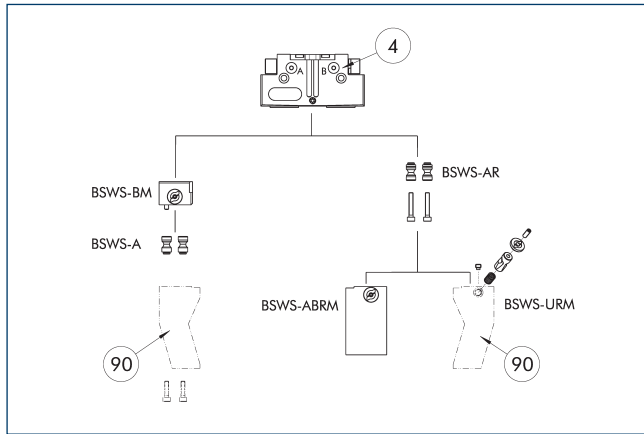

- ④ Grippers
- ⑨⑩ Customized gripper fingers

There are various jaw quick-change systems available for the gripper. For detailed information, please refer to the corresponding product.

Description	ID	Scope of delivery
Jaw quick-change system adapter pin		
BSWS-A 80	0303024	2
BSWS-AR 80	0300093	2
Quick-change jaw system base		
BSWS-BM 80	1313901	1
Jaw quick-change system finger blank		
BSWS-ABRM-PGZN-plus 80	1420852	1
Jaw quick-change system locking mechanism		
BSWS-URM 80	1398402	1

① If the operating pressure is higher than 6 bar, suitability for use beyond the application limits must be checked. Only systems that are listed in the table, can be used.

Fields of application

Series	Size	Variant	Suitability
PGN-plus-P	80	-1 (6 bar)	■■■■■
PGN-plus-P	80	-1-AS/1-IS (6 bar)	■■■■■
PGN-plus-P	80	-2 (6 bar)	■■■■■
PGN-plus-P	80	-2-AS/2-IS (6 bar)	■■■■■
Legend			
■■■■■	Can be combined without restrictions		
■■■□□	Use with restrictions (see loading limits)		
□□□□□	cannot be combined		

The load limits for describing the application limits can be found in the catalog chapter of the corresponding accessories.

ZBA-L-plus 80 intermediate jaws

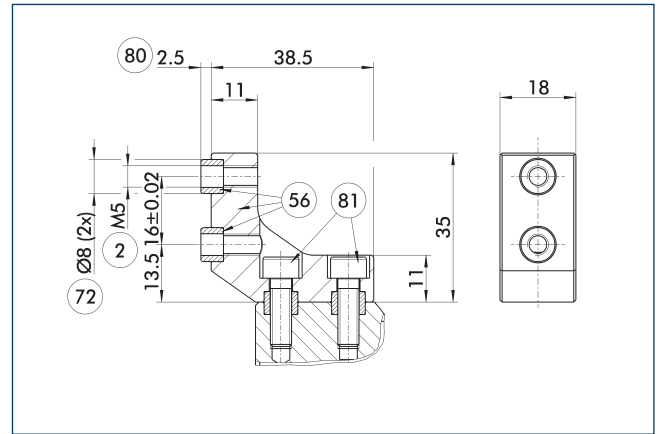

- ② Finger connection
- ⑤⑥ Included in the scope of delivery
- ⑦② Fit for centering sleeves
- ⑧⑩ Depth of the centering sleeve hole in the counter part
- ⑧① Not included in the scope of delivery

The optional ZBA-L-plus intermediate jaws allow the screw connection diagram of the top jaws to be rotated by 90°. This makes it easier to design and produce top jaws (particularly for long versions) because no deep through-bores are required.

Description	ID	Material	Finger interface	Scope of delivery
Intermediate jaw				
ZBA-L-plus 80	0311732	Aluminum	PGN-plus 80	1

UZB 80 universal intermediate jaw

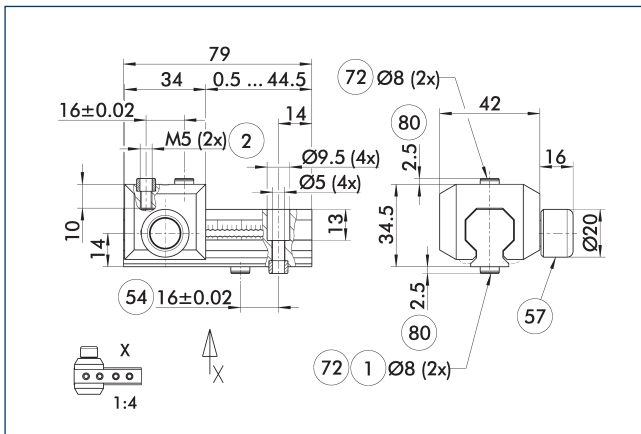

- ① Gripper connection
- ② Finger connection
- ⑤4 Optional right or left connection
- ⑤7 Locking
- ⑦2 Fit for centering sleeves
- ⑧0 Depth of the centering sleeve hole in the counter part

The drawing shows the UZB universal intermediate jaw. The fully removable UZB-S slide (can also be ordered separately) allows for a quick jaw change.

Description	ID	Grid dimension
		[mm]
Universal intermediate jaw		
UZB 80	0300043	2
Finger blank		
ABR-PGZN-plus 80	0300011	
SBR-PGZN-plus 80	0300021	
Slide for universal intermediate jaw		
UZB-S 80	5518271	2

- ① If the operating pressure is higher than 6 bar, suitability for use beyond the application limits must be checked.

Fields of application

Series	Size	Variant	Suitability
PGN-plus-P	80	-1 (6 bar)	■■■■■
PGN-plus-P	80	-1-AS/1-IS (6 bar)	■■■□□
PGN-plus-P	80	-2 (6 bar)	■■■□□
PGN-plus-P	80	-2-AS/2-IS (6 bar)	□□□□
Legend			
■■■■■	Can be combined without restrictions		
■■■□□	Use with restrictions (see loading limits)		
□□□□	cannot be combined		

The load limits for describing the application limits can be found in the catalog chapter of the corresponding accessories.

Finger blanks ABR/SBR-PGZN-plus 80

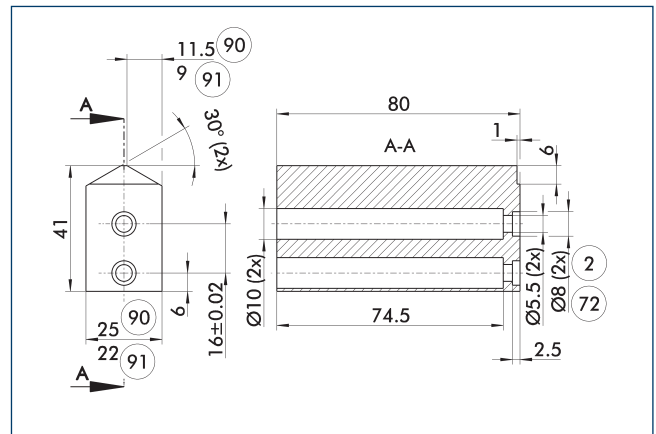

- ② Finger connection
- ⑦2 Fit for centering sleeves
- ⑨0 ABR-PGZN-plus
- ⑨1 SBR-PGZN-plus

The drawing shows the finger blank which can be reworked by the customer.

Description	ID	Material	Scope of delivery
Finger blank			
ABR-PGZN-plus 80	0300011	Aluminum (3.4365)	1
SBR-PGZN-plus 80	0300021	Steel (1.7131)	1

- ① In the PGL-plus-P gripper series, the use of finger blanks results in a limitation of the closing stroke. Please check this in detail in advance using the CAD data and adjust the reworking of the fingers accordingly.

PGN-plus-P 80

Universal gripper

Tolerance compensation unit TCU

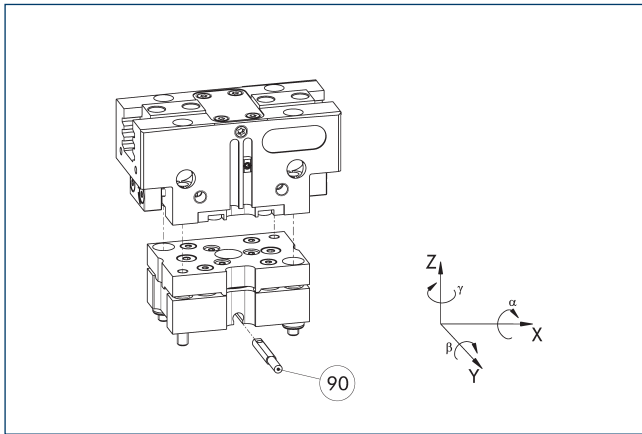

90 Monitoring of locking

Grippers can be directly mounted without an adapter plate. Tolerance compensation unit and gripper have an identical screw connection diagram. Therefore the tolerance compensation units can be assembled later. Please consider the additional assembly height of the tolerance compensation unit. For details please refer to our catalog robot accessories.

Description	ID	Locking	Deflection	Often combined
Compensation unit				
TCU-P-080-3-MV	0324792	yes	$\pm 1^\circ / \pm 1,5^\circ / \pm 2^\circ$	●
TCU-P-080-3-OV	0324793	no	$\pm 1^\circ / \pm 1,5^\circ / \pm 2^\circ$	

Compensation unit AGE-F

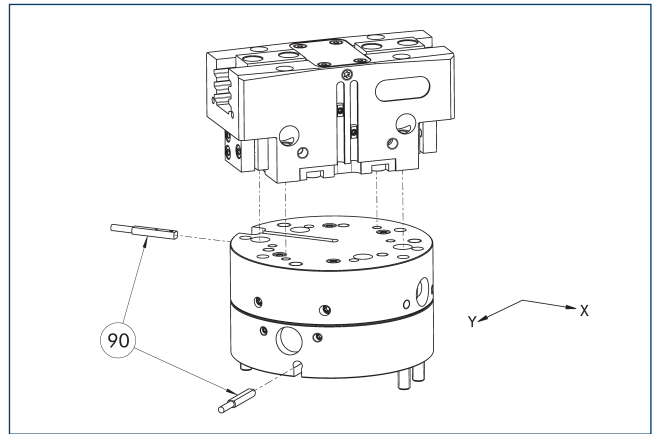

90 Monitoring

The unit has direct connection possibilities for different grippers of the PGN-plus, PGN-plus-P and PZN-plus series. For more detailed information, please refer to the main view.

Description	ID	Compensation XY [mm]	Reset force [N]	Often combined
Compensation unit				
AGE-F-XY-063-1	0324940	± 4	12	
AGE-F-XY-063-2	0324941	± 4	16	
AGE-F-XY-063-3	0324942	± 4	20	●

① Due to the interfering contour, monitoring of the gripper is not possible.

Adapter plate PGN-plus 80

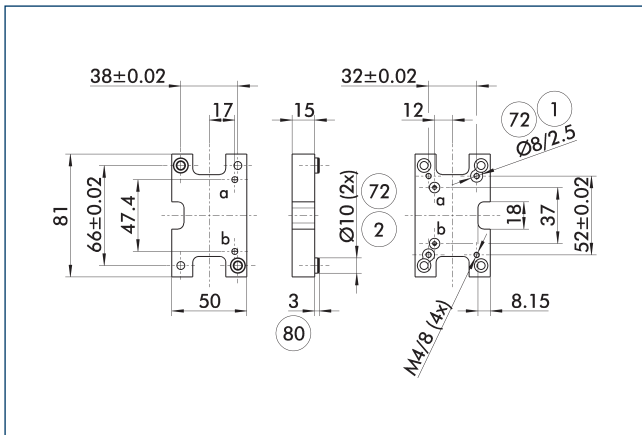

- ① Robot-side connection
- ② Tool-side connection
- 72 Fit for centering sleeves
- 80 Depth of the centering sleeve hole in the counter part

The adapter plate has integrated air feed-throughs in order to be able to use the hose-free direct connection of the appropriate gripper.

Description	ID
Tool side	
A-CWA-100-080-P	0305804

Compact change system for grippers

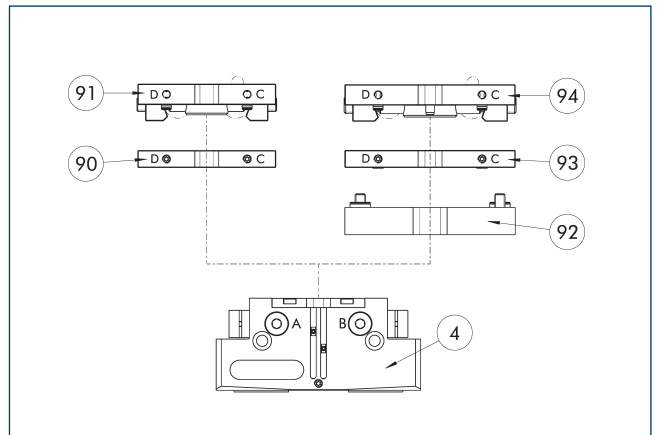

- ④ Grippers
- 90 CWA compact change adapter
- 91 CWK compact change master
- 92 A-CWA adapter plate
- 93 CWA compact change adapter
- 94 CWK compact change master

Grippers can be directly mounted without an adapter plate. For details see our catalog Gripping or Robot Accessories.

Description	ID
Tool side	
A-CWA-100-080-P	0305804
CWA compact change adapter	
CWA-080-P	0305781
CWK compact change master	
CWK-080-P	0305780

Add-on valves for single grippers

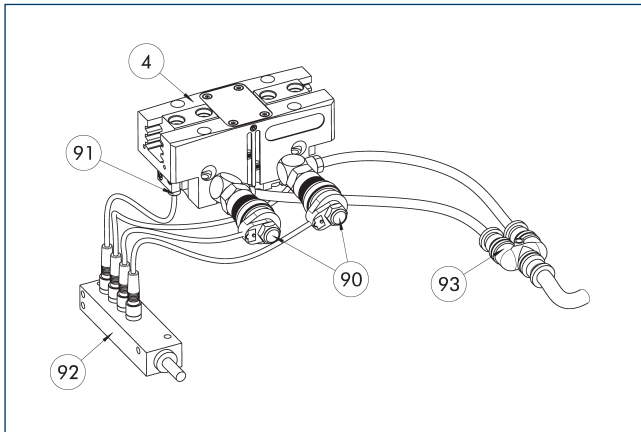

- ④ Grippers
- ⑨① Sensor
- ⑨② Sensor distributor
- ⑨③ Y distributor
- ⑨② Micro valves

The set of attachment valves reduces the compressed air consumption as there is no need to ventilate or bleed the supply lines. This can also reduce cycle time. The hose-free direct assembly of the micro valves reduces the hosing effort for the gripper. To further simplify electrical connection of the valves and sensors, their signals can be bundled via an optional distributor.

Description	ID	Often combined
Add-on valve set		
ABV-MV25-M5	0303326	
ABV-MV25-M5-V2-M8	0303392	
ABV-MV25-M5-V4-M8	0303362	●

- ① A set of add-on valves ABV is required per actuator. The ABV set contains two 3/2 micro valves, an Y-distributor for compressed air supply and optionally a sensor distributor with two or four inputs or outputs. Sensors for monitoring the gripper need to be ordered separately. Pneumatic hoses are not included in the scope of delivery.

Add-on valves for double grippers

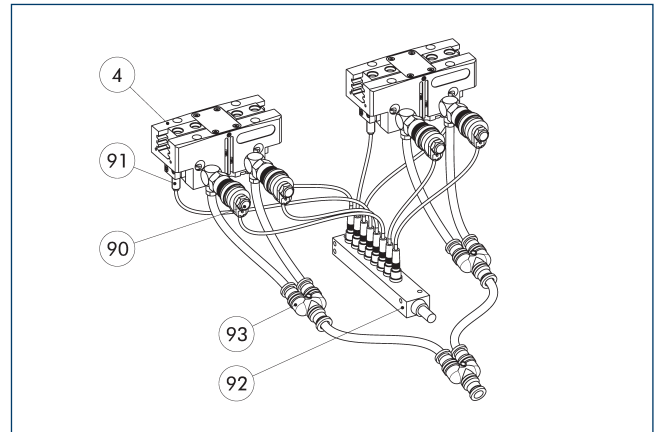

- ④ Grippers
- ⑨① Sensor
- ⑨② Sensor distributor
- ⑨③ Y distributor
- ⑨② Micro valves

The add-on valve set reduces compressed air consumption as there is no need to ventilate or bleed the supply lines. This can also reduce cycle time. The hose-free direct assembly of the micro valves reduces the hosing effort for the gripper. To further simplify electrical connection of the valves and sensors, their signals can be bundled via a distributor.

Description	ID	
Add-on valve set		
ABV-MV25-M5-V8-M8	0303363	

- ① A set of add-on valves ABV is required per double gripping unit. The ABV set contains four 3/2 microvalves, three Y-distributors for compressed air supply and a sensor distributor with eight inputs or outputs. Sensors for monitoring the gripper need to be ordered separately. Pneumatic hoses are not included in the scope of delivery.

Modular Assembly Automation

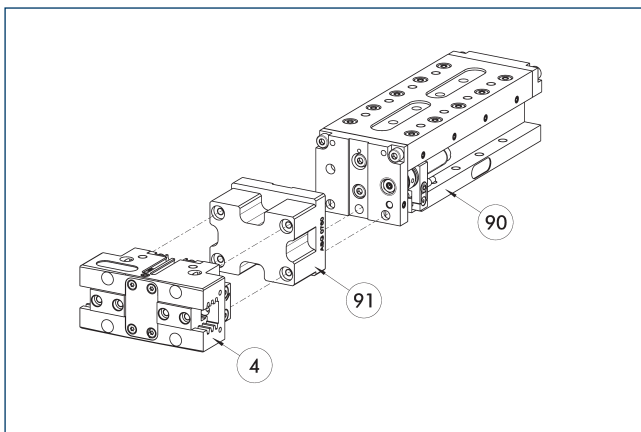

- ④ Grippers
- ⑨① ASG adapter plate
- ⑨② Linear module CLM/KLM/LM/ELP/ELM/ELS/HLM

Grippers and linear modules can be combined with standard adapter plates from the modular assembly system. For more information see our main catalog "Modular Assembly Automation".

PGN-plus-P 80

Universal gripper

Inductive proximity switches

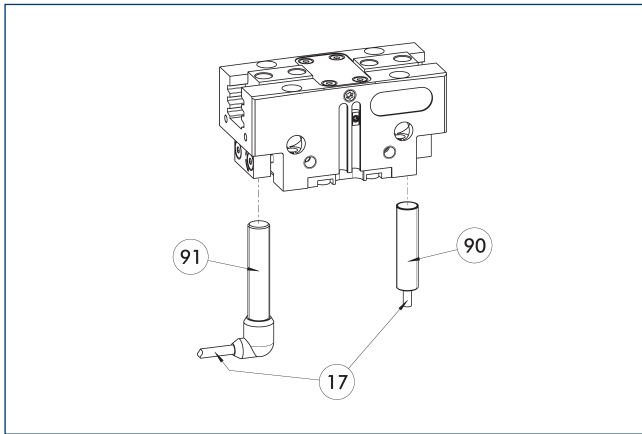

17 Cable outlet

91 Sensor IN..-SA

90 Sensor IN ...

Directly mounted end position monitoring.

Description	ID	Often combined
Inductive proximity switches		
IN 80-S-M12	0301578	
IN 80-S-M8	0301478	●
INK 80-S	0301550	
Inductive proximity switch with lateral cable outlet		
IN 80-S-M12-SA	0301587	
IN 80-S-M8-SA	0301483	●
INK 80-S-SA	0301566	
Connection cables		
KA BG08-L 3P-0300-PNP	0301622	●
KA BG08-L 3P-0500-PNP	0301623	
KA BG12-L 3P-0500-PNP	30016369	
KA BW08-L 3P-0300-PNP	0301594	
KA BW08-L 3P-0500-PNP	0301502	
KA BW12-L 3P-0300-PNP	0301503	
KA BW12-L 3P-0500-PNP	0301507	
Clip for connector/socket		
CLI-M12	0301464	
CLI-M8	0301463	
Cable extension		
KV BG12-SG12 3P-0030-PNP	0301999	
KV BG12-SG12 3P-0060-PNP	0301998	
KV BW08-SG08 3P-0030-PNP	0301495	
KV BW08-SG08 3P-0100-PNP	0301496	
KV BW08-SG08 3P-0200-PNP	0301497	●
KV BW12-SG12 3P-0030-PNP	0301595	
KV BW12-SG12 3P-0100-PNP	0301596	
KV BW12-SG12 3P-0200-PNP	0301597	
Sensor distributor		
V2-M12	0301776	●
V2-M8	0301775	●
V4-M8	0301746	
V8-M8	0301751	

① Two sensors are required per unit for monitoring two positions. On option, extension cables and sensor distributors are available. Additional product variants of the sensor, and further information and technical data can be found in the catalog chapter sensor system.

Flexible position sensor

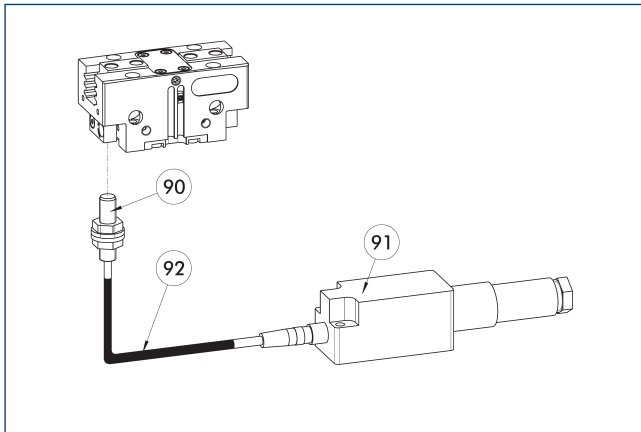

- 90 FPS-S sensor
- 91 FPS-F5 evaluation electronic
- 92 Cable extension

Flexible position monitoring of up to five positions.

Description	ID	
Attachment kit for FPS		
AS-FPS-PGN-plus-P 64/80	1363890	
Sensor		
FPS-S M8	0301704	
Evaluation electronics		
FPS-F5	0301805	
Cable extension		
KV BG08-SG08 3P-0050	0301598	
KV BG08-SG08 3P-0100	0301599	

- ① When using an FPS system, an FPS sensor (FPS-S) as well as an electronic processor (FPS-F5 / F5 T) are required for each gripper as well as a mounting kit (AS), if listed. Cable extensions (KV) are optionally available – see catalog chapter “Accessories.”

Electronic magnetic switch MMS

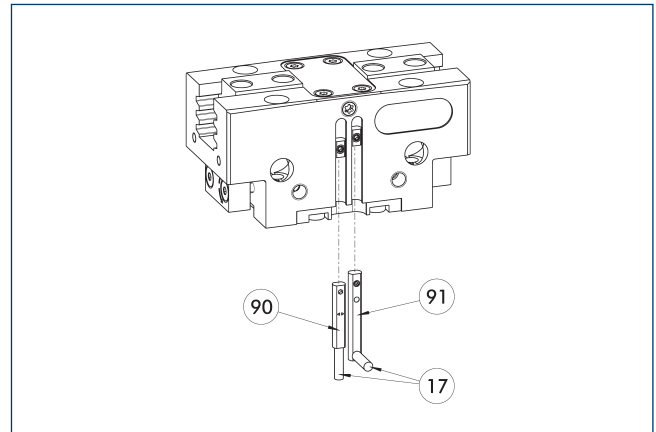

- 17 Cable outlet
- 90 Sensor MMS 22..
- 91 Sensor MMS 22...-SA

End position monitoring for mounting in the C-slot.

Description	ID	Often combined
Electronic magnetic switch		
MMS 22-S-M8-PNP	0301032	●
MMSK 22-S-PNP	0301034	
Electronic magnetic switches with lateral cable outlet		
MMS 22-S-M8-PNP-SA	0301042	●
MMSK 22-S-PNP-SA	0301044	
Connection cables		
KA BG08-L 3P-0300-PNP	0301622	●
KA BG08-L 3P-0500-PNP	0301623	
KA BW08-L 3P-0300-PNP	0301594	
KA BW08-L 3P-0500-PNP	0301502	
Clip for connector/socket		
CLI-M8	0301463	
Cable extension		
KV BW08-SG08 3P-0030-PNP	0301495	
KV BW08-SG08 3P-0100-PNP	0301496	
KV BW08-SG08 3P-0200-PNP	0301497	●
Sensor distributor		
V2-M8	0301775	●
V4-M8	0301746	
V8-M8	0301751	

- ① Two sensors are required per unit for monitoring two positions. On option, extension cables and sensor distributors are available. Additional product variants of the sensor, and further information and technical data can be found in the catalog chapter sensor system.

PGN-plus-P 80

Universal gripper

Programmable magnetic switch MMS 22-PI1

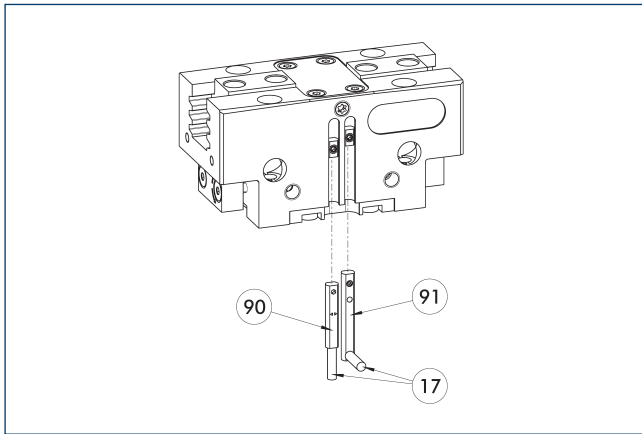

- ①⑦ Cable outlet
- ①⑨ Sensor MMS 22 ..-PI1-...-SA
- ①⑩ Sensor MMS 22 PI1-...

Position monitoring with one programmable position per sensor and integrated electronic system in the sensor. Can be programmed using MT magnetic teaching tool (included in the scope of delivery, ID 0301030) or ST plug teaching tool (optional). End position monitoring for mounting in the C-slot. If the ST plug teaching tools are listed in the table provided, teaching is only possible with the ST teaching tools.

Description	ID	Often combined
Programmable magnetic switch		
MMS 22-PI1-S-M8-PNP	0301160	●
MMSK 22-PI1-S-PNP	0301162	
Programmable magnetic switch with lateral cable outlet		
MMS 22-PI1-S-M8-PNP-SA	0301166	●
MMSK 22-PI1-S-PNP-SA	0301168	
Programmable magnetic switch with stainless steel housing		
MMS 22-PI1-S-M8-PNP-HD	0301110	●
MMSK 22-PI1-S-PNP-HD	0301112	

- ① Two sensors are required per unit for monitoring two positions. On option, extension cables and sensor distributors are available. Additional product variants of the sensor, and further information and technical data can be found in the catalog chapter sensor system.

Programmable magnetic switch MMS 22-PI2

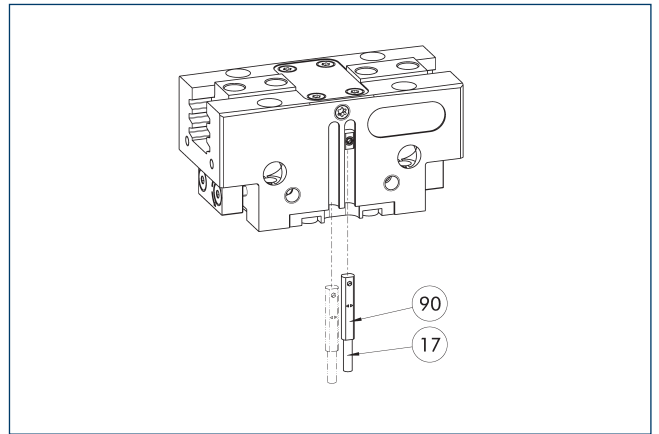

- ①⑦ Cable outlet
- ①⑩ MMS 22...-PI2-... sensor

Position monitoring with two programmable positions per sensor and electronics integrated in the sensor. Can be programmed using MT magnetic teaching tool (included in the scope of delivery, ID 0301030) or ST plug teaching tool (optional). End position monitoring for mounting in the C-slot. If the ST plug teaching tools are listed in the table provided, teaching is only possible with the ST teaching tools.

Description	ID	Often combined
Programmable magnetic switch		
MMS 22-PI2-S-M8-PNP	0301180	●
MMSK 22-PI2-S-PNP	0301182	
Programmable magnetic switch with lateral cable outlet		
MMS 22-PI2-S-M8-PNP-SA	0301186	●
MMSK 22-PI2-S-PNP-SA	0301188	
Programmable magnetic switch with stainless steel housing		
MMS 22-PI2-S-M8-PNP-HD	0301130	●
MMSK 22-PI2-S-PNP-HD	0301132	

- ① One sensor is required per unit for monitoring two positions. Extension cables and sensor distributors are optionally available. Additional product variants of the sensor, and further information and technical data can be found in the catalog chapter sensor systems.

MMS-P programmable magnetic switch

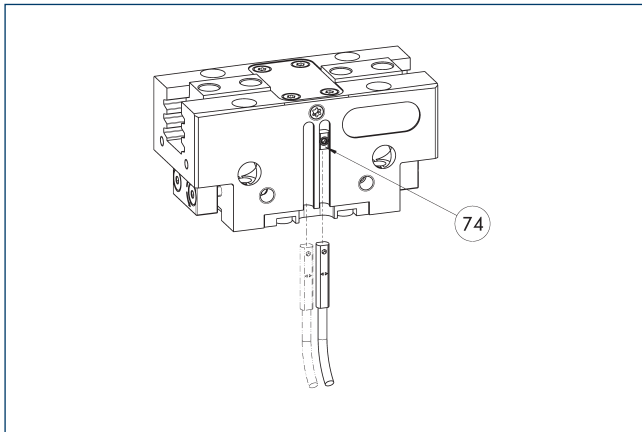

74 Limit stop for sensor

Position monitoring with two programmable positions per sensor. End position monitoring for mounting in the C-slot.

Description	ID	Often combined
Programmable magnetic switch		
MMSK-P 22-S-PNP	0301371	
MMS-P 22-S-M8-PNP	0301370	●
Connection cables		
KA GLN0804-LK-00500-A	0307767	●
KA GLN0804-LK-01000-A	0307768	
KA WLN0804-LK-00500-A	0307765	
KA WLN0804-LK-01000-A	0307766	
Clip for connector/socket		
CLI-M8	0301463	
Sensor distributor		
V2-M8-4P-2XM8-3P	0301380	

① One sensor is required per unit for monitoring two positions. Extension cables and sensor distributors are optionally available. Additional product variants of the sensor, and further information and technical data can be found in the catalog chapter sensor systems.

Analog position sensor MMS-A

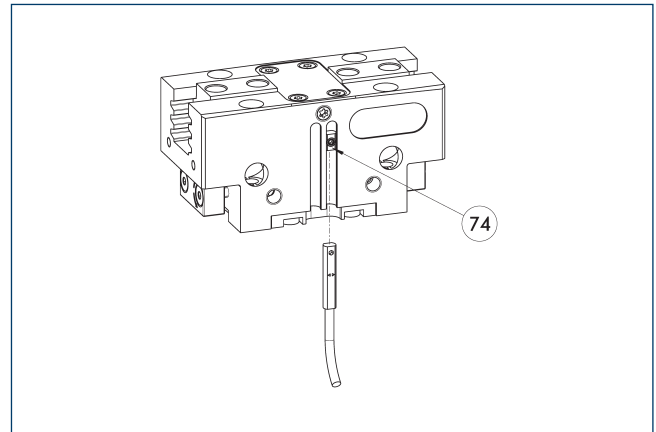

74 Limit stop for sensor

Non-contact measuring, analog multi-position monitoring for any number of positions, easy to assemble in the C-slot. Can be programmed using MT magnetic teaching tool (included in the scope of delivery, ID 0301030) or ST plug teaching tool (optional). End position monitoring for mounting in the C-slot. If the ST plug teaching tools are listed in the chart provided, teaching is only possible with the ST teaching tools.

Description	ID	
Analog position sensor		
MMS 22-A-10V-M08	0315825	
MMS 22-A-10V-M12	0315828	

① One sensor is required for each gripper. No additional mounting kit is required – the gripper is equipped for use of the sensor by default. Further information and technical data can be found in the catalog chapter sensor systems.

PGN-plus-P 80

Universal gripper

Flexible position sensor with MMS-A

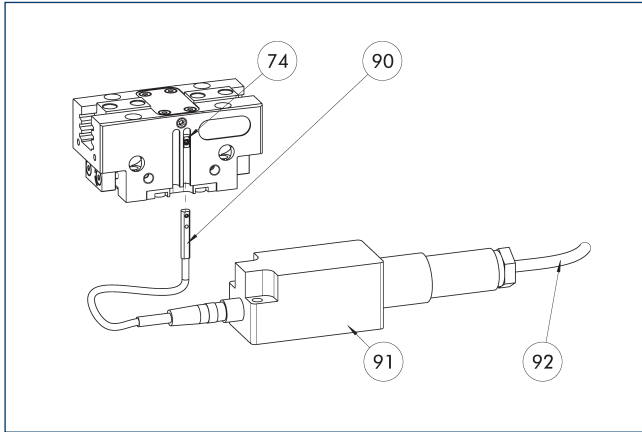

- ⑦④ Limit stop for sensor
- ⑨① FPS-F5 evaluation electronic
- ⑨② MMS 22-A-... sensor
- ⑨② Connection cables

Flexible position monitoring of up to five positions. Sensor can be taught using MT magnetic teaching tool (included in the scope of delivery, ID 0301030) or ST plug teaching tool (optional). If the ST plug teaching tools are listed in the table provided, teaching is only possible with the ST teaching tools.

Description	ID	
Analog position sensor		
MMS 22-A-05V-M08	0315805	
Evaluation electronics		
FPS-F5	0301805	
Sensor Teaching Tool		
MT-MMS 22-PI	0301030	
Connection cables		
KA BG16-L 12P-1000	0301801	

- ① When using an FPS system, one MMS 22-A-05V and one evaluation electronics (FPS-F5) are required per each gripper, as well as an attachment kit (AS), if listed. On option, cable extensions (KV) are available – see catalog chapter “Accessories.”

Programmable magnetic switch MMS-IO-Link

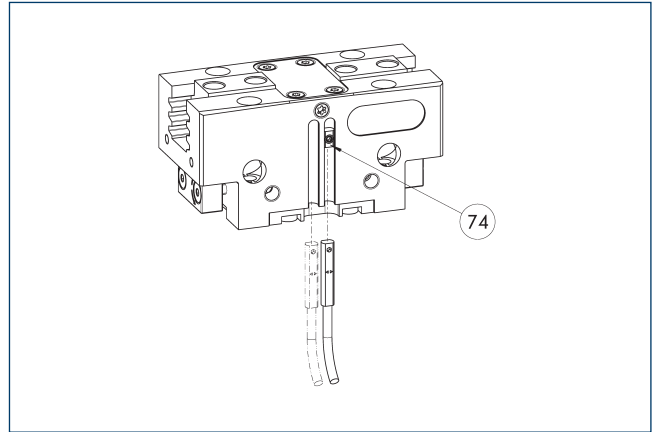

- ⑦④ Limit stop for sensor

Sensor for multi-position monitoring through detection of the complete gripper stroke. The sensor is mounted directly in the C-slot of the gripper. The sensor is programmed for the gripper via the IO-Link interface, Magnet teaching tool MT (included in scope of delivery; ID 0301030) or the ST plug teaching tool (not included in scope of delivery; ID 0301026). An IO-Link master is required for operation.

Description	ID	
Programmable magnetic switch		
MMS 22-IO-L-M08	0315830	
MMS 22-IO-L-M12	0315835	

- ① One sensor is required for each gripper. No additional mounting kit is required – the gripper is equipped for use of the sensor by default. Further information and technical data can be found in the catalog chapter sensor systems.

APS-Z80 analog position sensor

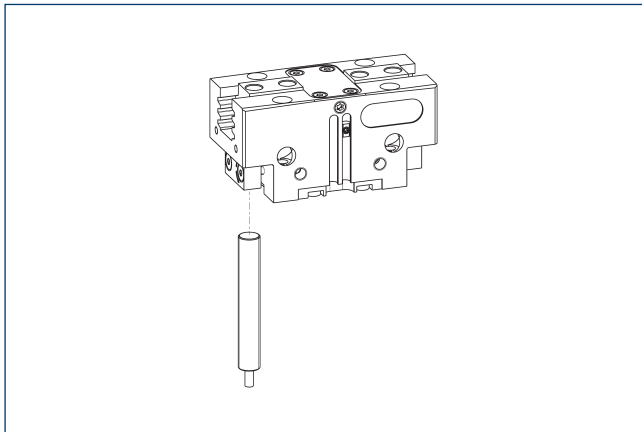

Non-contact measuring, analog multi-position monitoring for any number of positions.

Description	ID	Often combined
Mounting kit for APS-Z80		
AS-APS-Z80-PGN-plus-P 80-1	1366209	
AS-APS-Z80-PGN-plus-P 80-2	1366215	
Analog position sensor		
APS-Z80-K	0302072	
APS-Z80-M8	0302070	●

- ① When using an APS system, one mounting kit (AS-APS-Z80) and one APS-Z80 sensor is required per gripper. The resolution of the sensor can be lower in the peripheral areas of the gripper. You can find further information on the product in the operating manual.

APS-M1 analog position sensor

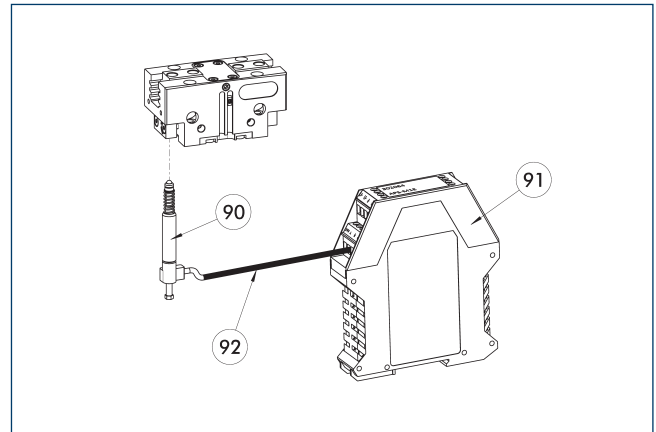

- ⑨⑩ APS-M1S sensor ⑨② APS-K extension cable
 ⑨① APS-M1E electronic processor

Analog multi position monitoring for any desired positions

Description	ID	
Mounting kit for APS-M1		
AS-APS-M1-PGN-plus-P 80-1	1363725	
AS-APS-M1-PGN-plus-P 80-2	1363731	
Analog position sensor		
APS-M1S	0302062	
Connection cables		
APS-K0200	0302066	
APS-K0700	0302068	
Evaluation electronics		
APS-M1E	0302064	

- ① When using an APS system, for each gripper an attachment kit (AS-APS-M1), an APS-M1S sensor (incl. 3 m cable) as well as an electronics (APS-M1e) are required. An extension cable (APS-K) can be connected between the sensor and the electronics as an option. The max. cable length between the sensor and the electronics is 10 m, between the electronics and their control unit (PLC) it is max. 1 m.

PGN-plus-P 100

Universal gripper



Gripping force O.D. gripping

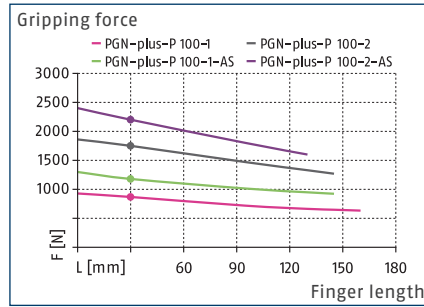

Gripping force I.D. gripping

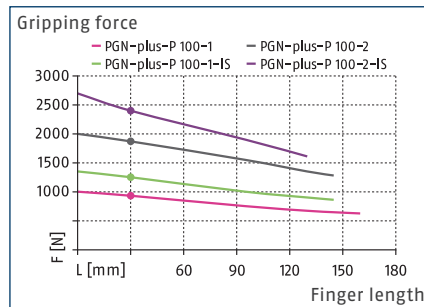

Dimensions and maximum loads

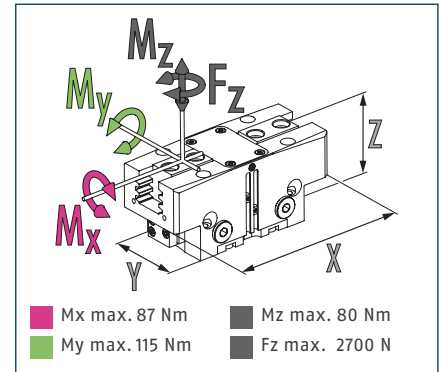

① The indicated moments and forces are static values, apply for each base jaw and may appear simultaneously. Loads may additionally occur to the moment produced by the gripping force itself.

Technical data

Description		PGN-plus-P 100-1	PGN-plus-P 100-2	PGN-plus-P 100-1-AS	PGN-plus-P 100-2-AS	PGN-plus-P 100-1-IS	PGN-plus-P 100-2-IS
ID		0318544	0318545	0318546	0318547	0318548	0318549
Stroke per jaw	[mm]	10	5	10	5	10	5
Closing/opening force	[N]	870/930	1750/1870	1180/-	2200/-	-/1250	-/2400
Min. spring force	[N]			310	450	320	530
Weight	[kg]	0.9	0.9	1.1	1.1	1.1	1.1
Recommended workpiece weight	[kg]	4.35	8.75	4.35	8.75	4.35	8.75
Fluid consumption double stroke	[cm ³]	55	55	84	84	92	92
Min./nom./max. operating pressure	[bar]	2.5/6/8	2.5/6/8	4/6/6.5	4/6/6.5	4/6/6.5	4/6/6.5
Min./max. air purge pressure	[bar]	0.5/1	0.5/1	0.5/1	0.5/1	0.5/1	0.5/1
Closing/opening time	[s]	0.06/0.06	0.06/0.06	0.05/0.09	0.05/0.09	0.09/0.05	0.09/0.05
Closing/opening time with spring	[s]			0.10	0.10	0.10	0.10
Max. permissible finger length	[mm]	160	145	145	130	145	130
Max. permissible weight per finger	[kg]	1.3	1.3	1.3	1.3	1.3	1.3
IP protection class		40	40	40	40	40	40
Min./max. ambient temperature	[°C]	5/90	5/90	5/90	5/90	5/90	5/90
Repeat accuracy	[mm]	0.01	0.01	0.01	0.01	0.01	0.01
Dimensions X x Y x Z	[mm]	120 x 50 x 55	120 x 50 x 55	120 x 50 x 81	120 x 50 x 81	120 x 50 x 81	120 x 50 x 81
Options and their characteristics							
Dustproof version		1317570	1317571	1317572	1317574	1317578	1317581
IP protection class		64	64	64	64	64	64
Weight	[kg]	1.02	1.02	1.22	1.22	1.22	1.22
Corrosion-protected version		38318544	38318545	38318546	38318547	38318548	38318549
High-temperature version		39318544	39318545	39318546	39318547	39318548	39318549
Min./max. ambient temperature	[°C]	5/130	5/130	5/130	5/130	5/130	5/130
Precision version		0318550	0318551	0318552	0318553		
H1 grease version		1353820	1475855	1353821	1431141	1353822	1475926
Dustproof/H1 grease version		1475854	1475856	1475857	1475858	1475925	1475928
Weight	[kg]	1.02	1.02	1.22	1.22	1.22	1.22
IP protection class		64	64	64	64	64	64

① It may take a few 100 gripping cycles until the full gripping force (as indicated in the data table) will be available.

Main view

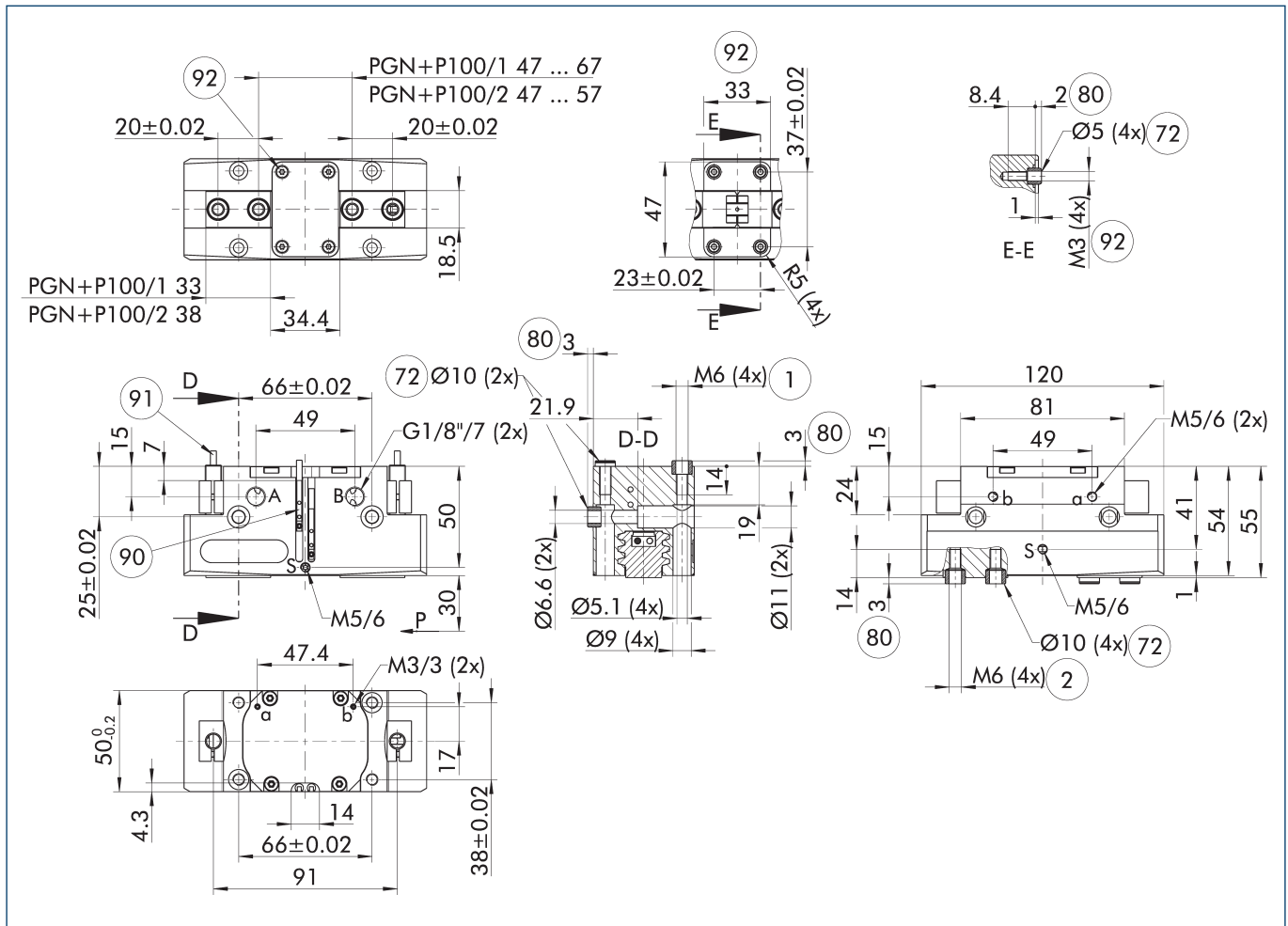

The drawing shows the gripper in the basic version with closed jaws, without dimensional consideration of the options described below.

① As an alternative/in addition to spring-assisted mechanical gripping force maintenance, the SDV-P pressure maintenance valve can be used for I.D. and O.D. gripping (see "Accessories" section of catalog).

- A, a Main / direct connection, gripper opening
- B, b Main / direct connection, gripper closing
- S Air purge connection
- ① Gripper connection
- ② Finger connection
- ⑦ Fit for centering sleeves

- ⑧ Depth of the centering sleeve hole in the counter part
- ⑨ Sensor MMS 22..
- ⑩ Sensor IN ...
- ⑨ Screw connection with centering for customized mounting (these centering sleeves are not included in the scope of delivery)

PGN-plus-P 100

Universal gripper

Maximum permitted finger projection

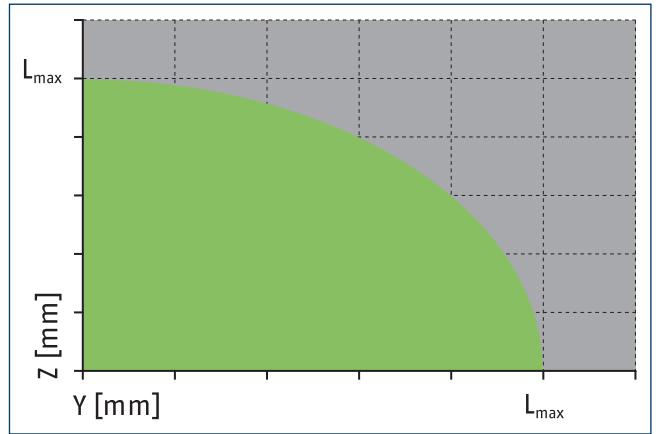
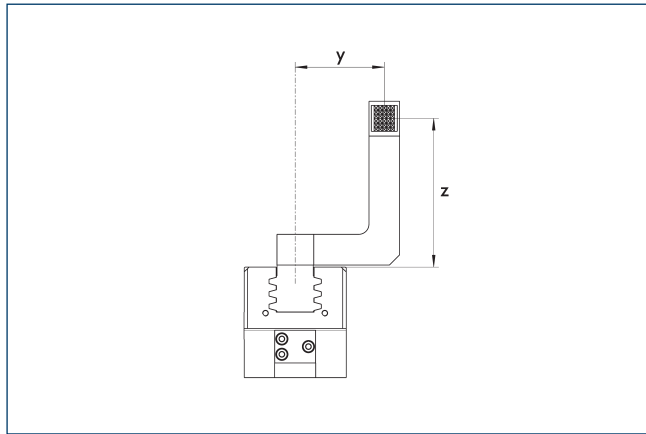

■ Permitted range ■ Inadmissible range

L^{max} is equivalent to the maximum permitted finger length, see the technical data table.

Hose-free direct connection M3

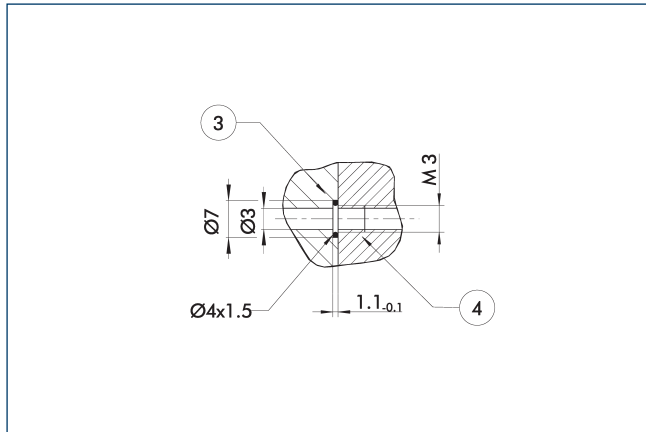

③ Adapter

④ Grippers

The direct connection is used for supplying compressed air without hoses. Instead, the pressure medium is fed through bore-holes in the mounting plate.

Gripping force maintenance version AS/IS

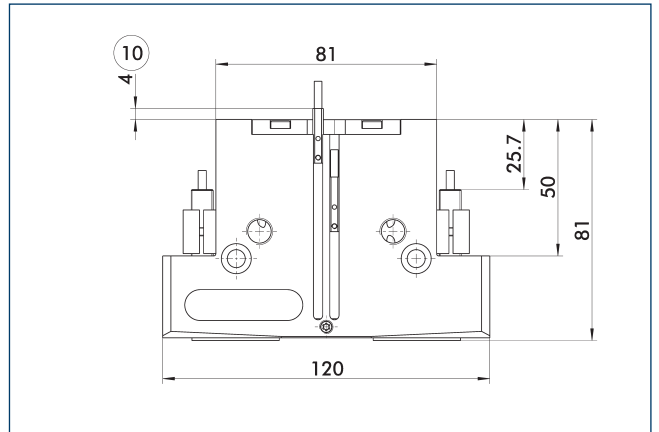

⑩ Projection applies only for AS version

The mechanical gripping force maintenance device ensures that a minimum clamping force will be applied even if there is a drop in pressure. In the AS/S variant this acts as a closing force, in the IS variant as an opening force. Besides this, gripping force maintenance can be used to increase gripping force or for single actuated gripping.

PGN-plus-P 100

Universal gripper

SDV-P pressure maintenance valve

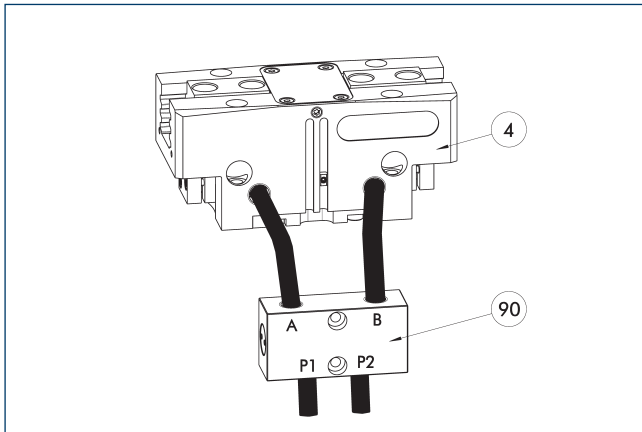

- ④ Grippers
- ⑨⑩ SDV-P pressure maintenance valve

The SDV-P pressure maintenance valve ensures in emergency STOP situations that the pressure in the piston chamber of pneumatic gripper, swivel, linear, and quick-change modules is temporarily maintained.

Description	ID	Recommended hose diameter [mm]
Pressure maintenance valve		
SDV-P 04	0403130	6
SDV-P 07	0403131	8
Pressure maintenance valve with air bleed screw		
SDV-P 04-E	0300120	6
SDV-P 07-E	0300121	8

- ① In order to achieve the specified closing and opening time for each gripper variant, the recommended hose diameter must be used. The direct allocation of the respective variant of the gripper for the respective SDV-P can be found at schunk.com.

SDV-P E-P pressure maintenance valve

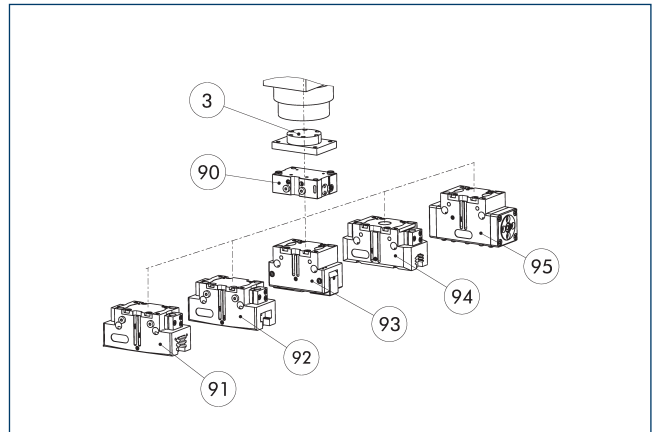

- ③ Adapter
- ⑨⑩ SDV-P E-P pressure maintenance valve
- ⑨① 2-finger parallel gripper PGN-plus/PGN-plus-P
- ⑨② 2-finger parallel gripper JGP-P
- ⑨③ 2-finger angular gripper PWG-plus
- ⑨④ 2-finger parallel gripper PGB
- ⑨⑤ Sealed DPG-plus gripper

The SDV-P E-P pressure maintenance valves ensure that the pressure in the piston chamber is maintained temporarily during an emergency stop. SDV-P E-P can be directly connected to the listed grippers without the need for additional pneumatic hoses.

Description	ID	
Pressure maintenance valve		
SDV-P 100-E-P	0300126	

Pneumatic positioning device PPD

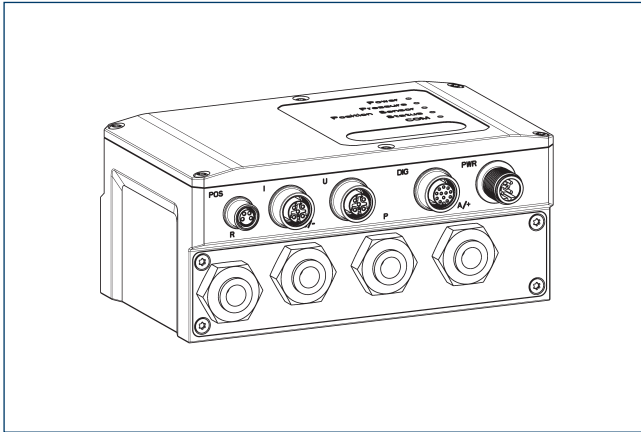

The PPD allows flexibility in all applications with pneumatic grippers through free positioning, gripping force and speed adjustment.

Description	ID	
Pneumatic positioning device		
PPD 20-IOL	1540700	
Adapter		
A GGN0804-1204-A	1540691	
IO-Link connection cable		
KA GGN1205-1212-IOL-00100-A	1540697	
Voltage supply connection cable - cable track compatible		
KA GLN12B05-LK-01000-A	1540660	
Cable extension		
KV GGN0804-I0-00150-A	1540662	
KV GGN0804-I0-00300-A	1540663	
Assembly set		
Assembly set PPD	1540705	

① In addition to the PPD, a position sensor (SCHUNK IO-Link sensor or analog sensor (4...20 mA)) is required.

Protective cover HUE PGN-plus 100

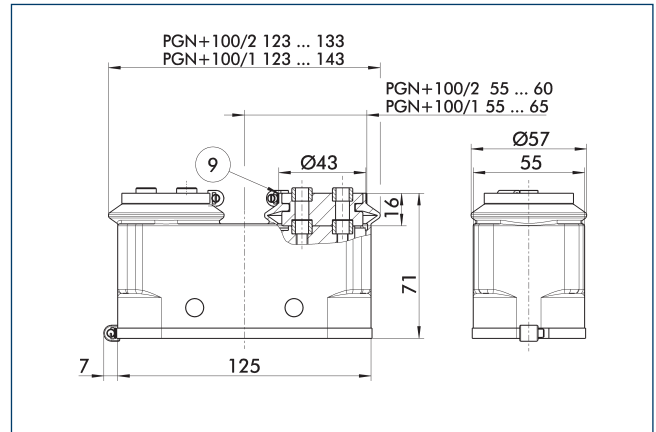

⑨ For mounting screw connection diagram, see basic version

The HUE protective cover fully protects the gripper against external influences. The cover is suitable for applications of up to IP65 if an additional sealing of the cover bottom is provided. For detailed information, please see the HUE series. The connection diagram shifts by the height of the intermediate jaw.

Description	ID	IP protection class
Protection cover		
HUE PGN-plus 100	0371482	65

① The HUE protective cover is not suitable for use on grippers with gripping force maintenance. An inductive monitoring of the gripper in connection with the HUE protective cover is not possible. SCHUNK recommends the use of magnetic sensors that are approved for the respective gripper variant.

PGN-plus-P 100

Universal gripper

BSWS jaw quick-change jaw systems

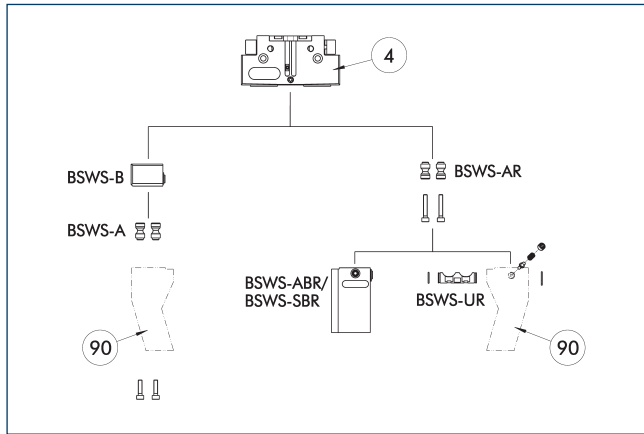

④ Grippers ⑨0 Customized gripper fingers

There are various jaw quick-change systems available for the gripper. For detailed information, please refer to the corresponding product.

Description	ID	Scope of delivery
Jaw quick-change system adapter pin		
BSWS-A 100	0303026	2
BSWS-AR 100	0300094	2
Quick-change jaw system base		
BSWS-B 100	0303027	1
Jaw quick-change system finger blank		
BSWS-ABR-PGZN-plus 100	0300074	1
BSWS-SBR-PGZN-plus 100	0300084	1
Jaw quick-change system locking mechanism		
BSWS-UR 100	0302993	1

① If the operating pressure is higher than 6 bar, suitability for use beyond the application limits must be checked. Only systems that are listed in the table, can be used.

Fields of application

Series	Size	Variant	Suitability
PGN-plus-P	100	-1 (6 bar)	■■■■■
PGN-plus-P	100	-1-AS/1-IS (6 bar)	■■■■■
PGN-plus-P	100	-2 (6 bar)	■■■■■
PGN-plus-P	100	-2-AS/2-IS (6 bar)	■■■■■
Legend			
■■■■■	Can be combined without restrictions		
■■□□	Use with restrictions (see loading limits)		
□□□□	cannot be combined		

The load limits for describing the application limits can be found in the catalog chapter of the corresponding accessories.

Jaw quick-change system BSWS-M

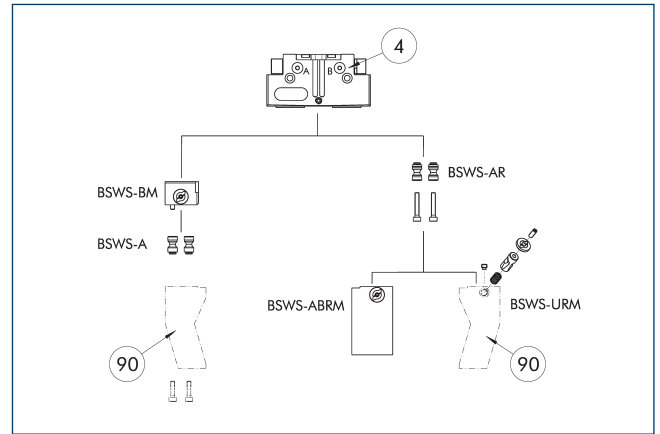

④ Grippers ⑨0 Customized gripper fingers

There are various jaw quick-change systems available for the gripper. For detailed information, please refer to the corresponding product.

Description	ID	Scope of delivery
Jaw quick-change system adapter pin		
BSWS-A 100	0303026	2
BSWS-AR 100	0300094	2
Quick-change jaw system base		
BSWS-BM 100	1313902	1
Jaw quick-change system finger blank		
BSWS-ABRM-PGZN-plus 100	1420853	1
Jaw quick-change system locking mechanism		
BSWS-URM 100	1398403	1

① If the operating pressure is higher than 6 bar, suitability for use beyond the application limits must be checked. Only systems that are listed in the table, can be used.

Fields of application

Series	Size	Variant	Suitability
PGN-plus-P	100	-1 (6 bar)	■■■■■
PGN-plus-P	100	-1-AS/1-IS (6 bar)	■■■■■
PGN-plus-P	100	-2 (6 bar)	■■■■■
PGN-plus-P	100	-2-AS/2-IS (6 bar)	■■■■■
Legend			
■■■■■	Can be combined without restrictions		
■■□□	Use with restrictions (see loading limits)		
□□□□	cannot be combined		

The load limits for describing the application limits can be found in the catalog chapter of the corresponding accessories.

ZBA-L-plus 100 intermediate jaws

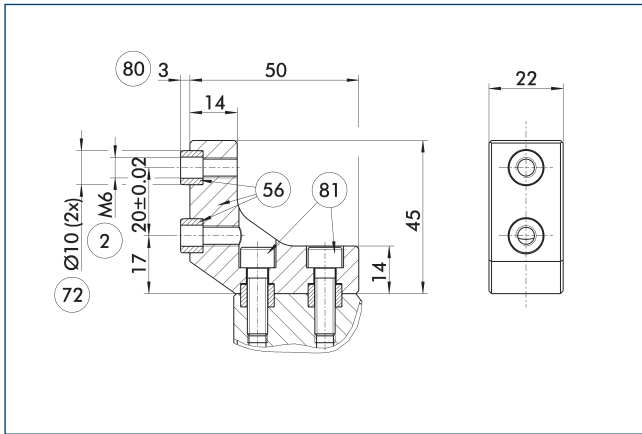

- ② Finger connection
- ⑤⑥ Included in the scope of delivery
- ⑦② Fit for centering sleeves
- ⑧① Depth of the centering sleeve hole in the counter part
- ⑧① Not included in the scope of delivery

The optional ZBA-L-plus intermediate jaws allow the screw connection diagram of the top jaws to be rotated by 90°. This makes it easier to design and produce top jaws (particularly for long versions) because no deep through-bores are required.

Description	ID	Material	Finger interface	Scope of delivery
Intermediate jaw				
ZBA-L-plus 100	0311742	Aluminum	PGN-plus 100	1

UZB 100 universal intermediate jaw

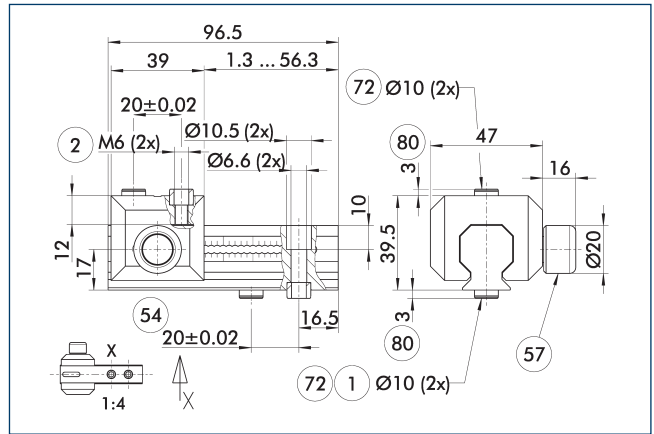

- ① Gripper connection
- ② Finger connection
- ⑤④ Optional right or left connection
- ⑤⑦ Locking
- ⑦② Fit for centering sleeves
- ⑧① Depth of the centering sleeve hole in the counter part

The drawing shows the UZB universal intermediate jaw. The fully removable UZB-S slide (can also be ordered separately) allows for a quick jaw change.

Description	ID	Grid dimension
Universal intermediate jaw		
UZB 100	0300044	2.5
Finger blank		
ABR-PGZN-plus 100	0300012	
SBR-PGZN-plus 100	0300022	
Slide for universal intermediate jaw		
UZB-S 100	5518272	2.5

ⓘ If the operating pressure is higher than 6 bar, suitability for use beyond the application limits must be checked.

Fields of application

Series	Size	Variant	Suitability
PGN-plus-P	100	-1 (6 bar)	■■■■
PGN-plus-P	100	-1-AS/1-IS (6 bar)	■■□□
PGN-plus-P	100	-2 (6 bar)	■■□□
PGN-plus-P	100	-2-AS/2-IS (6 bar)	□□□□
Legend			
■■■■	Can be combined without restrictions		
■■□□	Use with restrictions (see loading limits)		
□□□□	cannot be combined		

The load limits for describing the application limits can be found in the catalog chapter of the corresponding accessories.

PGN-plus-P 100

Universal gripper

Finger blanks ABR/SBR-PGZN-plus 100

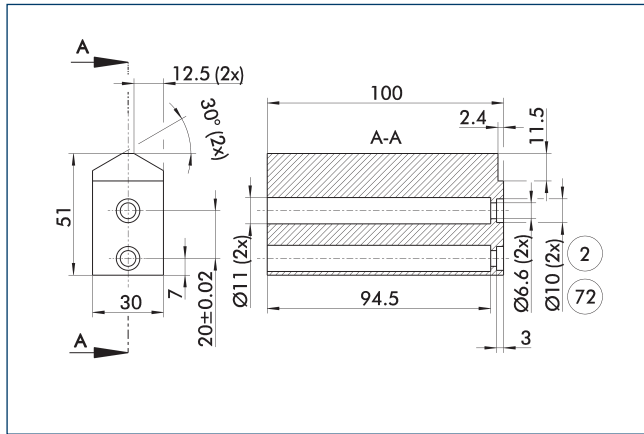

- 2 Finger connection
- 72 Fit for centering sleeves

The drawing shows the finger blank which can be reworked by the customer.

Description	ID	Material	Scope of delivery
Finger blank			
ABR-PGZN-plus 100	0300012	Aluminum (3.4365)	1
SBR-PGZN-plus 100	0300022	Steel (1.7131)	1

① In the PGL-plus-P gripper series, the use of finger blanks results in a limitation of the closing stroke. Please check this in detail in advance using the CAD data and adjust the reworking of the fingers accordingly.

Compensation unit AGE-F

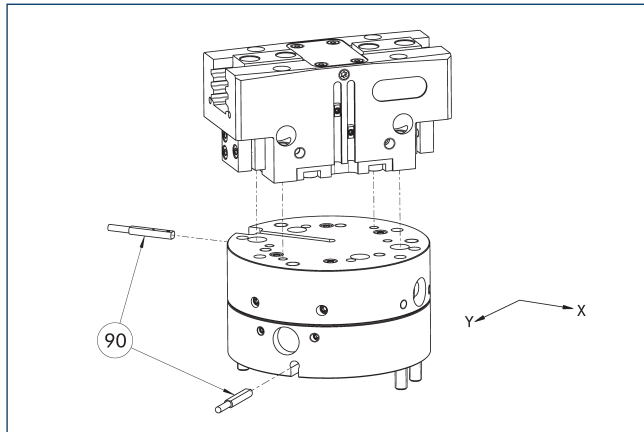

- 90 Monitoring

The unit has direct connection possibilities for different grippers of the PGN-plus, PGN-plus-P and PZN-plus series. For more detailed information, please refer to the main view.

Description	ID	Compensation XY	Reset force	Often combined
		[mm]	[N]	
Compensation unit				
AGE-F-XY-080-1	0324960	± 5	39	
AGE-F-XY-080-2	0324961	± 5	85	
AGE-F-XY-080-3	0324962	± 5	90	●

① Due to the interfering contour, monitoring of the gripper is not possible.

Tolerance compensation unit TCU

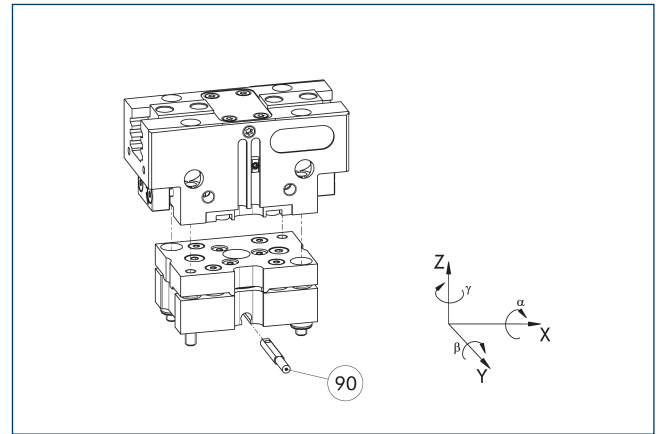

- 90 Monitoring of locking

Grippers can be directly mounted without an adapter plate. Tolerance compensation unit and gripper have an identical screw connection diagram. Therefore the tolerance compensation units can be assembled later. Please consider the additional assembly height of the tolerance compensation unit. For details please refer to our catalog robot accessories.

Description	ID	Locking	Deflection	Often combined
Compensation unit				
TCU-P-100-2-MV	0324808	yes	±1°/±1,5°/±1,2°	●
TCU-P-100-3-0V	0324811	no	±1°/±1,5°/±1,2°	

Adapter plate for PGN-plus 100

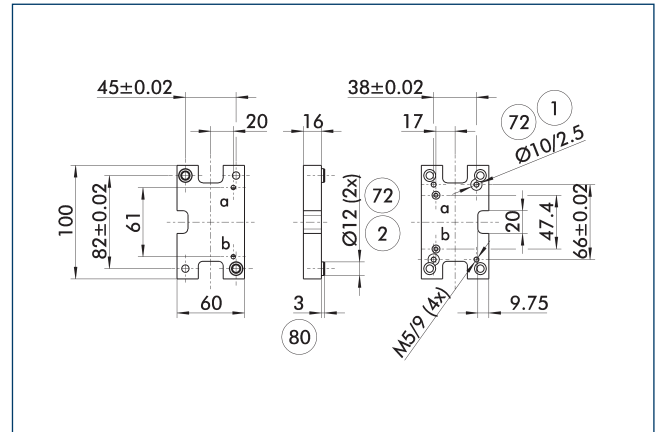

- 1 Robot-side connection
- 2 Tool-side connection
- 72 Fit for centering sleeves
- 80 Depth of the centering sleeve hole in the counter part

The adapter plate has integrated air feed-throughs in order to be able to use the hose-free direct connection of the appropriate gripper.

Description	ID
Tool side	
A-CWA-125-100-P	0305829

Compact change system for grippers

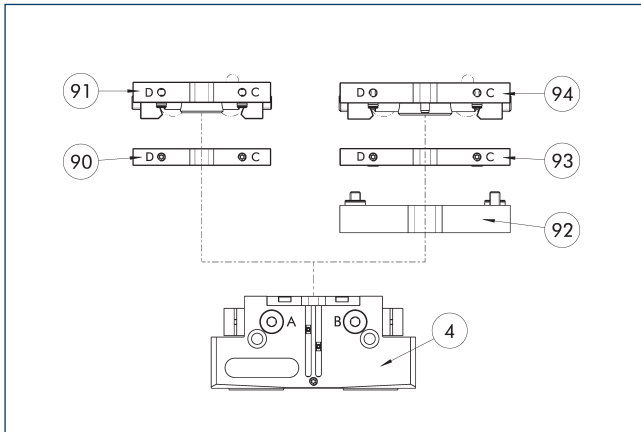

- ④ Grippers
- ⑨② A-CWA adapter plate
- ⑨① CWK compact change master
- ⑨④ CWK compact change master
- ⑨② Sensor distributor
- ⑨③ CWA compact change adapter
- ⑨① Micro valves
- ⑨③ Y distributor

Grippers can be directly mounted without an adapter plate. For details see our catalog Gripping or Robot Accessories.

Description	ID
Tool side	
A-CWA-125-100-P	0305829
CWA compact change adapter	
CWA-100-P	0305801
CWK compact change master	
CWK-100-P	0305800

Add-on valves for single grippers

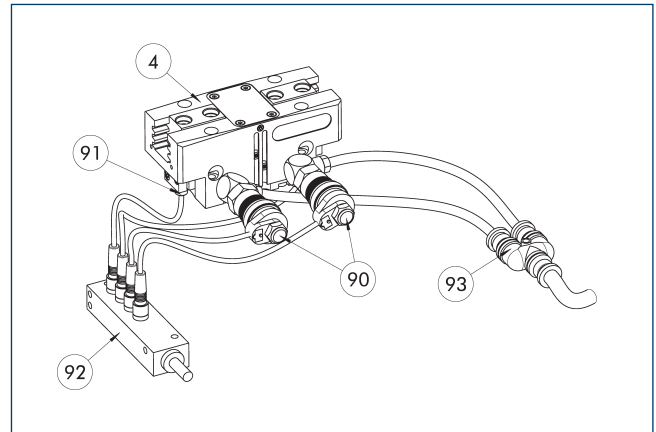

- ④ Grippers
- ⑨② Sensor distributor
- ⑨① Micro valves
- ⑨③ Y distributor
- ⑨① Sensor

The set of attachment valves reduces the compressed air consumption as there is no need to ventilate or bleed the supply lines. This can also reduce cycle time. The hose-free direct assembly of the micro valves reduces the hosing effort for the gripper. To further simplify electrical connection of the valves and sensors, their signals can be bundled via an optional distributor.

Description	ID	Often combined
Add-on valve set		
ABV-MV30-G1/8	0303328	
ABV-MV30-G1/8-V2-M8	0303396	
ABV-MV30-G1/8-V4-M8	0303366	●

- ① A set of add-on valves ABV is required per actuator. The ABV set contains two 3/2 micro valves, an Y-distributor for compressed air supply and optionally a sensor distributor with two or four inputs or outputs. Sensors for monitoring the gripper need to be ordered separately. Pneumatic hoses are not included in the scope of delivery.

PGN-plus-P 100

Universal gripper

Add-on valves for double grippers

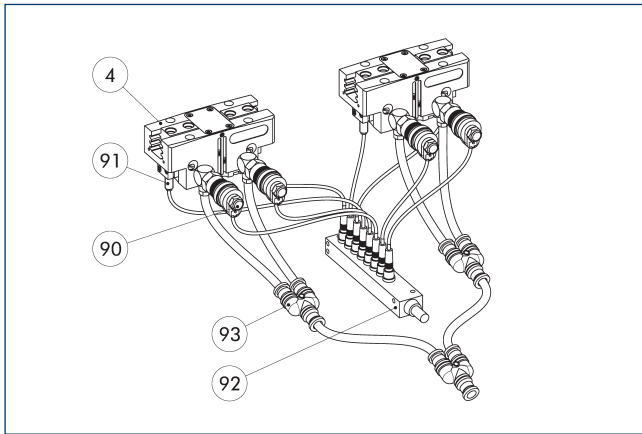

- ④ Grippers
- ⑨① Sensor
- ⑨② Sensor distributor
- ⑨③ Y distributor
- ⑨④ Micro valves

The add-on valve set reduces compressed air consumption as there is no need to ventilate or bleed the supply lines. This can also reduce cycle time. The hose-free direct assembly of the micro valves reduces the hosing effort for the gripper. To further simplify electrical connection of the valves and sensors, their signals can be bundled via a distributor.

Description	ID
Add-on valve set	
ABV-MV30-G1/8-V8-M8	0303367

ⓘ A set of add-on valves ABV is required per double gripping unit. The ABV set contains four 3/2 microvalves, three Y-distributors for compressed air supply and a sensor distributor with eight inputs or outputs. Sensors for monitoring the gripper need to be ordered separately. Pneumatic hoses are not included in the scope of delivery.

Modular Assembly Automation

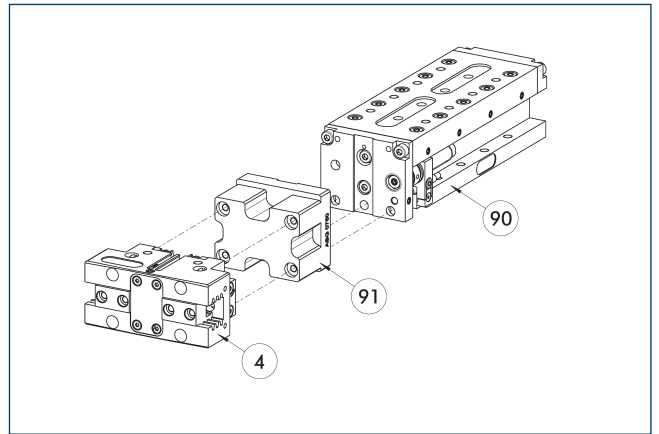

- ④ Grippers
- ⑨① ASG adapter plate
- ⑨④ Linear module CLM/KLM/LM/ELP/ELM/ELS/HLM

Grippers and linear modules can be combined with standard adapter plates from the modular assembly system. For more information see our main catalog "Modular Assembly Automation".

Inductive proximity switches

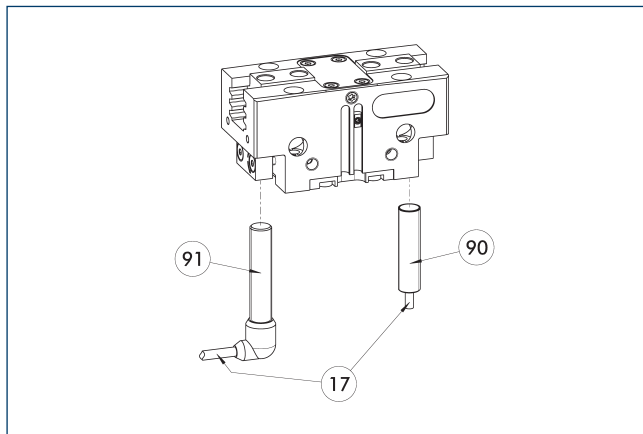

- ①⑦ Cable outlet
- ①⑨ Sensor IN...-SA
- ①⑩ Sensor IN ...

Directly mounted end position monitoring.

Description	ID	Often combined
Inductive proximity switches		
IN 80-S-M12	0301578	
IN 80-S-M8	0301478	●
INK 80-S	0301550	
Inductive proximity switch with lateral cable outlet		
IN 80-S-M12-SA	0301587	
IN 80-S-M8-SA	0301483	●
INK 80-S-SA	0301566	
Connection cables		
KA BG08-L 3P-0300-PNP	0301622	●
KA BG08-L 3P-0500-PNP	0301623	
KA BG12-L 3P-0500-PNP	30016369	
KA BW08-L 3P-0300-PNP	0301594	
KA BW08-L 3P-0500-PNP	0301502	
KA BW12-L 3P-0300-PNP	0301503	
KA BW12-L 3P-0500-PNP	0301507	
Clip for connector/socket		
CLI-M12	0301464	
CLI-M8	0301463	
Cable extension		
KV BG12-SG12 3P-0030-PNP	0301999	
KV BG12-SG12 3P-0060-PNP	0301998	
KV BW08-SG08 3P-0030-PNP	0301495	
KV BW08-SG08 3P-0100-PNP	0301496	
KV BW08-SG08 3P-0200-PNP	0301497	●
KV BW12-SG12 3P-0030-PNP	0301595	
KV BW12-SG12 3P-0100-PNP	0301596	
KV BW12-SG12 3P-0200-PNP	0301597	
Sensor distributor		
V2-M12	0301776	●
V2-M8	0301775	●
V4-M8	0301746	
V8-M8	0301751	

- ① Two sensors are required per unit for monitoring two positions. On option, extension cables and sensor distributors are available. Additional product variants of the sensor, and further information and technical data can be found in the catalog chapter sensor system.

Flexible position sensor

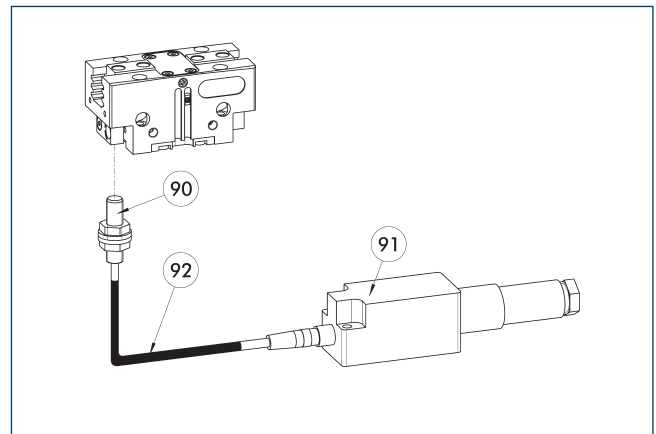

- ①⑩ FPS-S sensor
- ①⑩ FPS-F5 evaluation electronic
- ①② Cable extension

Flexible position monitoring of up to five positions.

Description	ID	
Attachment kit for FPS		
AS-FPS-PGN-plus-P 100	1363897	
Sensor		
FPS-S M8	0301704	
Evaluation electronics		
FPS-F5	0301805	
Cable extension		
KV BG08-SG08 3P-0050	0301598	
KV BG08-SG08 3P-0100	0301599	

- ① When using an FPS system, an FPS sensor (FPS-S) as well as an electronic processor (FPS-F5 / F5 T) are required for each gripper as well as a mounting kit (AS), if listed. Cable extensions (KV) are optionally available – see catalog chapter “Accessories.”

PGN-plus-P 100

Universal gripper

Electronic magnetic switch MMS

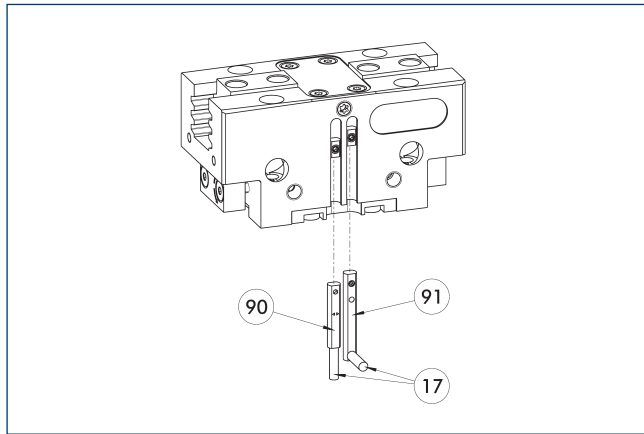

- ①⑦ Cable outlet
- ①⑨ Sensor MMS 22...
- ①⑩ Sensor MMS 22..

End position monitoring for mounting in the C-slot.

Description	ID	Often combined
Electronic magnetic switch		
MMS 22-S-M8-PNP	0301032	●
MMSK 22-S-PNP	0301034	
Electronic magnetic switches with lateral cable outlet		
MMS 22-S-M8-PNP-SA	0301042	●
MMSK 22-S-PNP-SA	0301044	
Connection cables		
KA BG08-L 3P-0300-PNP	0301622	●
KA BG08-L 3P-0500-PNP	0301623	
KA BW08-L 3P-0300-PNP	0301594	
KA BW08-L 3P-0500-PNP	0301502	
Clip for connector/socket		
CLI-M8	0301463	
Cable extension		
KV BW08-SG08 3P-0030-PNP	0301495	
KV BW08-SG08 3P-0100-PNP	0301496	
KV BW08-SG08 3P-0200-PNP	0301497	●
Sensor distributor		
V2-M8	0301775	●
V4-M8	0301746	
V8-M8	0301751	

- ① Two sensors are required per unit for monitoring two positions. On option, extension cables and sensor distributors are available. Additional product variants of the sensor, and further information and technical data can be found in the catalog chapter sensor system.

Programmable magnetic switch MMS 22-PI1

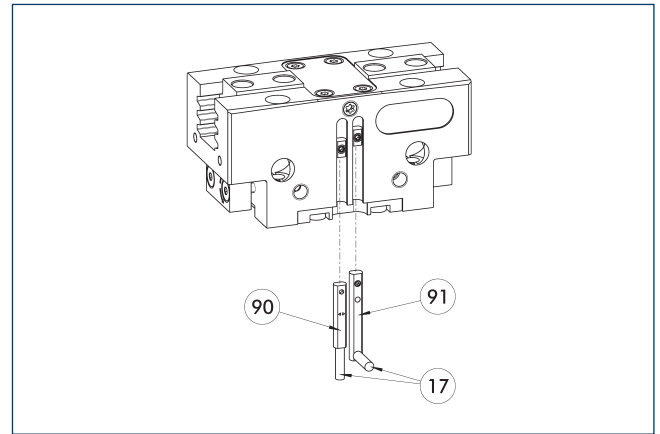

- ①⑦ Cable outlet
- ①⑨ Sensor MMS 22 ..-PI1-...-SA
- ①⑩ Sensor MMS 22 PI1-...

Position monitoring with one programmable position per sensor and integrated electronic system in the sensor. Can be programmed using MT magnetic teaching tool (included in the scope of delivery, ID 0301030) or ST plug teaching tool (optional). End position monitoring for mounting in the C-slot. If the ST plug teaching tools are listed in the table provided, teaching is only possible with the ST teaching tools.

Description	ID	Often combined
Programmable magnetic switch		
MMS 22-PI1-S-M8-PNP	0301160	●
MMSK 22-PI1-S-PNP	0301162	
Programmable magnetic switch with lateral cable outlet		
MMS 22-PI1-S-M8-PNP-SA	0301166	●
MMSK 22-PI1-S-PNP-SA	0301168	
Programmable magnetic switch with stainless steel housing		
MMS 22-PI1-S-M8-PNP-HD	0301110	●
MMSK 22-PI1-S-PNP-HD	0301112	

- ① Two sensors are required per unit for monitoring two positions. On option, extension cables and sensor distributors are available. Additional product variants of the sensor, and further information and technical data can be found in the catalog chapter sensor system.

Programmable magnetic switch MMS 22-PI2

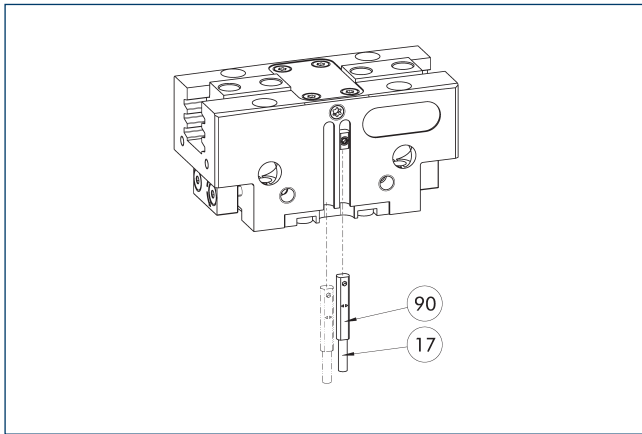

17 Cable outlet

90 MMS 22...-PI2-... sensor

Position monitoring with two programmable positions per sensor and electronics integrated in the sensor. Can be programmed using MT magnetic teaching tool (included in the scope of delivery, ID 0301030) or ST plug teaching tool (optional). End position monitoring for mounting in the C-slot. If the ST plug teaching tools are listed in the table provided, teaching is only possible with the ST teaching tools.

Description	ID	Often combined
Programmable magnetic switch		
MMS 22-PI2-S-M8-PNP	0301180	●
MMSK 22-PI2-S-PNP	0301182	
Programmable magnetic switch with lateral cable outlet		
MMS 22-PI2-S-M8-PNP-SA	0301186	●
MMSK 22-PI2-S-PNP-SA	0301188	
Programmable magnetic switch with stainless steel housing		
MMS 22-PI2-S-M8-PNP-HD	0301130	●
MMSK 22-PI2-S-PNP-HD	0301132	

- ① One sensor is required per unit for monitoring two positions. Extension cables and sensor distributors are optionally available. Additional product variants of the sensor, and further information and technical data can be found in the catalog chapter sensor systems.

MMS-P programmable magnetic switch

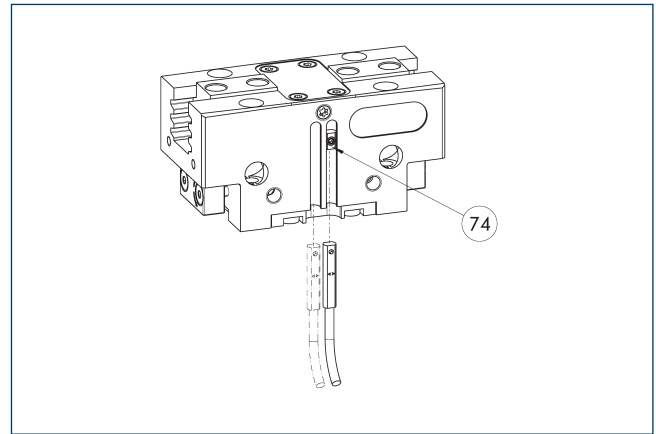

74 Limit stop for sensor

Position monitoring with two programmable positions per sensor. End position monitoring for mounting in the C-slot.

Description	ID	Often combined
Programmable magnetic switch		
MMSK-P 22-S-PNP	0301371	
MMS-P 22-S-M8-PNP	0301370	●
Connection cables		
KA GLN0804-LK-00500-A	0307767	●
KA GLN0804-LK-01000-A	0307768	
KA WLN0804-LK-00500-A	0307765	
KA WLN0804-LK-01000-A	0307766	
Clip for connector/socket		
CLI-M8	0301463	
Sensor distributor		
V2-M8-4P-2XM8-3P	0301380	

- ① One sensor is required per unit for monitoring two positions. Extension cables and sensor distributors are optionally available. Additional product variants of the sensor, and further information and technical data can be found in the catalog chapter sensor systems.

PGN-plus-P 100

Universal gripper

Analog position sensor MMS-A

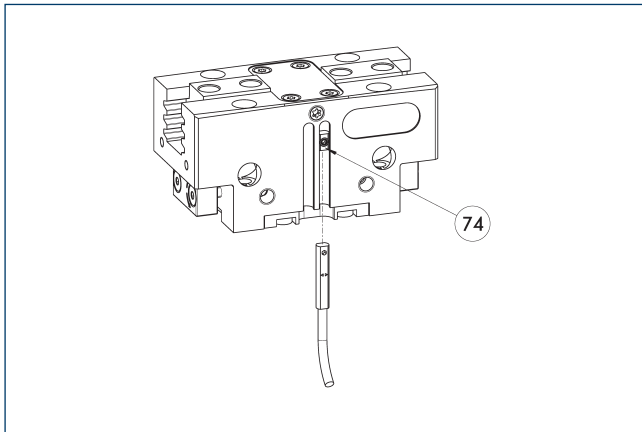

74 Limit stop for sensor

Non-contact measuring, analog multi-position monitoring for any number of positions, easy to assemble in the C-slot. Can be programmed using MT magnetic teaching tool (included in the scope of delivery, ID 0301030) or ST plug teaching tool (optional). End position monitoring for mounting in the C-slot. If the ST plug teaching tools are listed in the chart provided, teaching is only possible with the ST teaching tools.

Description	ID	
Analog position sensor		
MMS 22-A-10V-M08	0315825	
MMS 22-A-10V-M12	0315828	

① One sensor is required for each gripper. No additional mounting kit is required – the gripper is equipped for use of the sensor by default. Further information and technical data can be found in the catalog chapter sensor systems.

Flexible position sensor with MMS-A

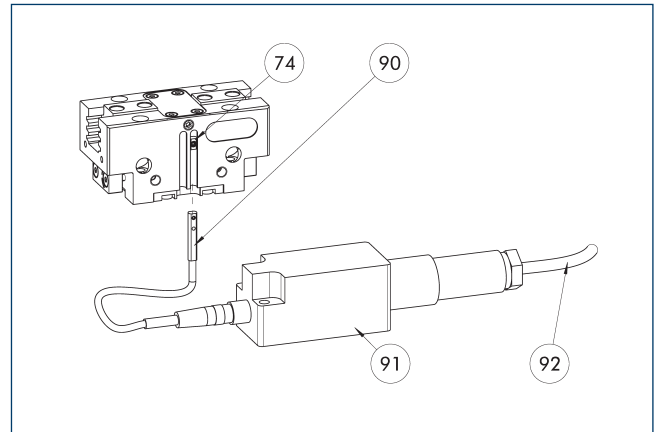

74 Limit stop for sensor

90 MMS 22-A-... sensor

91 FPS-F5 evaluation electronic

92 Connection cables

Flexible position monitoring of up to five positions. Sensor can be taught using MT magnetic teaching tool (included in the scope of delivery, ID 0301030) or ST plug teaching tool (optional). If the ST plug teaching tools are listed in the table provided, teaching is only possible with the ST teaching tools.

Description	ID	
Analog position sensor		
MMS 22-A-05V-M08	0315805	
Evaluation electronics		
FPS-F5	0301805	
Sensor Teaching Tool		
MT-MMS 22-PI	0301030	
Connection cables		
KA BG16-L 12P-1000	0301801	

① When using an FPS system, one MMS 22-A-05V and one evaluation electronics (FPS-F5) are required per each gripper, as well as an attachment kit (AS), if listed. On option, cable extensions (KV) are available – see catalog chapter "Accessories."

Programmable magnetic switch MMS-IO-Link

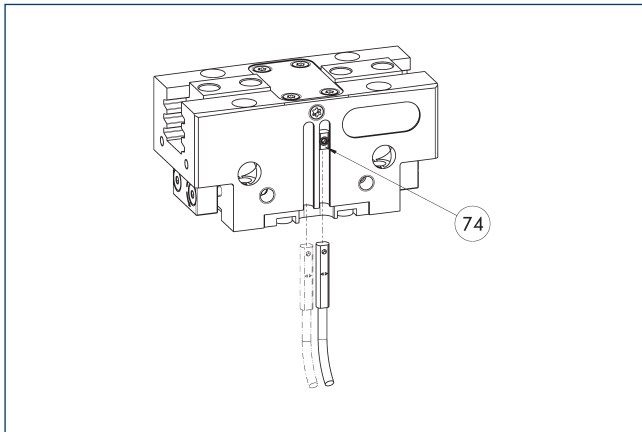

74 Limit stop for sensor

Sensor for multi-position monitoring through detection of the complete gripper stroke. The sensor is mounted directly in the C-slot of the gripper. The sensor is programmed for the gripper via the IO-Link interface, Magnet teaching tool MT (included in scope of delivery; ID 0301030) or the ST plug teaching tool (not included in scope of delivery; ID 0301026). An IO-Link master is required for operation.

Description	ID	
Programmable magnetic switch		
MMS 22-IOL-M08	0315830	
MMS 22-IOL-M12	0315835	

- ① One sensor is required for each gripper. No additional mounting kit is required – the gripper is equipped for use of the sensor by default. Further information and technical data can be found in the catalog chapter sensor systems.

APS-Z80 analog position sensor

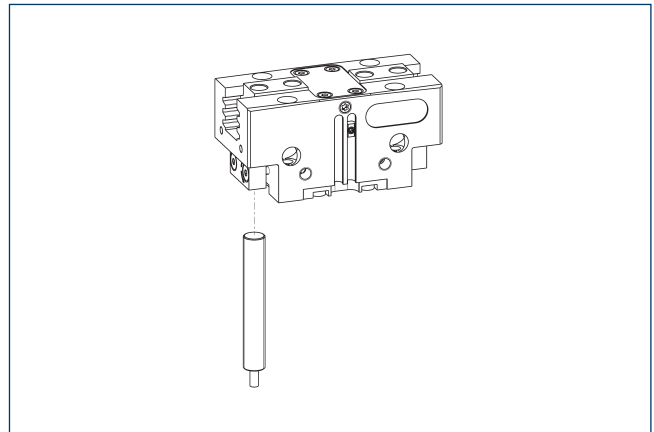

Non-contact measuring, analog multi-position monitoring for any number of positions.

Description	ID	Often combined
Mounting kit for APS-Z80		
AS-APS-Z80-PGN-plus-P 100-1	1366219	
AS-APS-Z80-PGN-plus-P 100-2	1366224	
Analog position sensor		
APS-Z80-K	0302072	
APS-Z80-M8	0302070	●

- ① When using an APS system, one mounting kit (AS-APS-Z80) and one APS-Z80 sensor is required per gripper. The resolution of the sensor can be lower in the peripheral areas of the gripper. You can find further information on the product in the operating manual.

PGN-plus-P 100

Universal gripper

APS-M1 analog position sensor

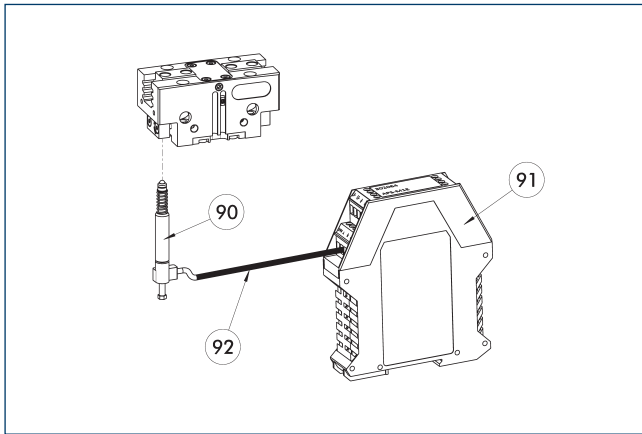

- ⑨⑩ APS-M1S sensor
- ⑨① APS-M1E electronic processor
- ⑨② APS-K extension cable

Analog multi position monitoring for any desired positions

Description	ID	
Mounting kit for APS-M1		
AS-APS-M1-PGN-plus-P 100-1	1363733	
AS-APS-M1-PGN-plus-P 100-2	1363737	
Analog position sensor		
APS-M1S	0302062	
Connection cables		
APS-K0200	0302066	
APS-K0700	0302068	
Evaluation electronics		
APS-M1E	0302064	

- ① When using an APS system, for each gripper an attachment kit (AS-APS-M1), an APS-M1S sensor (incl. 3 m cable) as well as an electronics (APS-M1e) are required. An extension cable (APS-K) can be connected between the sensor and the electronics as an option. The max. cable length between the sensor and the electronics is 10 m, between the electronics and their control unit (PLC) it is max. 1 m.

PGN-plus-P 125

Universal gripper



Gripping force O.D. gripping

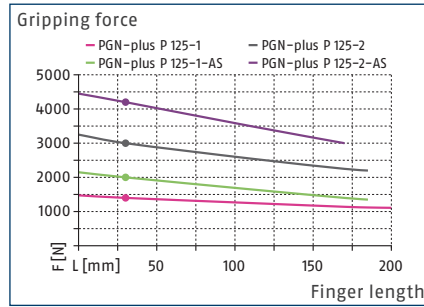

Gripping force I.D. gripping

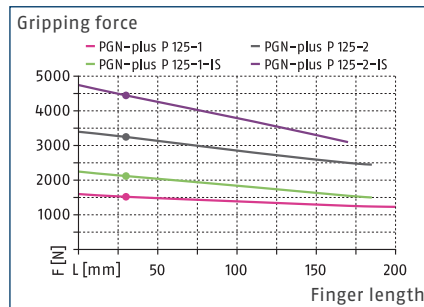

Dimensions and maximum loads

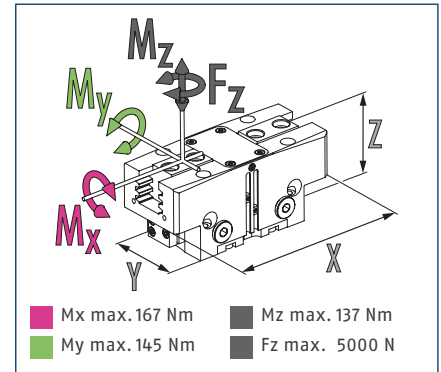

① The indicated moments and forces are static values, apply for each base jaw and may appear simultaneously. Loads may additionally occur to the moment produced by the gripping force itself.

Technical data

Description		PGN-plus-P 125-1	PGN-plus-P 125-2	PGN-plus-P 125-1-AS	PGN-plus-P 125-2-AS	PGN-plus-P 125-1-IS	PGN-plus-P 125-2-IS
ID		0318568	0318569	0318570	0318571	0318572	0318573
Stroke per jaw	[mm]	13	6	13	6	13	6
Closing/opening force	[N]	1400/1520	3000/3250	2000/-	4200/-	-/2120	-/4450
Min. spring force	[N]			600	1200	600	1200
Weight	[kg]	1.4	1.4	1.9	1.9	1.9	1.9
Recommended workpiece weight	[kg]	7	15	7	15	7	15
Fluid consumption double stroke	[cm³]	110	110	160	160	185	185
Min./nom./max. operating pressure	[bar]	2.5/6/8	2.5/6/8	4/6/6.5	4/6/6.5	4/6/6.5	4/6/6.5
Min./max. air purge pressure	[bar]	0.5/1	0.5/1	0.5/1	0.5/1	0.5/1	0.5/1
Closing/opening time	[s]	0.09/0.09	0.09/0.09	0.08/0.12	0.08/0.12	0.12/0.08	0.12/0.08
Closing/opening time with spring	[s]			0.15	0.15	0.15	0.15
Max. permissible finger length	[mm]	200	185	185	170	185	170
Max. permissible weight per finger	[kg]	2.4	2.4	2.4	2.4	2.4	2.4
IP protection class		40	40	40	40	40	40
Min./max. ambient temperature	[°C]	5/90	5/90	5/90	5/90	5/90	5/90
Repeat accuracy	[mm]	0.01	0.01	0.01	0.01	0.01	0.01
Dimensions X x Y x Z	[mm]	151 x 60 x 63	151 x 60 x 63	151 x 60 x 93	151 x 60 x 93	151 x 60 x 93	151 x 60 x 93
Options and their characteristics							
Dustproof version		1317584	1317585	1317590	1317591	1317592	1317593
IP protection class		64	64	64	64	64	64
Weight	[kg]	1.6	1.6	2.1	2.1	2.1	2.1
Corrosion-protected version		38318568	38318569	38318570	38318571	38318572	38318573
High-temperature version		39318568	39318569	39318570	39318571	39318572	39318573
Min./max. ambient temperature	[°C]	5/130	5/130	5/130	5/130	5/130	5/130
Precision version		0318574	0318575	0318576	0318577		

① It may take a few 100 gripping cycles until the full gripping force (as indicated in the data table) will be available.

PGN-plus-P 125

Universal gripper

Maximum permitted finger projection

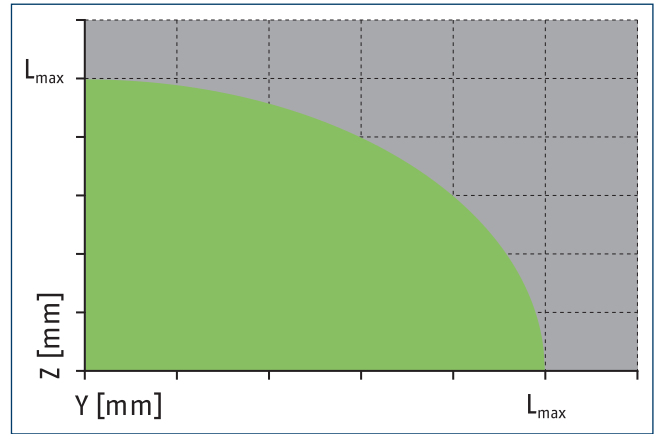
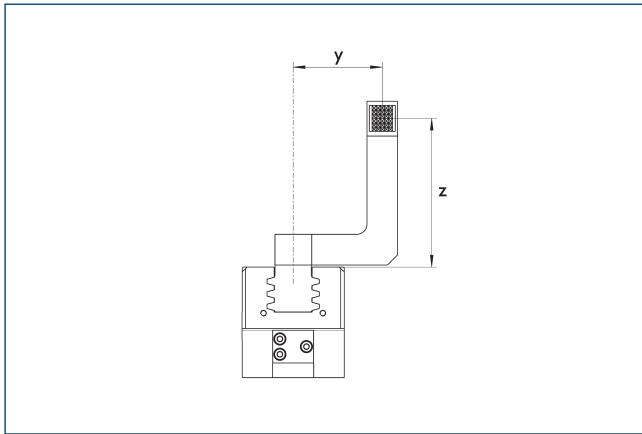

■ Permitted range ■ Inadmissible range

L_{max} is equivalent to the maximum permitted finger length, see the technical data table.

Hose-free direct connection M5

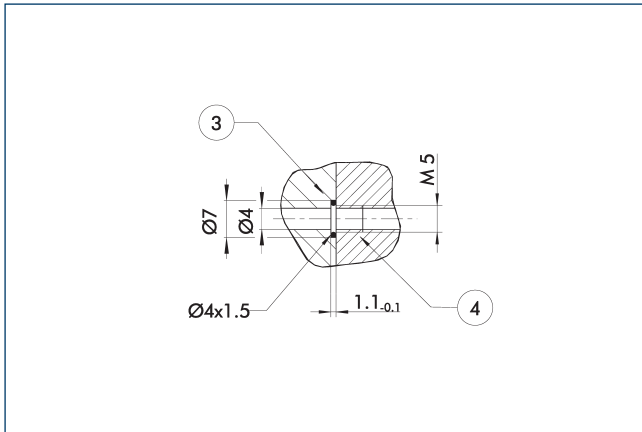

③ Adapter

④ Grippers

The direct connection is used for supplying compressed air without hoses. Instead, the pressure medium is fed through bore-holes in the mounting plate.

Gripping force maintenance version AS/IS

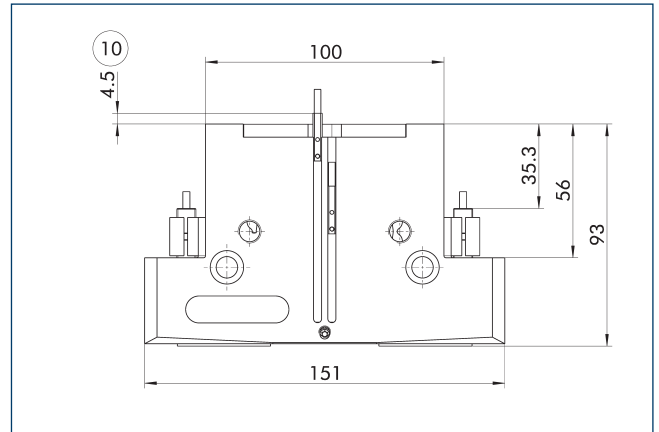

⑩ Projection applies only for AS version

The mechanical gripping force maintenance device ensures that a minimum clamping force will be applied even if there is a drop in pressure. In the AS/S variant this acts as a closing force, in the IS variant as an opening force. Besides this, gripping force maintenance can be used to increase gripping force or for single actuated gripping.

Dustproof version

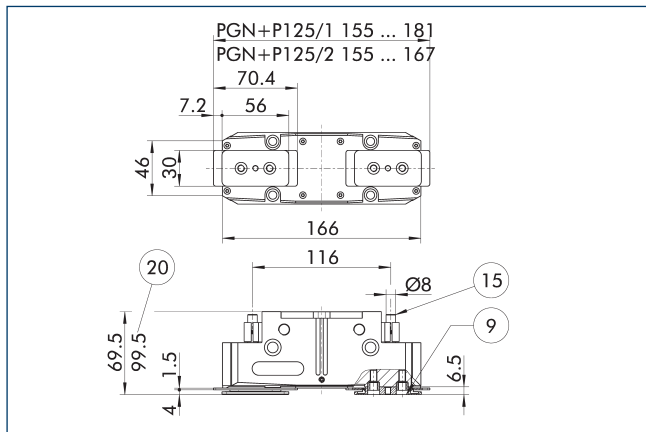

- ⑨ For mounting screw connection diagram, see basic version
- ⑮ Sealing bolt
- ⑳ For version AS/IS

The "dustproof" option increases the degree of protection against penetrating substances. The assembly diagram shifts by the height of the intermediate jaw. The finger length is still measured from the upper edge of the gripper housing.

Description	ID
Dust cover	
SAD PGN-plus-P 125	1347572

- ① The "dustproof" option can either be ordered as a pre-mounted gripper version or can be retrofitted to the gripper using the "SAD PGN-plus-P" retrofit kit.

Precision version

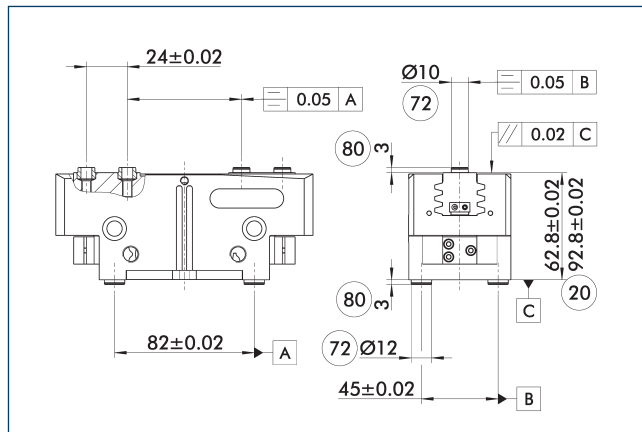

- ⑳ For version AS/IS
- ㉓ Fit for centering sleeves
- ㉔ Depth of the centering sleeve hole in the counter part

The indicated tolerances just refer to the variants of precision versions shown in the chart of technical specifications. All other variants of precision versions are available on request.

PGN-plus-P 125

Universal gripper

SDV-P pressure maintenance valve

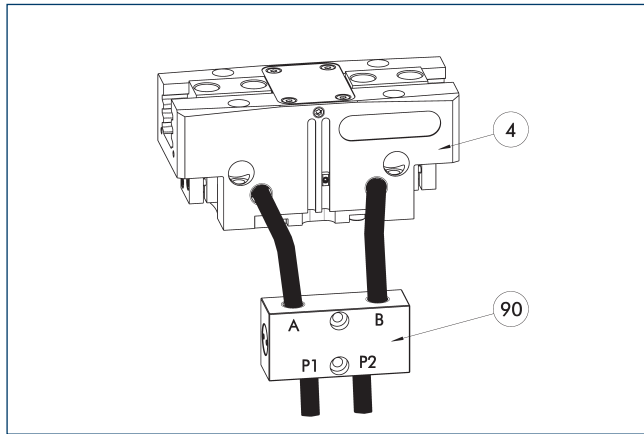

- ④ Grippers
- ⑨⑩ SDV-P pressure maintenance valve

The SDV-P pressure maintenance valve ensures in emergency STOP situations that the pressure in the piston chamber of pneumatic gripper, swivel, linear, and quick-change modules is temporarily maintained.

Description	ID	Recommended hose diameter [mm]
Pressure maintenance valve		
SDV-P 04	0403130	6
SDV-P 07	0403131	8
Pressure maintenance valve with air bleed screw		
SDV-P 04-E	0300120	6
SDV-P 07-E	0300121	8

① In order to achieve the specified closing and opening time for each gripper variant, the recommended hose diameter must be used. The direct allocation of the respective variant of the gripper for the respective SDV-P can be found at schunk.com.

SDV-P E-P pressure maintenance valve

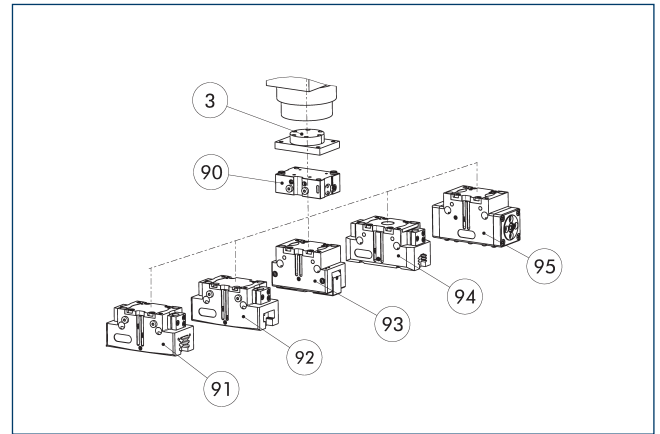

- ③ Adapter
- ⑨⑩ SDV-P E-P pressure maintenance valve
- ⑨① 2-finger parallel gripper
- ⑨② 2-finger parallel gripper JGP-P
- ⑨③ 2-finger angular gripper PWG-plus
- ⑨④ 2-finger parallel gripper PGB PGN-plus/PGN-plus-P
- ⑨⑤ Sealed DPG-plus gripper

The SDV-P E-P pressure maintenance valves ensure that the pressure in the piston chamber is maintained temporarily during an emergency stop. SDV-P E-P can be directly connected to the listed grippers without the need for additional pneumatic hoses.

Description	ID	
Pressure maintenance valve		
SDV-P 125-E-P	0300127	

Pneumatic positioning device PPD

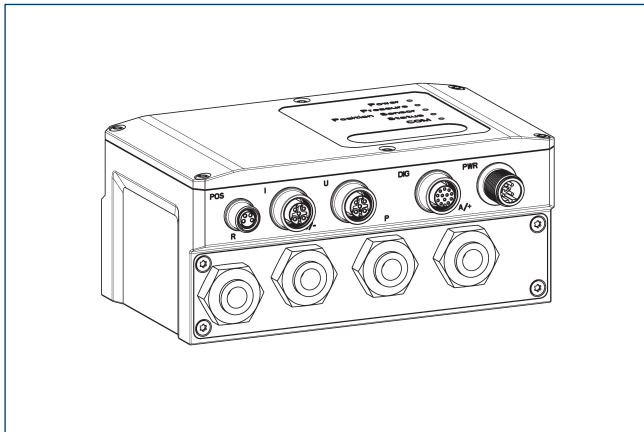

The PPD allows flexibility in all applications with pneumatic grippers through free positioning, gripping force and speed adjustment.

Description	ID	
Pneumatic positioning device		
PPD 20-IOL	1540700	
Adapter		
A GGN0804-1204-A	1540691	
IO-Link connection cable		
KA GGN1205-1212-IOL-00100-A	1540697	
Voltage supply connection cable - cable track compatible		
KA GLN12B05-LK-01000-A	1540660	
Cable extension		
KV GGN0804-I0-00150-A	1540662	
KV GGN0804-I0-00300-A	1540663	
Assembly set		
Assembly set PPD	1540705	

① In addition to the PPD, a position sensor (SCHUNK IO-Link sensor or analog sensor (4...20 mA)) is required.

Protective cover HUE PGN-plus 125

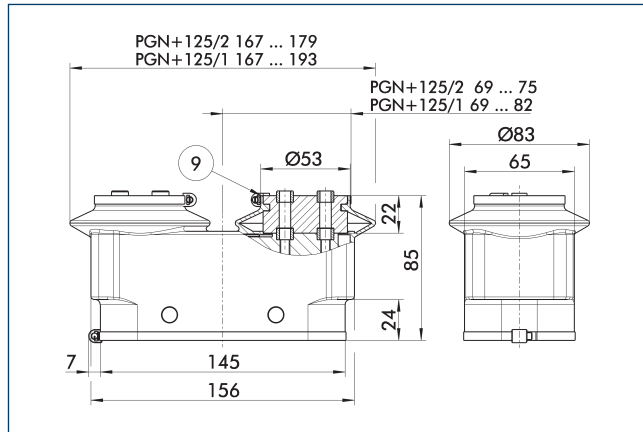

⑨ For mounting screw connection diagram, see basic version

The HUE protective cover fully protects the gripper against external influences. The cover is suitable for applications of up to IP65 if an additional sealing of the cover bottom is provided. For detailed information, please see the HUE series. The connection diagram shifts by the height of the intermediate jaw.

Description	ID	IP protection class
Protection cover		
HUE PGN-plus 125	0371483	65

① The HUE protective cover is not suitable for use on grippers with gripping force maintenance. An inductive monitoring of the gripper in connection with the HUE protective cover is not possible. SCHUNK recommends the use of magnetic sensors that are approved for the respective gripper variant.

PGN-plus-P 125

Universal gripper

BSWS jaw quick-change jaw systems

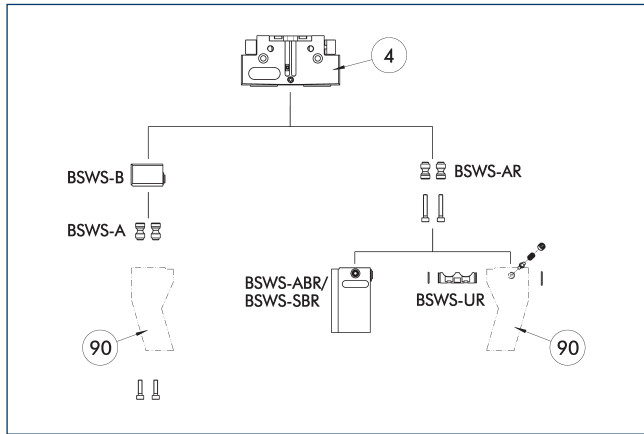

④ Grippers ⑨⑩ Customized gripper fingers

There are various jaw quick-change systems available for the gripper. For detailed information, please refer to the corresponding product.

Description	ID	Scope of delivery
Jaw quick-change system adapter pin		
BSWS-A 125	0303028	2
BSWS-AR 125	0300095	2
Quick-change jaw system base		
BSWS-B 125	0303029	1
Jaw quick-change system finger blank		
BSWS-ABR-PGZN-plus 125	0300075	1
BSWS-SBR-PGZN-plus 125	0300085	1
Jaw quick-change system locking mechanism		
BSWS-UR 125	0302994	1

① If the operating pressure is higher than 6 bar, suitability for use beyond the application limits must be checked. Only systems that are listed in the table, can be used. This accessory product can be used in combination with the gripper PGN-plus-P 125 only with stroke variant -1.

Fields of application

Series	Size	Variant	Suitability
PGN-plus-P	125	-1 (6 bar)	■■■■■
PGN-plus-P	125	-1-AS/1-IS (6 bar)	■■■■■
PGN-plus-P	125	-2 (6 bar)	■■■□□
PGN-plus-P	125	-2-AS/2-IS (6 bar)	■■■□□
Legend			
■■■■■	Can be combined without restrictions		
■■■□□	Use with restrictions (see loading limits)		
□□□□	cannot be combined		

The load limits for describing the application limits can be found in the catalog chapter of the corresponding accessories.

Jaw quick-change system BSWS-M

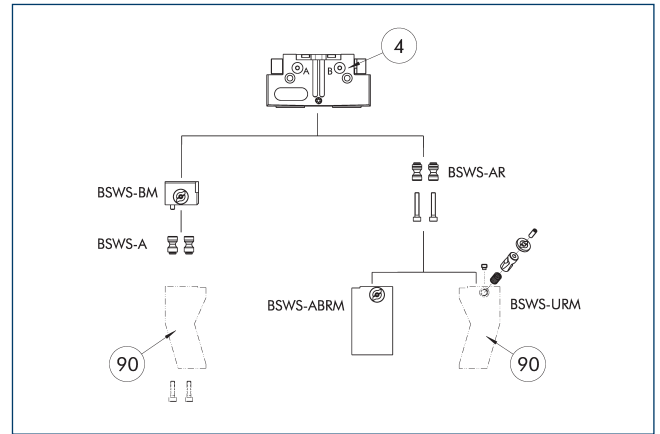

④ Grippers ⑨⑩ Customized gripper fingers

There are various jaw quick-change systems available for the gripper. For detailed information, please refer to the corresponding product.

Description	ID	Scope of delivery
Jaw quick-change system adapter pin		
BSWS-A 125	0303028	2
BSWS-AR 125	0300095	2
Quick-change jaw system base		
BSWS-BM 125	1302006	1
Jaw quick-change system finger blank		
BSWS-ABRM-PGZN-plus 125	1420854	1
Jaw quick-change system locking mechanism		
BSWS-URM 125	1398404	1

① If the operating pressure is higher than 6 bar, suitability for use beyond the application limits must be checked. Only systems that are listed in the table, can be used.

Fields of application

Series	Size	Variant	Suitability
PGN-plus-P	125	-1 (6 bar)	■■■■■
PGN-plus-P	125	-1-AS/1-IS (6 bar)	■■■■■
PGN-plus-P	125	-2 (6 bar)	■■■□□
PGN-plus-P	125	-2-AS/2-IS (6 bar)	■■■□□
Legend			
■■■■■	Can be combined without restrictions		
■■■□□	Use with restrictions (see loading limits)		
□□□□	cannot be combined		

The load limits for describing the application limits can be found in the catalog chapter of the corresponding accessories.

ZBA-L-plus 125 intermediate jaws

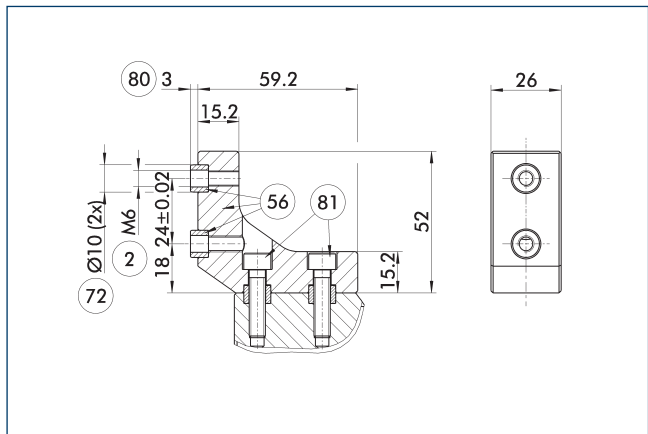

- ② Finger connection
- ⑤⑥ Included in the scope of delivery
- ⑦② Fit for centering sleeves
- ⑧① Depth of the centering sleeve hole in the counter part
- ⑧① Not included in the scope of delivery

The optional ZBA-L-plus intermediate jaws allow the screw connection diagram of the top jaws to be rotated by 90°. This makes it easier to design and produce top jaws (particularly for long versions) because no deep through-bores are required.

Description	ID	Material	Finger interface	Scope of delivery
Intermediate jaw				
ZBA-L-plus 125	0311752	Aluminum	PGN-plus 125	1

UZB 125 universal intermediate jaw

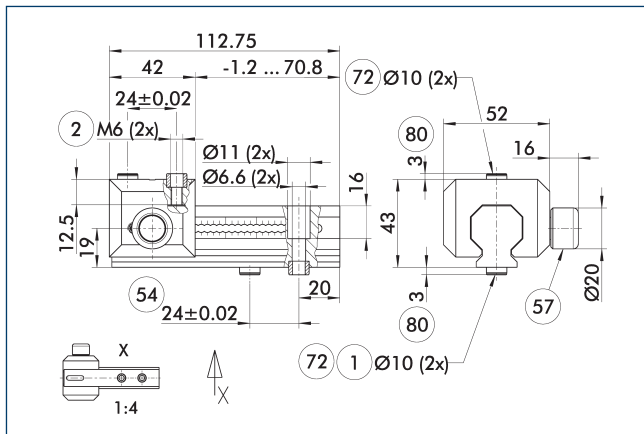

- ① Gripper connection
- ② Finger connection
- ⑤④ Optional right or left connection
- ⑤⑦ Locking
- ⑦② Fit for centering sleeves
- ⑧① Depth of the centering sleeve hole in the counter part

The drawing shows the UZB universal intermediate jaw. The fully removable UZB-S slide (can also be ordered separately) allows for a quick jaw change.

Description	ID	Grid dimension
		[mm]
Universal intermediate jaw		
UZB 125	0300045	3
Finger blank		
ABR-PGZN-plus 125	0300013	
SBR-PGZN-plus 125	0300023	
Slide for universal intermediate jaw		
UZB-S 125	5518273	3

ⓘ If the operating pressure is higher than 6 bar, suitability for use beyond the application limits must be checked.

Fields of application

Series	Size	Variant	Suitability
PGN-plus-P	125	-1 (6 bar)	■■■■
PGN-plus-P	125	-1-AS/1-IS (6 bar)	■■□□
PGN-plus-P	125	-2 (6 bar)	■■□□
PGN-plus-P	125	-2-AS/2-IS (6 bar)	□□□□

Legend	
■■■■	Can be combined without restrictions
■■□□	Use with restrictions (see loading limits)
□□□□	cannot be combined

The load limits for describing the application limits can be found in the catalog chapter of the corresponding accessories.

PGN-plus-P 125

Universal gripper

Finger blanks ABR/SBR-PGZN-plus 125

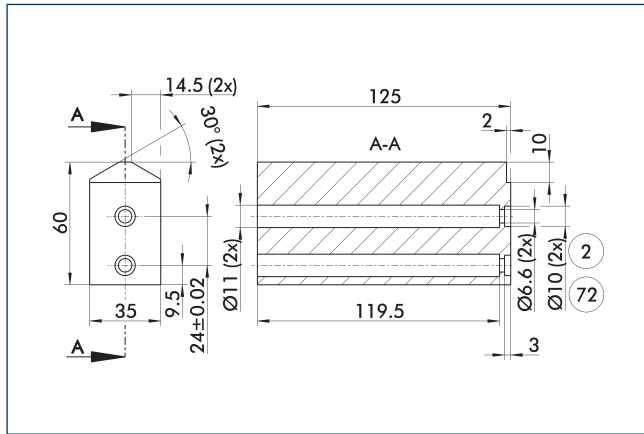

- ② Finger connection
- ⑦② Fit for centering sleeves

The drawing shows the finger blank which can be reworked by the customer.

Description	ID	Material	Scope of delivery
Finger blank			
ABR-PGZN-plus 125	0300013	Aluminum (3.4365)	1
SBR-PGZN-plus 125	0300023	Steel (1.7131)	1

① In the PGL-plus-P gripper series, the use of finger blanks results in a limitation of the closing stroke. Please check this in detail in advance using the CAD data and adjust the reworking of the fingers accordingly.

Compensation unit AGE-F

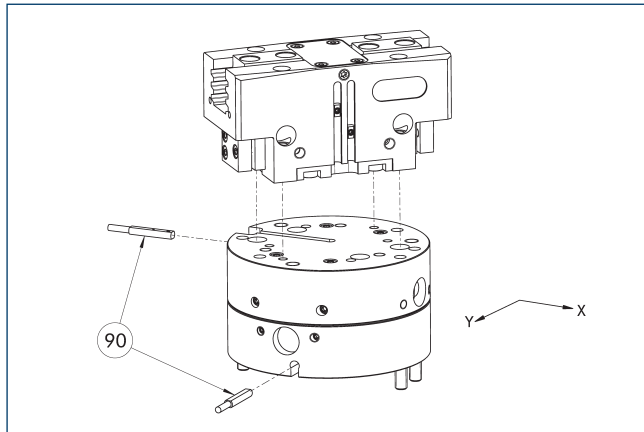

- ⑨⑩ Monitoring

The unit has direct connection possibilities for different grippers of the PGN-plus, PGN-plus-P and PZN-plus series. For more detailed information, please refer to the main view.

Description	ID	Compensation XY	Reset force	Often combined
		[mm]	[N]	
Compensation unit				
AGE-F-XY-080-1	0324960	± 5	39	
AGE-F-XY-080-2	0324961	± 5	85	
AGE-F-XY-080-3	0324962	± 5	90	●

① Due to the interfering contour, monitoring of the gripper is not possible.

Tolerance compensation unit TCU

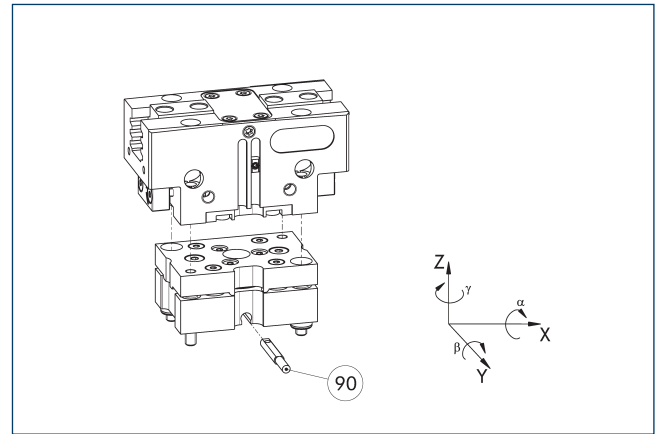

- ⑨⑩ Monitoring of locking

Grippers can be directly mounted without an adapter plate. Tolerance compensation unit and gripper have an identical screw connection diagram. Therefore the tolerance compensation units can be assembled later. Please consider the additional assembly height of the tolerance compensation unit. For details please refer to our catalog robot accessories.

Description	ID	Locking	Deflection	Often combined
Compensation unit				
TCU-P-125-3-MV	0324828	yes	±1°/±1,5°/±1,5°	●
TCU-P-125-3-OV	0324829	no	±1°/±1,5°/±1,5°	

Compact change system for grippers

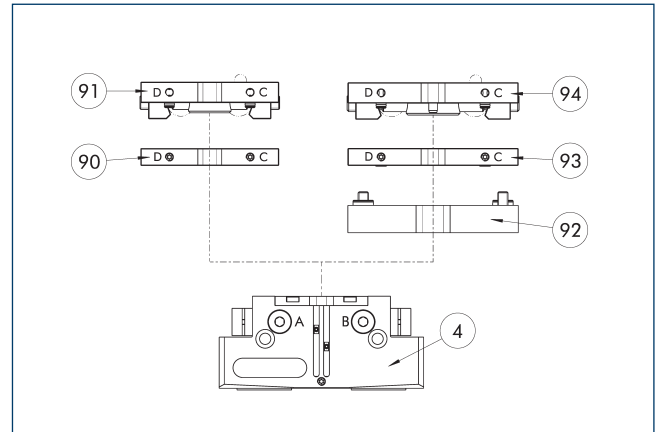

- ④ Grippers
- ⑨⑩ CWA compact change adapter
- ⑨① CWK compact change master
- ⑨② A-CWA adapter plate
- ⑨③ CWA compact change adapter
- ⑨④ CWK compact change master

Grippers can be directly mounted without an adapter plate. For details see our catalog Gripping or Robot Accessories.

Description	ID
CWA compact change adapter	
CWA-125-P	0305826
CWK compact change master	
CWK-125-P	0305825

Add-on valves for single grippers

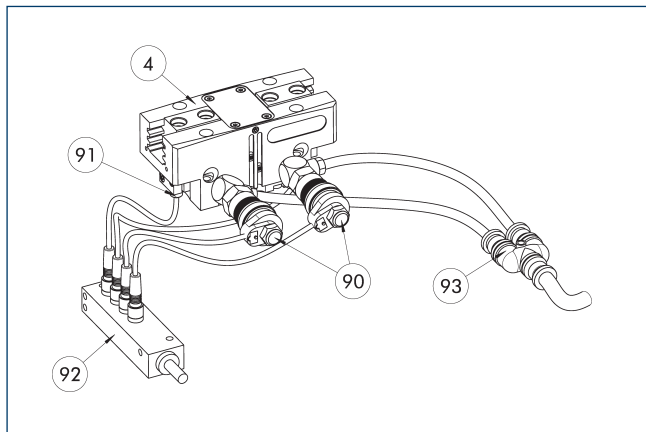

- ④ Grippers
- ⑨① Sensor
- ⑨② Sensor distributor
- ⑨③ Y distributor
- ⑨② Sensor distributor

The set of attachment valves reduces the compressed air consumption as there is no need to ventilate or bleed the supply lines. This can also reduce cycle time. The hose-free direct assembly of the micro valves reduces the hosing effort for the gripper. To further simplify electrical connection of the valves and sensors, their signals can be bundled via an optional distributor.

Description	ID	Often combined
Add-on valve set		
ABV-MV30-G1/8	0303328	
ABV-MV30-G1/8-V2-M8	0303396	
ABV-MV30-G1/8-V4-M8	0303366	●

① A set of add-on valves ABV is required per actuator. The ABV set contains two 3/2 micro valves, an Y-distributor for compressed air supply and optionally a sensor distributor with two or four inputs or outputs. Sensors for monitoring the gripper need to be ordered separately. Pneumatic hoses are not included in the scope of delivery.

Add-on valves for double grippers

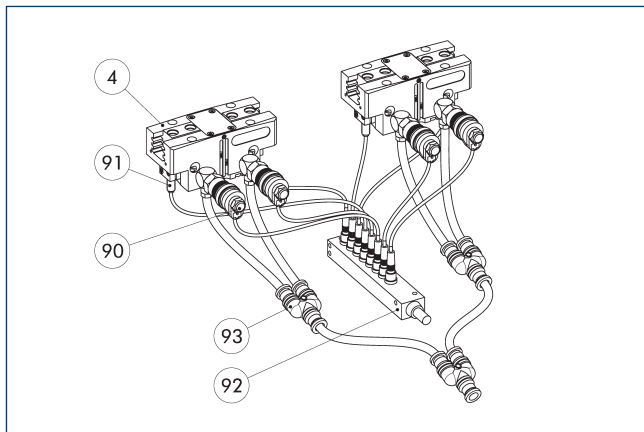

- ④ Grippers
- ⑨① Sensor
- ⑨② Sensor distributor
- ⑨③ Y distributor
- ⑨② Sensor distributor

The add-on valve set reduces compressed air consumption as there is no need to ventilate or bleed the supply lines. This can also reduce cycle time. The hose-free direct assembly of the micro valves reduces the hosing effort for the gripper. To further simplify electrical connection of the valves and sensors, their signals can be bundled via a distributor.

Description	ID
Add-on valve set	
ABV-MV30-G1/8-V8-M8	0303367

① A set of add-on valves ABV is required per double gripping unit. The ABV set contains four 3/2 microvalves, three Y-distributors for compressed air supply and a sensor distributor with eight inputs or outputs. Sensors for monitoring the gripper need to be ordered separately. Pneumatic hoses are not included in the scope of delivery.

Modular Assembly Automation

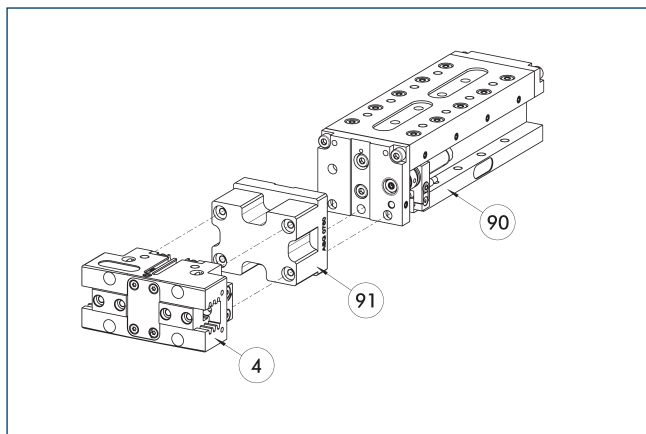

- ④ Grippers
- ⑨① ASG adapter plate
- ⑨② Linear module CLM/KLM/LM/ELP/ELM/ELS/HLM

Grippers and linear modules can be combined with standard adapter plates from the modular assembly system. For more information see our main catalog "Modular Assembly Automation".

PGN-plus-P 125

Universal gripper

Inductive proximity switches

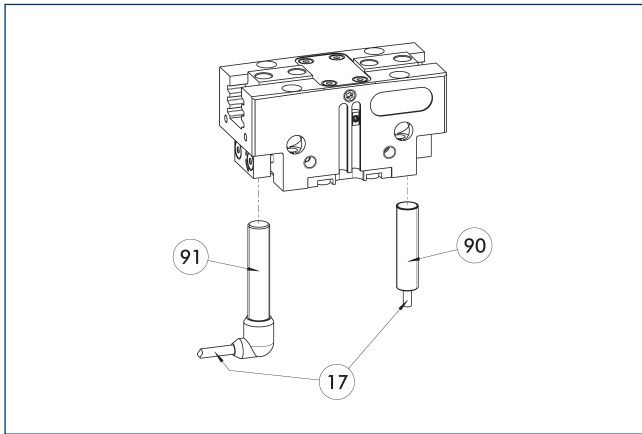

17 Cable outlet

91 Sensor IN..-SA

90 Sensor IN ...

Directly mounted end position monitoring.

Description	ID	Often combined
Inductive proximity switches		
IN 80-S-M12	0301578	
IN 80-S-M8	0301478	●
INK 80-S	0301550	
Inductive proximity switch with lateral cable outlet		
IN 80-S-M12-SA	0301587	
IN 80-S-M8-SA	0301483	●
INK 80-S-SA	0301566	
Connection cables		
KA BG08-L 3P-0300-PNP	0301622	●
KA BG08-L 3P-0500-PNP	0301623	
KA BG12-L 3P-0500-PNP	30016369	
KA BW08-L 3P-0300-PNP	0301594	
KA BW08-L 3P-0500-PNP	0301502	
KA BW12-L 3P-0300-PNP	0301503	
KA BW12-L 3P-0500-PNP	0301507	
Clip for connector/socket		
CLI-M12	0301464	
CLI-M8	0301463	
Cable extension		
KV BG12-SG12 3P-0030-PNP	0301999	
KV BG12-SG12 3P-0060-PNP	0301998	
KV BW08-SG08 3P-0030-PNP	0301495	
KV BW08-SG08 3P-0100-PNP	0301496	
KV BW08-SG08 3P-0200-PNP	0301497	●
KV BW12-SG12 3P-0030-PNP	0301595	
KV BW12-SG12 3P-0100-PNP	0301596	
KV BW12-SG12 3P-0200-PNP	0301597	
Sensor distributor		
V2-M12	0301776	●
V2-M8	0301775	●
V4-M8	0301746	
V8-M8	0301751	

① Two sensors are required per unit for monitoring two positions. On option, extension cables and sensor distributors are available. Additional product variants of the sensor, and further information and technical data can be found in the catalog chapter sensor system.

Flexible position sensor

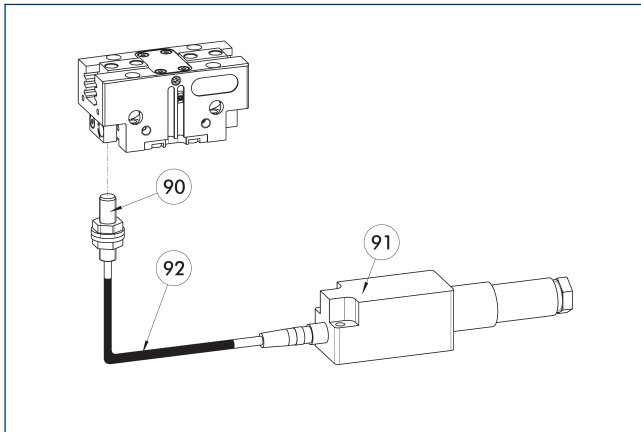

- ⑨⑩ FPS-S sensor
- ⑨② Cable extension
- ⑨① FPS-F5 evaluation electronic

Flexible position monitoring of up to five positions.

Description	ID	
Attachment kit for FPS		
AS-FPS-PGN-plus-P 125-1	1363894	
AS-FPS-PGN-plus-P 125-2	1366173	
Sensor		
FPS-S M8	0301704	
Evaluation electronics		
FPS-F5	0301805	
Cable extension		
KV BG08-SG08 3P-0050	0301598	
KV BG08-SG08 3P-0100	0301599	

- ① When using an FPS system, an FPS sensor (FPS-S) as well as an electronic processor (FPS-F5 / F5 T) are required for each gripper as well as a mounting kit (AS), if listed. Cable extensions (KV) are optionally available – see catalog chapter "Accessories."

Electronic magnetic switch MMS

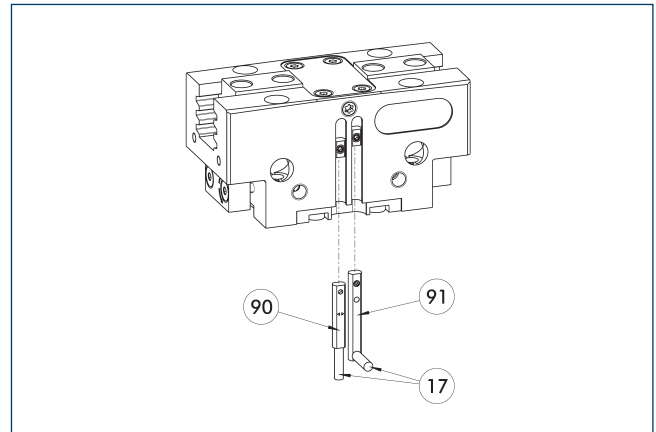

- ①⑦ Cable outlet
- ⑨① Sensor MMS 22...-SA
- ⑨⑩ Sensor MMS 22..

End position monitoring for mounting in the C-slot.

Description	ID	Often combined
Electronic magnetic switch		
MMS 22-S-M8-PNP	0301032	●
MMSK 22-S-PNP	0301034	
Electronic magnetic switches with lateral cable outlet		
MMS 22-S-M8-PNP-SA	0301042	●
MMSK 22-S-PNP-SA	0301044	
Connection cables		
KA BG08-L 3P-0300-PNP	0301622	●
KA BG08-L 3P-0500-PNP	0301623	
KA BW08-L 3P-0300-PNP	0301594	
KA BW08-L 3P-0500-PNP	0301502	
Clip for connector/socket		
CLI-M8	0301463	
Cable extension		
KV BW08-SG08 3P-0030-PNP	0301495	
KV BW08-SG08 3P-0100-PNP	0301496	
KV BW08-SG08 3P-0200-PNP	0301497	●
Sensor distributor		
V2-M8	0301775	●
V4-M8	0301746	
V8-M8	0301751	

- ① Two sensors are required per unit for monitoring two positions. On option, extension cables and sensor distributors are available. Additional product variants of the sensor, and further information and technical data can be found in the catalog chapter sensor system.

PGN-plus-P 125

Universal gripper

Programmable magnetic switch MMS 22-PI1

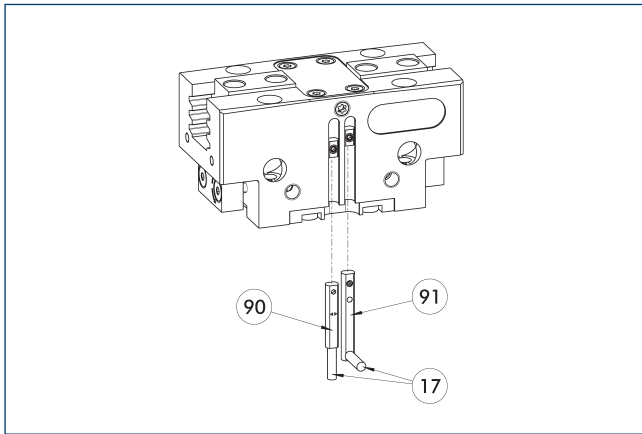

- ⑰ Cable outlet
- ⑨① Sensor MMS 22 ..-PI1-...-SA
- ⑨② Sensor MMS 22 PI1-...

Position monitoring with one programmable position per sensor and integrated electronic system in the sensor. Can be programmed using MT magnetic teaching tool (included in the scope of delivery, ID 0301030) or ST plug teaching tool (optional). End position monitoring for mounting in the C-slot. If the ST plug teaching tools are listed in the table provided, teaching is only possible with the ST teaching tools.

Description	ID	Often combined
Programmable magnetic switch		
MMS 22-PI1-S-M8-PNP	0301160	●
MMSK 22-PI1-S-PNP	0301162	
Programmable magnetic switch with lateral cable outlet		
MMS 22-PI1-S-M8-PNP-SA	0301166	●
MMSK 22-PI1-S-PNP-SA	0301168	
Programmable magnetic switch with stainless steel housing		
MMS 22-PI1-S-M8-PNP-HD	0301110	●
MMSK 22-PI1-S-PNP-HD	0301112	

- ① Two sensors are required per unit for monitoring two positions. On option, extension cables and sensor distributors are available. Additional product variants of the sensor, and further information and technical data can be found in the catalog chapter sensor system.

Programmable magnetic switch MMS 22-PI2

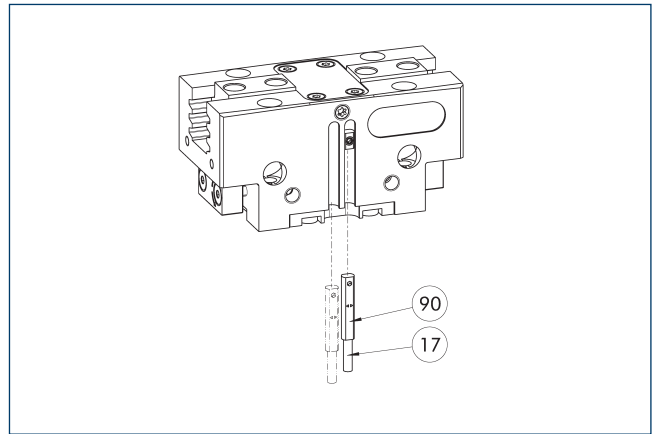

- ⑰ Cable outlet
- ⑨② MMS 22...-PI2-... sensor

Position monitoring with two programmable positions per sensor and electronics integrated in the sensor. Can be programmed using MT magnetic teaching tool (included in the scope of delivery, ID 0301030) or ST plug teaching tool (optional). End position monitoring for mounting in the C-slot. If the ST plug teaching tools are listed in the table provided, teaching is only possible with the ST teaching tools.

Description	ID	Often combined
Programmable magnetic switch		
MMS 22-PI2-S-M8-PNP	0301180	●
MMSK 22-PI2-S-PNP	0301182	
Programmable magnetic switch with lateral cable outlet		
MMS 22-PI2-S-M8-PNP-SA	0301186	●
MMSK 22-PI2-S-PNP-SA	0301188	
Programmable magnetic switch with stainless steel housing		
MMS 22-PI2-S-M8-PNP-HD	0301130	●
MMSK 22-PI2-S-PNP-HD	0301132	

- ① One sensor is required per unit for monitoring two positions. Extension cables and sensor distributors are optionally available. Additional product variants of the sensor, and further information and technical data can be found in the catalog chapter sensor systems.

MMS-P programmable magnetic switch

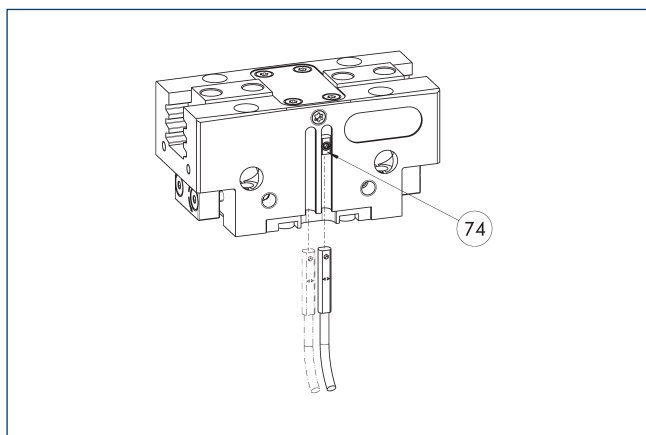

74 Limit stop for sensor

Position monitoring with two programmable positions per sensor. End position monitoring for mounting in the C-slot.

Description	ID	Often combined
Programmable magnetic switch		
MMSK-P 22-S-PNP	0301371	
MMS-P 22-S-M8-PNP	0301370	●
Connection cables		
KA GLN0804-LK-00500-A	0307767	●
KA GLN0804-LK-01000-A	0307768	
KA WLN0804-LK-00500-A	0307765	
KA WLN0804-LK-01000-A	0307766	
Clip for connector/socket		
CLI-M8	0301463	
Sensor distributor		
V2-M8-4P-2XM8-3P	0301380	

- ① One sensor is required per unit for monitoring two positions. Extension cables and sensor distributors are optionally available. Additional product variants of the sensor, and further information and technical data can be found in the catalog chapter sensor systems.

Analog position sensor MMS-A

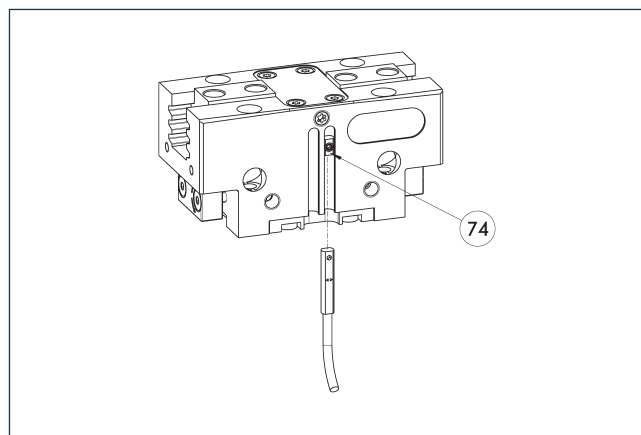

74 Limit stop for sensor

Non-contact measuring, analog multi-position monitoring for any number of positions, easy to assemble in the C-slot. Can be programmed using MT magnetic teaching tool (included in the scope of delivery, ID 0301030) or ST plug teaching tool (optional). End position monitoring for mounting in the C-slot. If the ST plug teaching tools are listed in the chart provided, teaching is only possible with the ST teaching tools.

Description	ID	
Analog position sensor		
MMS 22-A-10V-M08	0315825	
MMS 22-A-10V-M12	0315828	

- ① One sensor is required for each gripper. No additional mounting kit is required – the gripper is equipped for use of the sensor by default. Further information and technical data can be found in the catalog chapter sensor systems.

PGN-plus-P 125

Universal gripper

Flexible position sensor with MMS-A

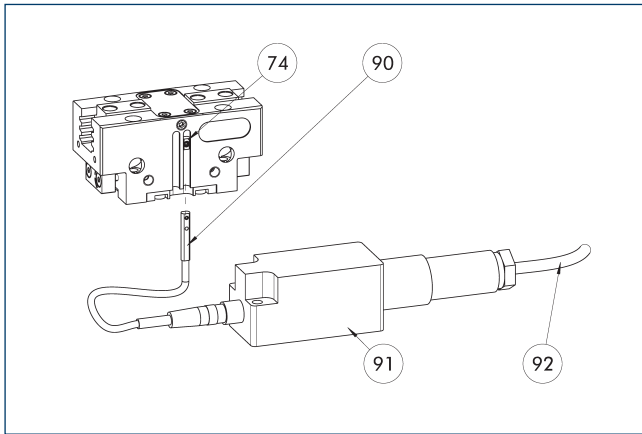

- 74 Limit stop for sensor
- 90 MMS 22-A-... sensor
- 91 FPS-F5 evaluation electronic
- 92 Connection cables

Flexible position monitoring of up to five positions. Sensor can be taught using MT magnetic teaching tool (included in the scope of delivery, ID 0301030) or ST plug teaching tool (optional). If the ST plug teaching tools are listed in the table provided, teaching is only possible with the ST teaching tools.

Description	ID	
Analog position sensor		
MMS 22-A-05V-M08	0315805	
Evaluation electronics		
FPS-F5	0301805	
Sensor Teaching Tool		
MT-MMS 22-PI	0301030	
Connection cables		
KA BG16-L 12P-1000	0301801	

- ① When using an FPS system, one MMS 22-A-05V and one evaluation electronics (FPS-F5) are required per each gripper, as well as an attachment kit (AS), if listed. On option, cable extensions (KV) are available – see catalog chapter “Accessories.”

Programmable magnetic switch MMS-IO-Link

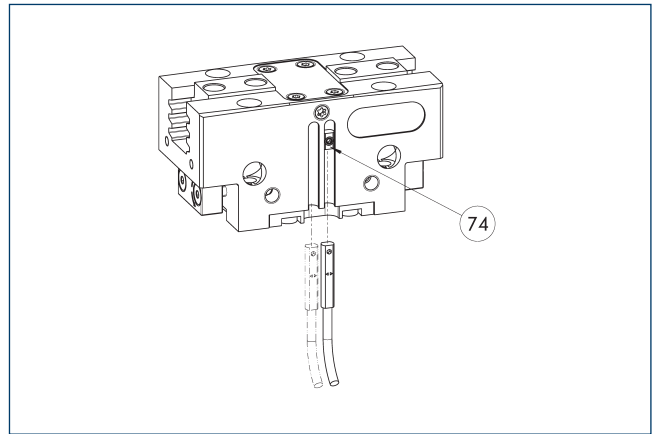

- 74 Limit stop for sensor

Sensor for multi-position monitoring through detection of the complete gripper stroke. The sensor is mounted directly in the C-slot of the gripper. The sensor is programmed for the gripper via the IO-Link interface, Magnet teaching tool MT (included in scope of delivery; ID 0301030) or the ST plug teaching tool (not included in scope of delivery; ID 0301026). An IO-Link master is required for operation.

Description	ID	
Programmable magnetic switch		
MMS 22-IO-L-M08	0315830	
MMS 22-IO-L-M12	0315835	

- ① One sensor is required for each gripper. No additional mounting kit is required – the gripper is equipped for use of the sensor by default. Further information and technical data can be found in the catalog chapter sensor systems.

APS-Z80 analog position sensor

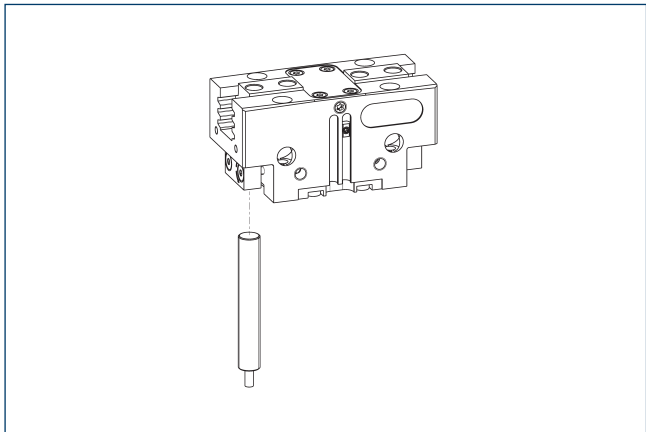

Non-contact measuring, analog multi-position monitoring for any number of positions.

Description	ID	Often combined
Mounting kit for APS-Z80		
AS-APS-Z80-PGN-plus-P 125-1	1366226	
AS-APS-Z80-PGN-plus-P 125-2	1366228	
Analog position sensor		
APS-Z80-K	0302072	
APS-Z80-M8	0302070	●

- ① When using an APS system, one mounting kit (AS-APS-Z80) and one APS-Z80 sensor is required per gripper. The resolution of the sensor can be lower in the peripheral areas of the gripper. You can find further information on the product in the operating manual.

APS-M1 analog position sensor

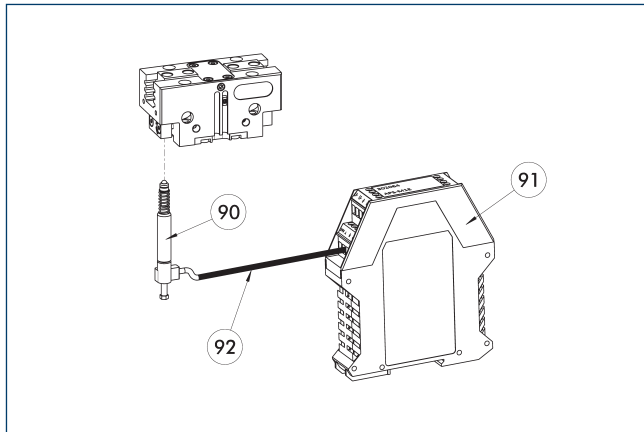

- ⑨⑩ APS-M1S sensor
- ⑨① APS-M1E electronic processor
- ⑨② APS-K extension cable

Analog multi position monitoring for any desired positions

Description	ID	
Mounting kit for APS-M1		
AS-APS-M1-PGN-plus-P 125-1	1363743	
AS-APS-M1-PGN-plus-P 125-2	1363745	
Analog position sensor		
APS-M1S	0302062	
Connection cables		
APS-K0200	0302066	
APS-K0700	0302068	
Evaluation electronics		
APS-M1E	0302064	

- ① When using an APS system, for each gripper an attachment kit (AS-APS-M1), an APS-M1S sensor (incl. 3 m cable) as well as an electronics (APS-M1e) are required. An extension cable (APS-K) can be connected between the sensor and the electronics as an option. The max. cable length between the sensor and the electronics is 10 m, between the electronics and their control unit (PLC) it is max. 1 m.

PGN-plus-P 160

Universal gripper



Gripping force O.D. gripping

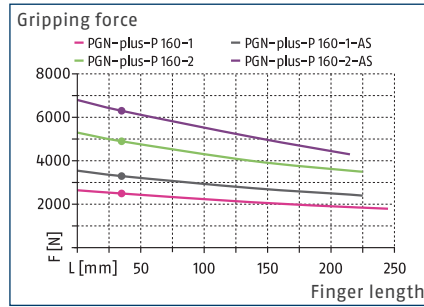

Gripping force I.D. gripping

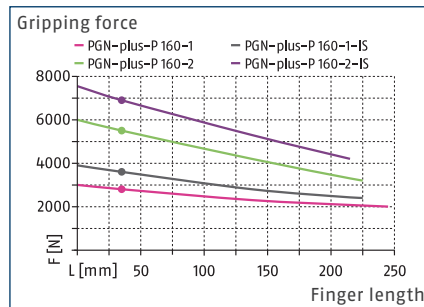

Dimensions and maximum loads

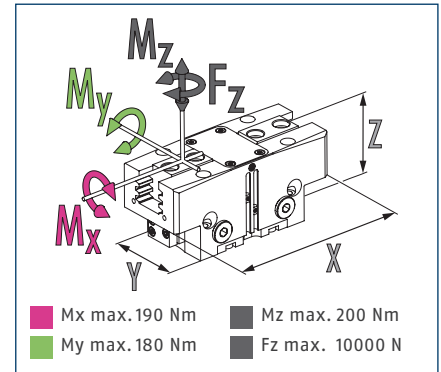

① The indicated moments and forces are static values, apply for each base jaw and may appear simultaneously. Loads may additionally occur to the moment produced by the gripping force itself.

Technical data

Description		PGN-plus-P 160-1	PGN-plus-P 160-2	PGN-plus-P 160-1-AS	PGN-plus-P 160-2-AS	PGN-plus-P 160-1-IS	PGN-plus-P 160-2-IS
ID		0318592	0318593	0318594	0318595	0318596	0318597
Stroke per jaw	[mm]	16	8	16	8	16	8
Closing/opening force	[N]	2500/2800	4900/5500	3300/-	6300/-	-/3600	-/6900
Min. spring force	[N]			800	1400	800	1400
Weight	[kg]	2.8	2.9	3.6	3.7	3.5	3.7
Recommended workpiece weight	[kg]	12.5	24.5	12.5	24.5	12.5	24.5
Fluid consumption double stroke	[cm³]	200	200	355	355	380	380
Min./nom./max. operating pressure	[bar]	2.5/6/8	2.5/6/8	4/6/6.5	4/6/6.5	4/6/6.5	4/6/6.5
Min./max. air purge pressure	[bar]	0.5/1	0.5/1	0.5/1	0.5/1	0.5/1	0.5/1
Closing/opening time	[s]	0.1/0.1	0.1/0.1	0.1/0.2	0.1/0.2	0.2/0.1	0.2/0.1
Closing/opening time with spring	[s]			0.20	0.20	0.20	0.20
Max. permissible finger length	[mm]	245	225	225	215	225	215
Max. permissible weight per finger	[kg]	3.8	3.8	3.8	3.8	3.8	3.8
IP protection class		40	40	40	40	40	40
Min./max. ambient temperature	[°C]	5/90	5/90	5/90	5/90	5/90	5/90
Repeat accuracy	[mm]	0.01	0.01	0.01	0.01	0.01	0.01
Dimensions X x Y x Z	[mm]	192 x 72 x 77	192 x 72 x 77	192 x 72 x 117	192 x 72 x 117	192 x 72 x 117	192 x 72 x 117
Options and their characteristics							
Dustproof version		1317645	1317647	1317649	1317652	1317653	1317654
IP protection class		64	64	64	64	64	64
Weight	[kg]	3.2	3.2	4	4	4	4
Corrosion-protected version		1317631	1317632	1317638	1317639	1317641	1317644
High-temperature version		1317594	1317596	1317599	1317600	1317625	1317629
Min./max. ambient temperature	[°C]	5/130	5/130	5/130	5/130	5/130	5/130
Precision version		1317656	1317659	1317658	1317660		

① It may take a few 100 gripping cycles until the full gripping force (as indicated in the data table) will be available.

Main view

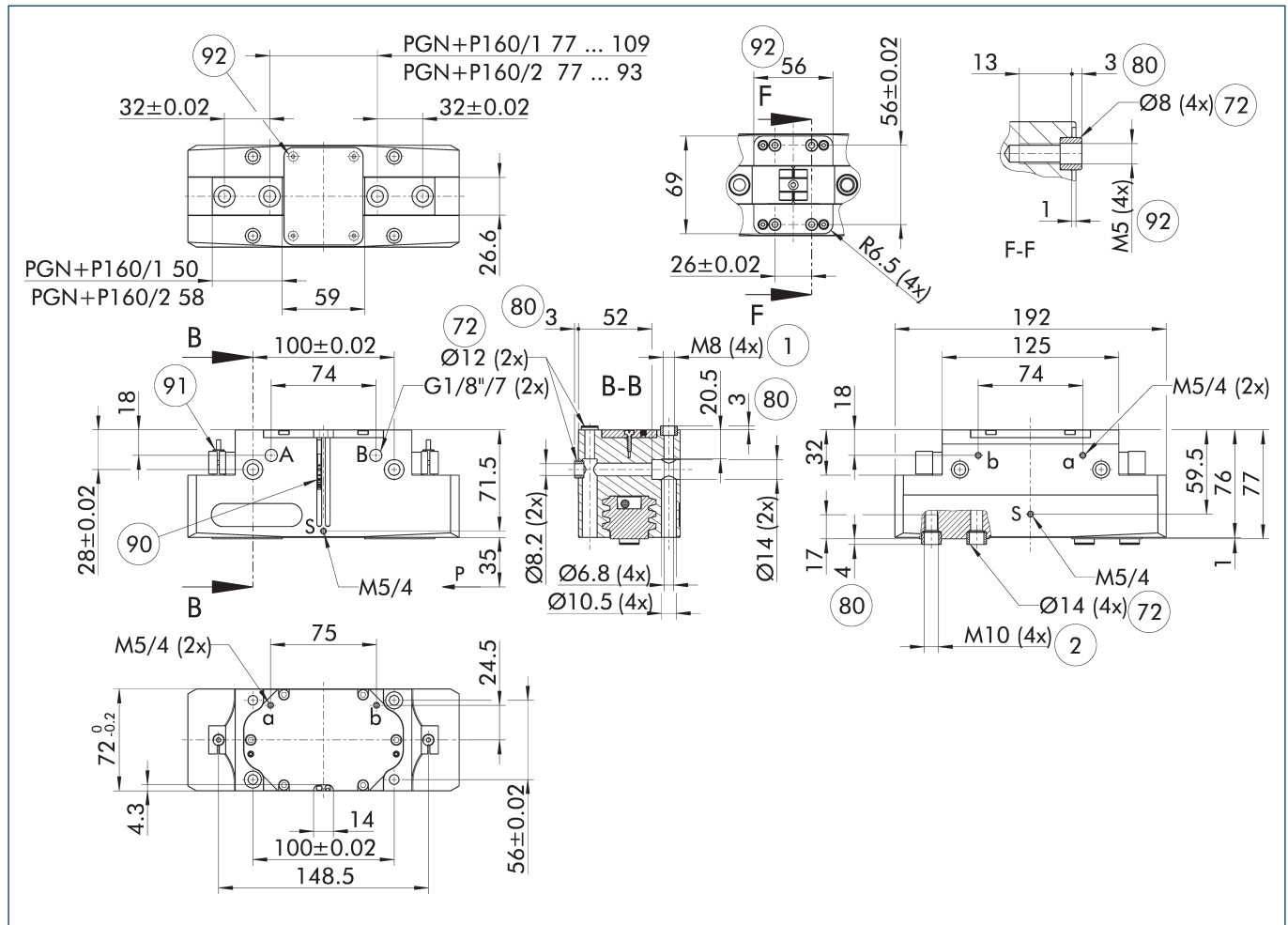

The drawing shows the gripper in the basic version with closed jaws, without dimensional consideration of the options described below.

① As an alternative/in addition to spring-assisted mechanical gripping force maintenance, the SDV-P pressure maintenance valve can be used for I.D. and O.D. gripping (see "Accessories" section of catalog).

- A, a Main / direct connection, gripper opening
- B, b Main / direct connection, gripper closing
- S Air purge connection
- ① Gripper connection
- ② Finger connection
- ⑦ Fit for centering sleeves

- ⑧ Depth of the centering sleeve hole in the counter part
- ⑨ Sensor MMS 22..
- ⑩ Sensor IN ...
- ⑪ Screw connection with centering for customized mounting (these centering sleeves are not included in the scope of delivery)

PGN-plus-P 160

Universal gripper

Maximum permitted finger projection

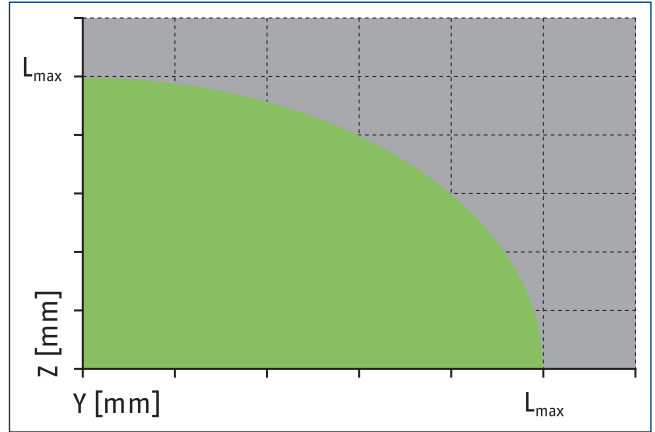
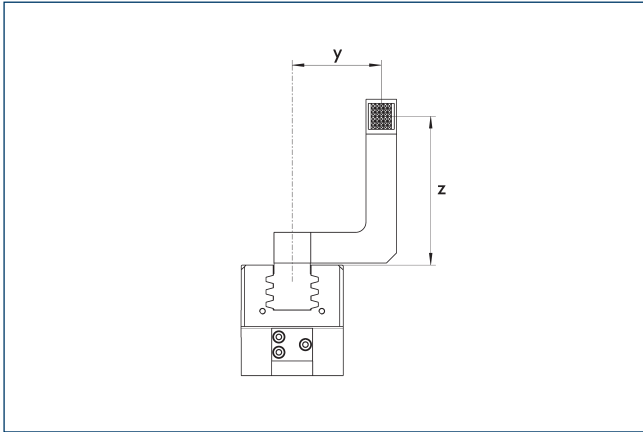

■ Permitted range ■ Inadmissible range
 L^{max} is equivalent to the maximum permitted finger length, see the technical data table.

Hose-free direct connection M5

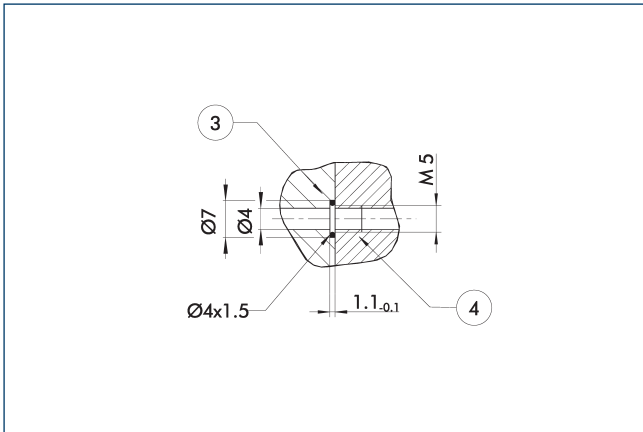

③ Adapter ④ Grippers

The direct connection is used for supplying compressed air without hoses. Instead, the pressure medium is fed through bore-holes in the mounting plate.

Gripping force maintenance version AS/IS

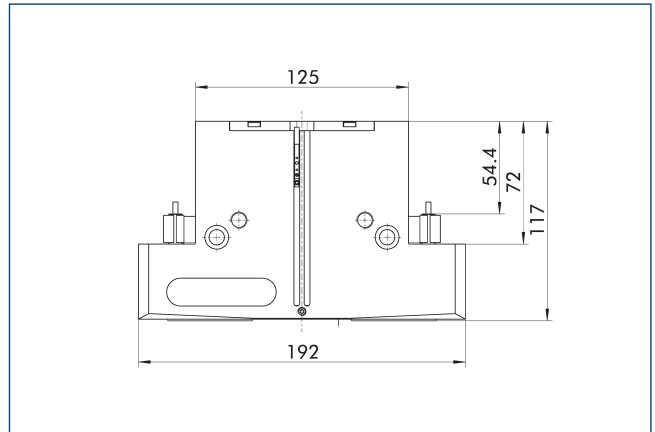

The mechanical gripping force maintenance device ensures that a minimum clamping force will be applied even if there is a drop in pressure. In the AS/S variant this acts as a closing force, in the IS variant as an opening force. Besides this, gripping force maintenance can be used to increase gripping force or for single actuated gripping.

SDV-P pressure maintenance valve

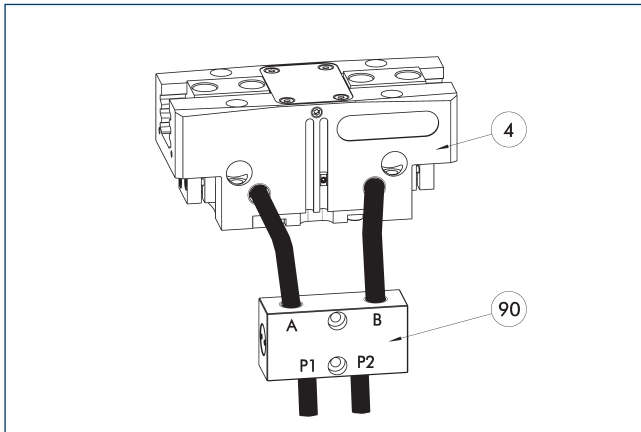

④ Grippers

⑨⑩ SDV-P pressure maintenance valve

The SDV-P pressure maintenance valve ensures in emergency STOP situations that the pressure in the piston chamber of pneumatic gripper, swivel, linear, and quick-change modules is temporarily maintained.

Description	ID	Recommended hose diameter [mm]
Pressure maintenance valve		
SDV-P 07	0403131	8
Pressure maintenance valve with air bleed screw		
SDV-P 07-E	0300121	8
SDV-P 10-E	0300109	10

① In order to achieve the specified closing and opening time for each gripper variant, the recommended hose diameter must be used. The direct allocation of the respective variant of the gripper for the respective SDV-P can be found at schunk.com.

Pneumatic positioning device PPD

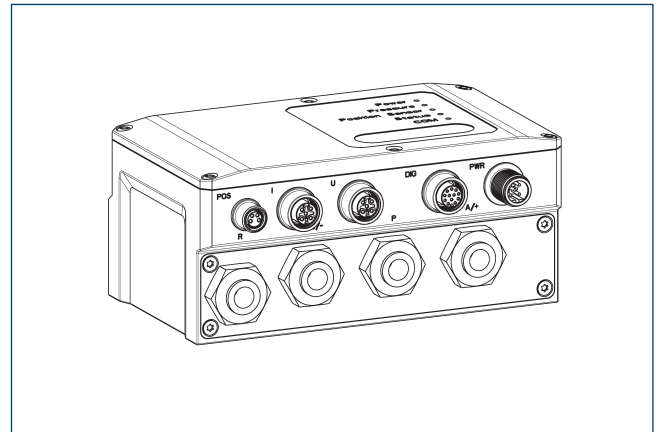

The PPD allows flexibility in all applications with pneumatic grippers through free positioning, gripping force and speed adjustment.

Description	ID	
Pneumatic positioning device		
PPD 20-IOL	1540700	
Adapter		
A GGN0804-1204-A	1540691	
IO-Link connection cable		
KA GGN1205-1212-IOL-00100-A	1540697	
Voltage supply connection cable - cable track compatible		
KA GLN12B05-LK-01000-A	1540660	
Cable extension		
KV GGN0804-IO-00150-A	1540662	
KV GGN0804-IO-00300-A	1540663	
Assembly set		
Assembly set PPD	1540705	

① In addition to the PPD, a position sensor (SCHUNK IO-Link sensor or analog sensor (4...20 mA)) is required.

Protective cover HUE PGN-plus 160

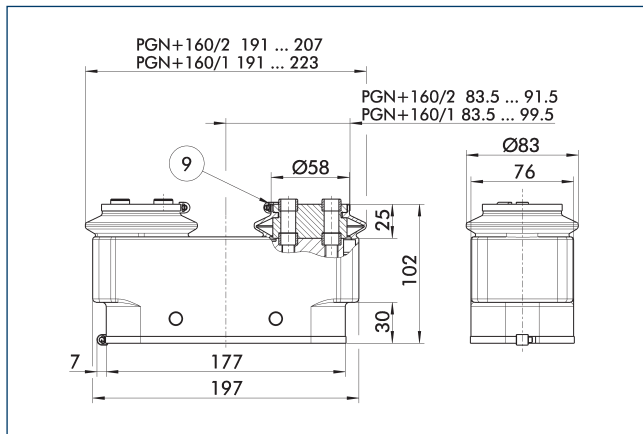

⑨ For mounting screw connection diagram, see basic version

The HUE protective cover fully protects the gripper against external influences. The cover is suitable for applications of up to IP65 if an additional sealing of the cover bottom is provided. For detailed information, please see the HUE series. The connection diagram shifts by the height of the intermediate jaw.

Description	ID	IP protection class
Protection cover		
HUE PGN-plus 160	0371484	65

① The HUE protective cover is not suitable for use on grippers with gripping force maintenance. An inductive monitoring of the gripper in connection with the HUE protective cover is not possible. SCHUNK recommends the use of magnetic sensors that are approved for the respective gripper variant.

BSWS jaw quick-change jaw systems

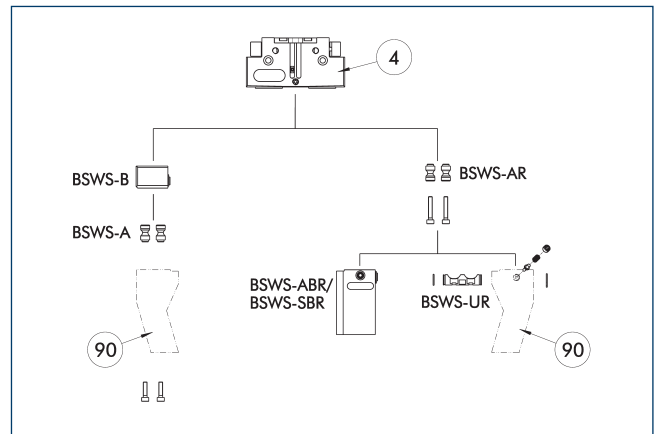

④ Grippers

⑨ Customized gripper fingers

There are various jaw quick-change systems available for the gripper. For detailed information, please refer to the corresponding product.

Description	ID	Scope of delivery
Jaw quick-change system adapter pin		
BSWS-A 160	0303030	2
BSWS-AR 160	0300096	2
Quick-change jaw system base		
BSWS-B 160	0303031	1
Jaw quick-change system finger blank		
BSWS-ABR-PGZN-plus 160	0300076	1
BSWS-SBR-PGZN-plus 160	0300086	1
Jaw quick-change system locking mechanism		
BSWS-UR 160	0302995	1

① If the operating pressure is higher than 6 bar, suitability for use beyond the application limits must be checked. Only systems that are listed in the table, can be used.

Fields of application

Series	Size	Variant	Suitability
PGN-plus-P	160	-1 (6 bar)	■■■■■
PGN-plus-P	160	-1-AS/1-IS (6 bar)	■■■■■
PGN-plus-P	160	-2 (6 bar)	■■■□□
PGN-plus-P	160	-2-AS/2-IS (6 bar)	■■■□□
Legend			
■■■■■	Can be combined without restrictions		
■■■□□	Use with restrictions (see loading limits)		
□□□□	cannot be combined		

The load limits for describing the application limits can be found in the catalog chapter of the corresponding accessories.

PGN-plus-P 160

Universal gripper

Jaw quick-change system BSWs-M

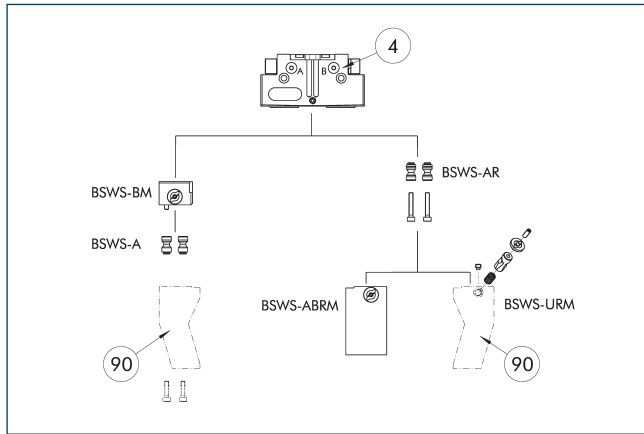

- ④ Grippers
- ⑨⑩ Customized gripper fingers

There are various jaw quick-change systems available for the gripper. For detailed information, please refer to the corresponding product.

Description	ID	Scope of delivery
Jaw quick-change system adapter pin		
BSWS-A 160	0303030	2
BSWS-AR 160	0300096	2
Quick-change jaw system base		
BSWS-BM 160	1418962	1
Jaw quick-change system finger blank		
BSWS-ABRM-PGZN-plus 160	1420855	1
Jaw quick-change system locking mechanism		
BSWS-URM 160	1420541	1

① If the operating pressure is higher than 6 bar, suitability for use beyond the application limits must be checked. Only systems that are listed in the table, can be used.

Fields of application

Series	Size	Variant	Suitability
PGN-plus-P	160	-1 (6 bar)	■■■■■
PGN-plus-P	160	-1-AS/1-IS (6 bar)	■■■■■
PGN-plus-P	160	-2 (6 bar)	■■■□□
PGN-plus-P	160	-2-AS/2-IS (6 bar)	■■■□□
Legend			
■■■■■	Can be combined without restrictions		
■■■□□	Use with restrictions (see loading limits)		
□□□□	cannot be combined		

The load limits for describing the application limits can be found in the catalog chapter of the corresponding accessories.

ZBA-L-plus 160 intermediate jaws

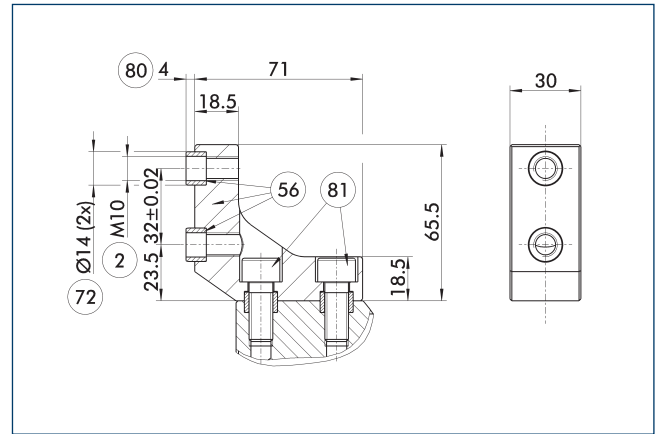

- ② Finger connection
- ⑤⑥ Included in the scope of delivery
- ⑦② Fit for centering sleeves
- ⑧⑩ Depth of the centering sleeve hole in the counter part
- ⑧① Not included in the scope of delivery

The optional ZBA-L-plus intermediate jaws allow the screw connection diagram of the top jaws to be rotated by 90°. This makes it easier to design and produce top jaws (particularly for long versions) because no deep through-bores are required.

Description	ID	Material	Finger interface	Scope of delivery
Intermediate jaw				
ZBA-L-plus 160	0311762	Aluminum	PGN-plus 160	1

PGN-plus-P 160

Universal gripper

Tolerance compensation unit TCU

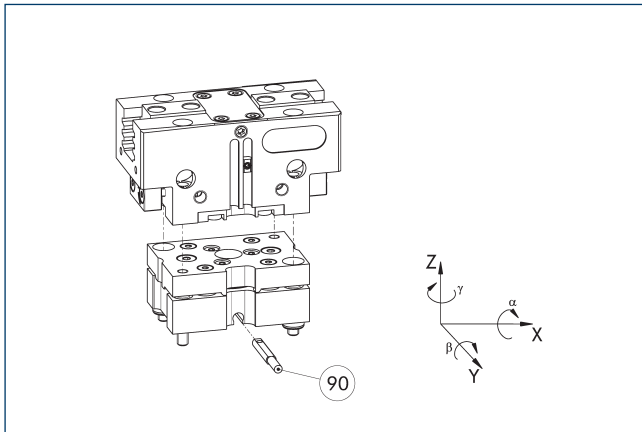

⑨⑩ Monitoring of locking

Grippers can be directly mounted without an adapter plate. Tolerance compensation unit and gripper have an identical screw connection diagram. Therefore the tolerance compensation units can be assembled later. Please consider the additional assembly height of the tolerance compensation unit. For details please refer to our catalog robot accessories.

Description	ID	Locking	Deflection	Often combined
Compensation unit				
TCU-P-160-3-MV	0324846	yes	$\pm 1^\circ / \pm 2^\circ / \pm 1,5^\circ$	●
TCU-P-160-3-0V	0324847	no	$\pm 1^\circ / \pm 2^\circ / \pm 1,5^\circ$	

Add-on valves for single grippers

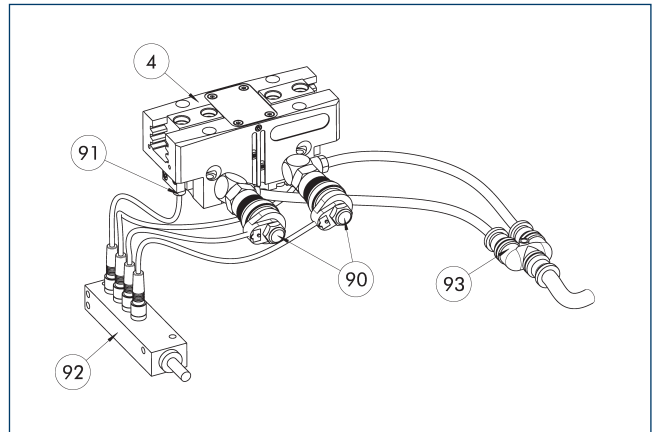

- ④ Grippers
- ⑨⑩ Micro valves
- ⑨① Sensor
- ⑨② Sensor distributor
- ⑨③ Y distributor

The set of attachment valves reduces the compressed air consumption as there is no need to ventilate or bleed the supply lines. This can also reduce cycle time. The hose-free direct assembly of the micro valves reduces the hosing effort for the gripper. To further simplify electrical connection of the valves and sensors, their signals can be bundled via an optional distributor.

Description	ID	Often combined
Add-on valve set		
ABV-MV30-G1/8	0303328	
ABV-MV30-G1/8-V2-M8	0303396	
ABV-MV30-G1/8-V4-M8	0303366	●

- ① A set of add-on valves ABV is required per actuator. The ABV set contains two 3/2 micro valves, an Y-distributor for compressed air supply and optionally a sensor distributor with two or four inputs or outputs. Sensors for monitoring the gripper need to be ordered separately. Pneumatic hoses are not included in the scope of delivery.

Add-on valves for double grippers

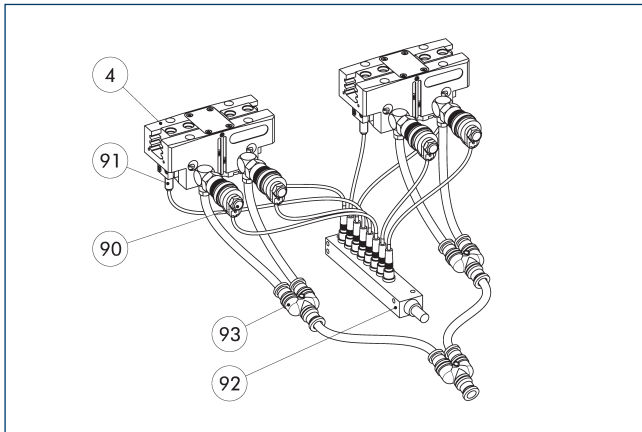

- ④ Grippers
- ⑨② Sensor distributor
- ⑨① Micro valves
- ⑨③ Y distributor
- ⑨① Sensor

The add-on valve set reduces compressed air consumption as there is no need to ventilate or bleed the supply lines. This can also reduce cycle time. The hose-free direct assembly of the micro valves reduces the hosing effort for the gripper. To further simplify electrical connection of the valves and sensors, their signals can be bundled via a distributor.

Description	ID
Add-on valve set	
ABV-MV30-G1/8-V8-M8	0303367

- ① A set of add-on valves ABV is required per double gripping unit. The ABV set contains four 3/2 microvalves, three Y-distributors for compressed air supply and a sensor distributor with eight inputs or outputs. Sensors for monitoring the gripper need to be ordered separately. Pneumatic hoses are not included in the scope of delivery.

Modular Assembly Automation

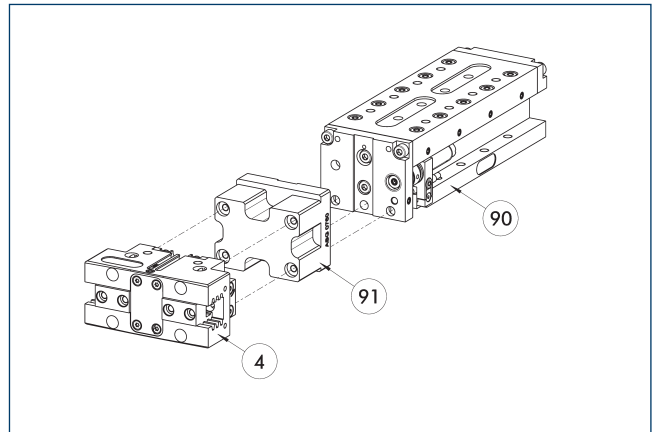

- ④ Grippers
- ⑨① ASG adapter plate
- ⑨① Linear module CLM/KLM/LM/ELP/ELM/ELS/HLM

Grippers and linear modules can be combined with standard adapter plates from the modular assembly system. For more information see our main catalog "Modular Assembly Automation".

PGN-plus-P 160

Universal gripper

Inductive proximity switches

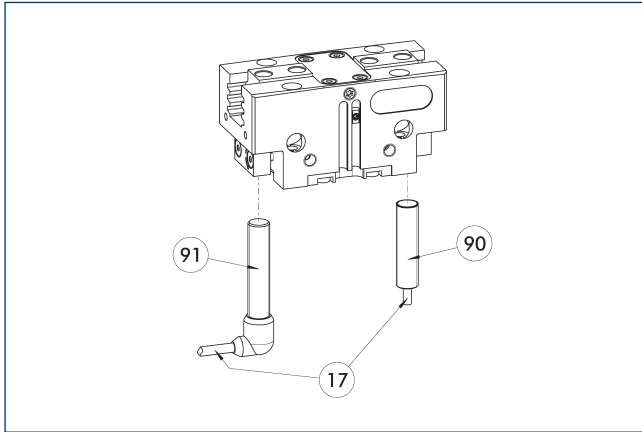

- 17 Cable outlet
- 90 Sensor IN ...
- 91 Sensor IN..-SA

Directly mounted end position monitoring.

Description	ID	Often combined
Inductive proximity switches		
IN 80-S-M12	0301578	
IN 80-S-M8	0301478	●
INK 80-S	0301550	
Inductive proximity switch with lateral cable outlet		
IN 80-S-M12-SA	0301587	
IN 80-S-M8-SA	0301483	●
INK 80-S-SA	0301566	
Connection cables		
KA BG08-L 3P-0300-PNP	0301622	●
KA BG08-L 3P-0500-PNP	0301623	
KA BG12-L 3P-0500-PNP	30016369	
KA BW08-L 3P-0300-PNP	0301594	
KA BW08-L 3P-0500-PNP	0301502	
KA BW12-L 3P-0300-PNP	0301503	
KA BW12-L 3P-0500-PNP	0301507	
Clip for connector/socket		
CLI-M12	0301464	
CLI-M8	0301463	
Cable extension		
KV BG12-SG12 3P-0030-PNP	0301999	
KV BG12-SG12 3P-0060-PNP	0301998	
KV BW08-SG08 3P-0030-PNP	0301495	
KV BW08-SG08 3P-0100-PNP	0301496	
KV BW08-SG08 3P-0200-PNP	0301497	●
KV BW12-SG12 3P-0030-PNP	0301595	
KV BW12-SG12 3P-0100-PNP	0301596	
KV BW12-SG12 3P-0200-PNP	0301597	
Sensor distributor		
V2-M12	0301776	●
V2-M8	0301775	●
V4-M8	0301746	
V8-M8	0301751	

- ① Two sensors are required per unit for monitoring two positions. On option, extension cables and sensor distributors are available. Additional product variants of the sensor, and further information and technical data can be found in the catalog chapter sensor system.

Flexible position sensor

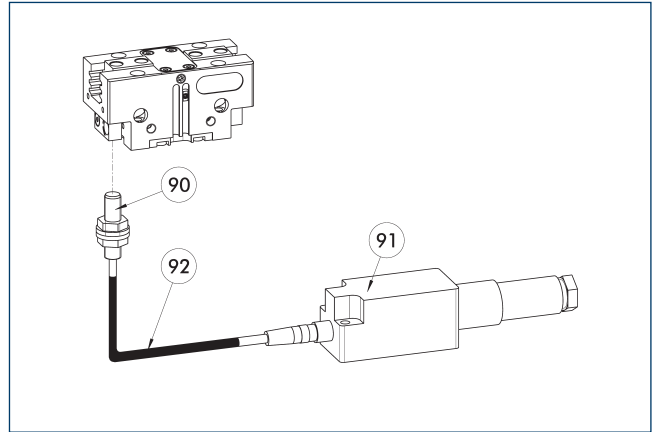

- 90 FPS-S sensor
- 91 FPS-F5 evaluation electronic
- 92 Cable extension

Flexible position monitoring of up to five positions.

Description	ID	
Attachment kit for FPS		
AS-FPS-PGN-plus-P 160-1	1388823	
AS-FPS-PGN-plus-P 160-2	1388826	
Sensor		
FPS-S M8	0301704	
Evaluation electronics		
FPS-F5	0301805	
Cable extension		
KV BG08-SG08 3P-0050	0301598	
KV BG08-SG08 3P-0100	0301599	

- ① When using an FPS system, an FPS sensor (FPS-S) as well as an electronic processor (FPS-F5 / F5 T) are required for each gripper as well as a mounting kit (AS), if listed. Cable extensions (KV) are optionally available – see catalog chapter "Accessories."

Electronic magnetic switch MMS

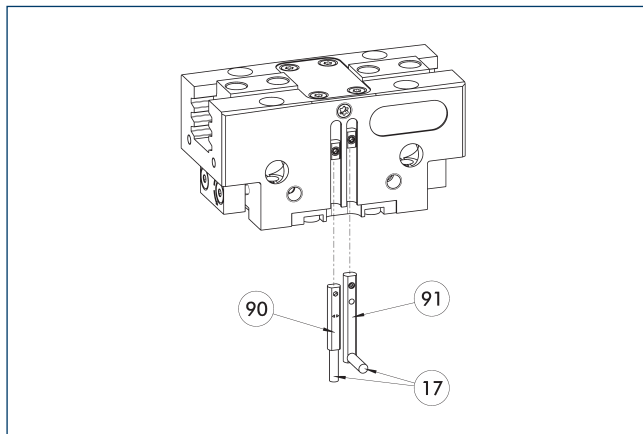

- ①7 Cable outlet
- ①91 Sensor MMS 22...-SA
- ①90 Sensor MMS 22..

End position monitoring for mounting in the C-slot.

Description	ID	Often combined
Electronic magnetic switch		
MMS 22-S-M8-PNP	0301032	●
MMSK 22-S-PNP	0301034	
Electronic magnetic switches with lateral cable outlet		
MMS 22-S-M8-PNP-SA	0301042	●
MMSK 22-S-PNP-SA	0301044	
Connection cables		
KA BG08-L 3P-0300-PNP	0301622	●
KA BG08-L 3P-0500-PNP	0301623	
KA BW08-L 3P-0300-PNP	0301594	
KA BW08-L 3P-0500-PNP	0301502	
Clip for connector/socket		
CLI-M8	0301463	
Cable extension		
KV BW08-SG08 3P-0030-PNP	0301495	
KV BW08-SG08 3P-0100-PNP	0301496	
KV BW08-SG08 3P-0200-PNP	0301497	●
Sensor distributor		
V2-M8	0301775	●
V4-M8	0301746	
V8-M8	0301751	

- ① Two sensors are required per unit for monitoring two positions. On option, extension cables and sensor distributors are available. Additional product variants of the sensor, and further information and technical data can be found in the catalog chapter sensor system.

Programmable magnetic switch MMS 22-PI1

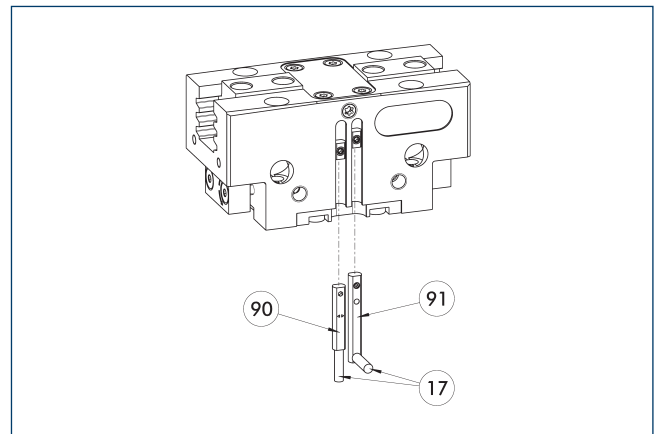

- ①7 Cable outlet
- ①91 Sensor MMS 22 ..-PI1-...-SA
- ①90 Sensor MMS 22 PI1-...

Position monitoring with one programmable position per sensor and integrated electronic system in the sensor. Can be programmed using MT magnetic teaching tool (included in the scope of delivery, ID 0301030) or ST plug teaching tool (optional). End position monitoring for mounting in the C-slot. If the ST plug teaching tools are listed in the table provided, teaching is only possible with the ST teaching tools.

Description	ID	Often combined
Programmable magnetic switch		
MMS 22-PI1-S-M8-PNP	0301160	●
MMSK 22-PI1-S-PNP	0301162	
Programmable magnetic switch with lateral cable outlet		
MMS 22-PI1-S-M8-PNP-SA	0301166	●
MMSK 22-PI1-S-PNP-SA	0301168	
Programmable magnetic switch with stainless steel housing		
MMS 22-PI1-S-M8-PNP-HD	0301110	●
MMSK 22-PI1-S-PNP-HD	0301112	

- ① Two sensors are required per unit for monitoring two positions. On option, extension cables and sensor distributors are available. Additional product variants of the sensor, and further information and technical data can be found in the catalog chapter sensor system.

PGN-plus-P 160

Universal gripper

Programmable magnetic switch MMS 22-PI2

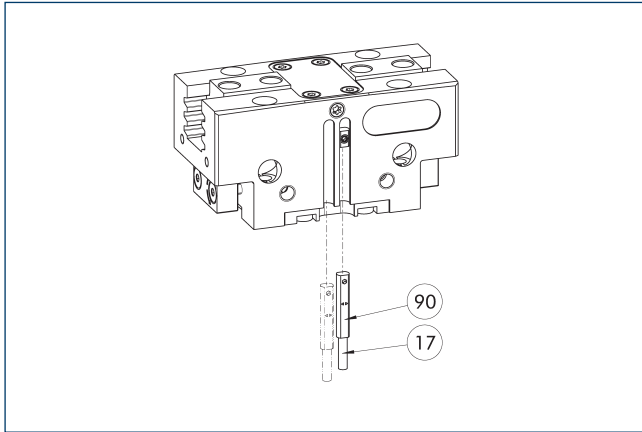

17 Cable outlet

90 MMS 22...-PI2-... sensor

Position monitoring with two programmable positions per sensor and electronics integrated in the sensor. Can be programmed using MT magnetic teaching tool (included in the scope of delivery, ID 0301030) or ST plug teaching tool (optional). End position monitoring for mounting in the C-slot. If the ST plug teaching tools are listed in the table provided, teaching is only possible with the ST teaching tools.

Description	ID	Often combined
Programmable magnetic switch		
MMS 22-PI2-S-M8-PNP	0301180	●
MMSK 22-PI2-S-PNP	0301182	
Programmable magnetic switch with lateral cable outlet		
MMS 22-PI2-S-M8-PNP-SA	0301186	●
MMSK 22-PI2-S-PNP-SA	0301188	
Programmable magnetic switch with stainless steel housing		
MMS 22-PI2-S-M8-PNP-HD	0301130	●
MMSK 22-PI2-S-PNP-HD	0301132	

- ① One sensor is required per unit for monitoring two positions. Extension cables and sensor distributors are optionally available. Additional product variants of the sensor, and further information and technical data can be found in the catalog chapter sensor systems.

MMS-P programmable magnetic switch

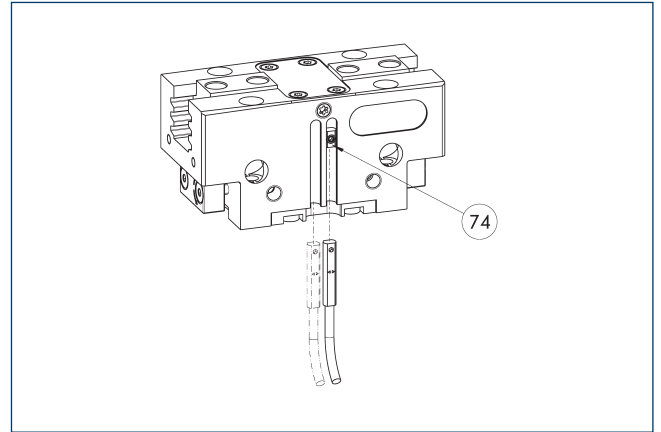

74 Limit stop for sensor

Position monitoring with two programmable positions per sensor. End position monitoring for mounting in the C-slot.

Description	ID	Often combined
Programmable magnetic switch		
MMSK-P 22-S-PNP	0301371	
MMS-P 22-S-M8-PNP	0301370	●
Connection cables		
KA GLN0804-LK-00500-A	0307767	●
KA GLN0804-LK-01000-A	0307768	
KA WLN0804-LK-00500-A	0307765	
KA WLN0804-LK-01000-A	0307766	
Clip for connector/socket		
CLI-M8	0301463	
Sensor distributor		
V2-M8-4P-2XM8-3P	0301380	

- ① One sensor is required per unit for monitoring two positions. Extension cables and sensor distributors are optionally available. Additional product variants of the sensor, and further information and technical data can be found in the catalog chapter sensor systems.

Analog position sensor MMS-A

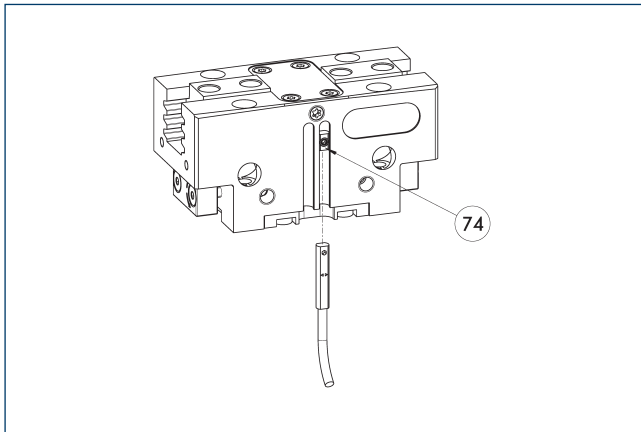

74 Limit stop for sensor

Non-contact measuring, analog multi-position monitoring for any number of positions, easy to assemble in the C-slot. Can be programmed using MT magnetic teaching tool (included in the scope of delivery, ID 0301030) or ST plug teaching tool (optional). End position monitoring for mounting in the C-slot. If the ST plug teaching tools are listed in the chart provided, teaching is only possible with the ST teaching tools.

Description	ID	
Analog position sensor		
MMS 22-A-10V-M08	0315825	
MMS 22-A-10V-M12	0315828	

① One sensor is required for each gripper. No additional mounting kit is required – the gripper is equipped for use of the sensor by default. Further information and technical data can be found in the catalog chapter sensor systems.

Flexible position sensor with MMS-A

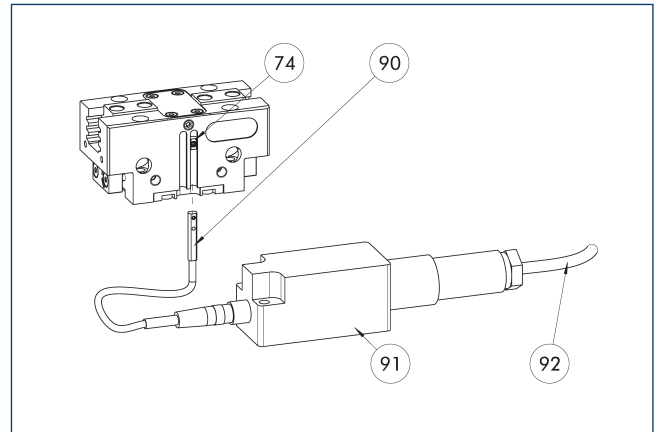

74 Limit stop for sensor

90 MMS 22-A-... sensor

91 FPS-F5 evaluation electronic

92 Connection cables

Flexible position monitoring of up to five positions. Sensor can be taught using MT magnetic teaching tool (included in the scope of delivery, ID 0301030) or ST plug teaching tool (optional). If the ST plug teaching tools are listed in the table provided, teaching is only possible with the ST teaching tools.

Description	ID	
Analog position sensor		
MMS 22-A-05V-M08	0315805	
Evaluation electronics		
FPS-F5	0301805	
Sensor Teaching Tool		
MT-MMS 22-PI	0301030	
Connection cables		
KA BG16-L 12P-1000	0301801	

① When using an FPS system, one MMS 22-A-05V and one evaluation electronics (FPS-F5) are required per each gripper, as well as an attachment kit (AS), if listed. On option, cable extensions (KV) are available – see catalog chapter "Accessories."

PGN-plus-P 160

Universal gripper

Programmable magnetic switch MMS-IO-Link

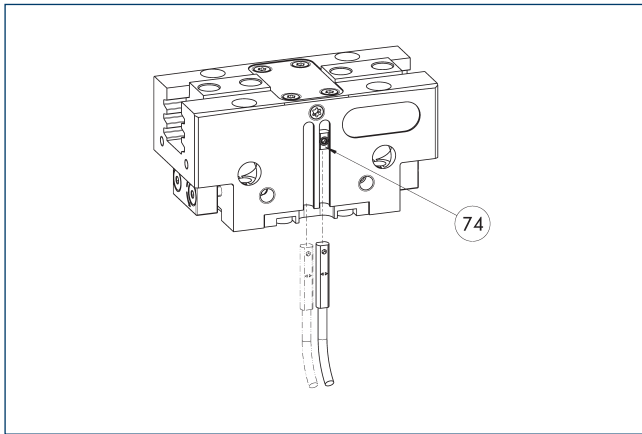

74 Limit stop for sensor

Sensor for multi-position monitoring through detection of the complete gripper stroke. The sensor is mounted directly in the C-slot of the gripper. The sensor is programmed for the gripper via the IO-Link interface, Magnet teaching tool MT (included in scope of delivery; ID 0301030) or the ST plug teaching tool (not included in scope of delivery; ID 0301026). An IO-Link master is required for operation.

Description	ID	
Programmable magnetic switch		
MMS 22-IOL-M08	0315830	
MMS 22-IOL-M12	0315835	

① One sensor is required for each gripper. No additional mounting kit is required – the gripper is equipped for use of the sensor by default. Further information and technical data can be found in the catalog chapter sensor systems.

APS-Z80 analog position sensor

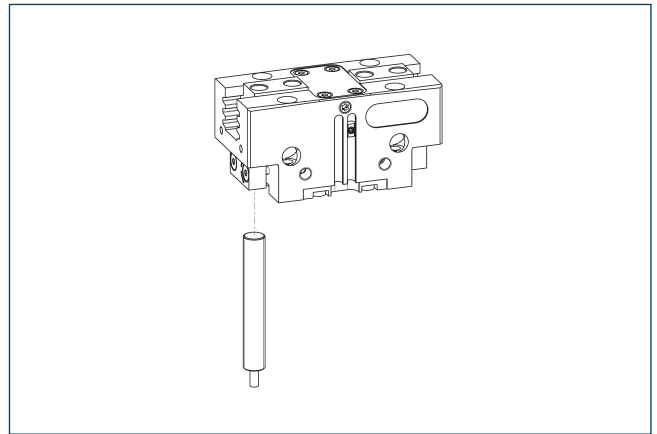

Non-contact measuring, analog multi-position monitoring for any number of positions.

Description	ID	Often combined
Mounting kit for APS-Z80		
AS-APS-Z80-PGN-plus-P 160-1	1374181	
AS-APS-Z80-PGN-plus-P 160-2	1374182	
Analog position sensor		
APS-Z80-K	0302072	
APS-Z80-M8	0302070	●

① When using an APS system, one mounting kit (AS-APS-Z80) and one APS-Z80 sensor is required per gripper. The resolution of the sensor can be lower in the peripheral areas of the gripper. You can find further information on the product in the operating manual.

APS-M1 analog position sensor

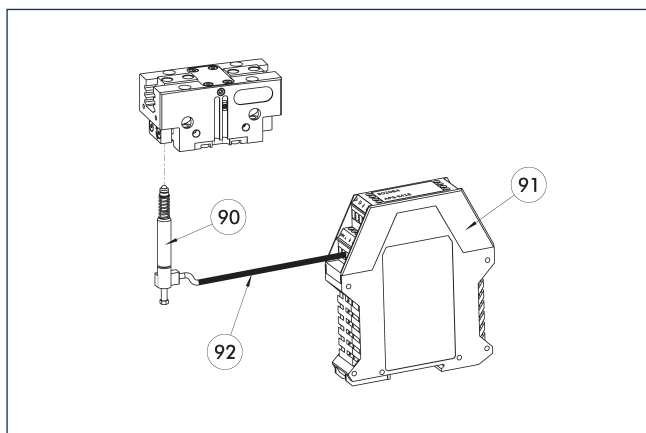

- ⑨⑩ APS-M1S sensor
- ⑨① APS-M1E electronic processor
- ⑨② APS-K extension cable

Analog multi position monitoring for any desired positions

Description	ID	
Mounting kit for APS-M1		
AS-APS-M1-PGN-plus-P 160-1	1374144	
AS-APS-M1-PGN-plus-P 160-2	1374159	
Analog position sensor		
APS-M1S	0302062	
Connection cables		
APS-K0200	0302066	
APS-K0700	0302068	
Evaluation electronics		
APS-M1E	0302064	

- ① When using an APS system, for each gripper an attachment kit (AS-APS-M1), an APS-M1S sensor (incl. 3 m cable) as well as an electronics (APS-M1e) are required. An extension cable (APS-K) can be connected between the sensor and the electronics as an option. The max. cable length between the sensor and the electronics is 10 m, between the electronics and their control unit (PLC) it is max. 1 m.

PGN-plus-P 200

Universal gripper



Gripping force O.D. gripping

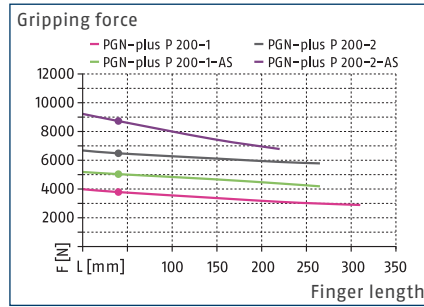

Gripping force I.D. gripping

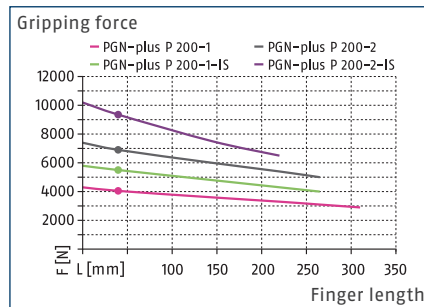

Dimensions and maximum loads

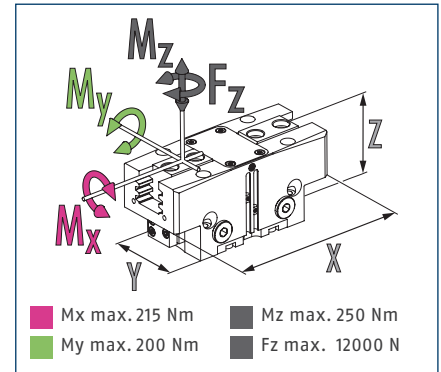

① The indicated moments and forces are static values, apply for each base jaw and may appear simultaneously. Loads may additionally occur to the moment produced by the gripping force itself.

Technical data

Description		PGN-plus-P 200-1	PGN-plus-P 200-2	PGN-plus-P 200-1-AS	PGN-plus-P 200-2-AS	PGN-plus-P 200-1-IS	PGN-plus-P 200-2-IS
ID		0318616	0318617	0318618	0318619	0318620	0318621
Stroke per jaw	[mm]	25	14	25	14	25	14
Closing/opening force	[N]	3800/4050	6500/6900	5050/-	8750/-	-/5500	-/9350
Min. spring force	[N]			1250	2250	1450	2450
Weight	[kg]	5.2	5.4	6.8	7	6.6	6.8
Recommended workpiece weight	[kg]	19	32.5	19	32.5	19	32.5
Fluid consumption double stroke	[cm ³]	510	510	810	810	890	890
Min./nom./max. operating pressure	[bar]	2.5/6/8	2.5/6/8	4/6/6.5	4/6/6.5	4/6/6.5	4/6/6.5
Min./max. air purge pressure	[bar]	0.5/1	0.5/1	0.5/1	0.5/1	0.5/1	0.5/1
Closing/opening time	[s]	0.28/0.28	0.28/0.28	0.24/0.55	0.24/0.55	0.55/0.24	0.55/0.24
Closing/opening time with spring	[s]			0.40	0.40	0.40	0.40
Max. permissible finger length	[mm]	310	265	265	220	265	220
Max. permissible weight per finger	[kg]	6.5	6.5	6.5	6.5	6.5	6.5
IP protection class		40	40	40	40	40	40
Min./max. ambient temperature	[°C]	5/90	5/90	5/90	5/90	5/90	5/90
Repeat accuracy	[mm]	0.02	0.02	0.02	0.02	0.02	0.02
Dimensions X x Y x Z	[mm]	234 x 100 x 91	234 x 100 x 91	234 x 100 x 141	234 x 100 x 141	234 x 100 x 141	234 x 100 x 141
Options and their characteristics							
Dustproof version		1317683	1317691	1317695	1317696	1317701	1317703
IP protection class		64	64	64	64	64	64
Weight	[kg]	6	6	7.6	7.6	7.4	7.4
Corrosion-protected version		1317675	1317676	1317678	1317679	1317680	1317681
High-temperature version		1317663	1317665	1317666	1317667	1317670	1317674
Min./max. ambient temperature	[°C]	5/130	5/130	5/130	5/130	5/130	5/130
Precision version		1317705	1317706	1317708	1317710		

① It may take a few 100 gripping cycles until the full gripping force (as indicated in the data table) will be available.

PGN-plus-P 200

Universal gripper

Maximum permitted finger projection

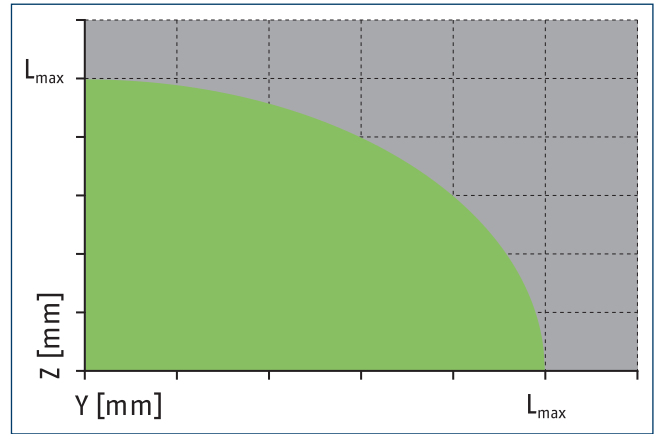
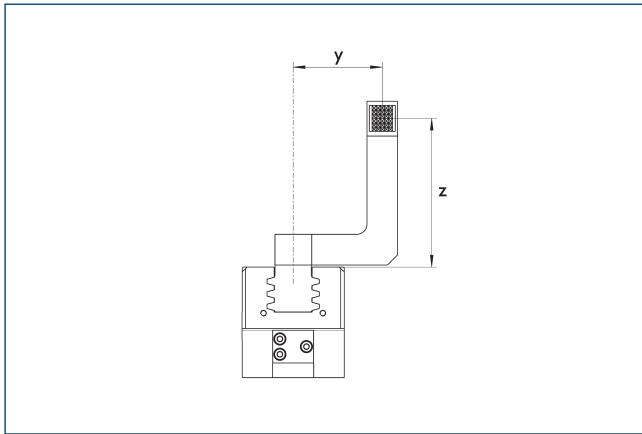

■ Permitted range ■ Inadmissible range

L_{max} is equivalent to the maximum permitted finger length, see the technical data table.

Hose-free direct connection M5

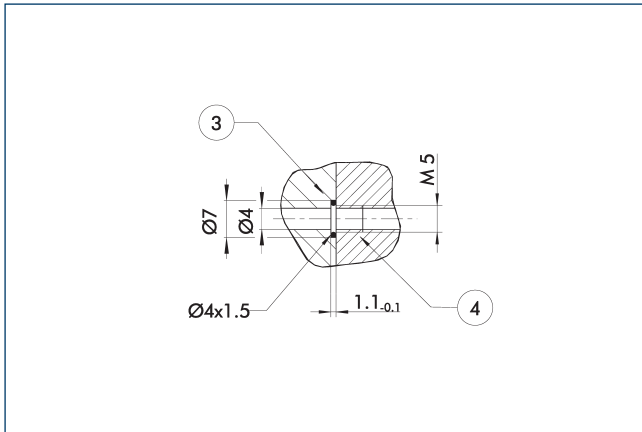

③ Adapter

④ Grippers

The direct connection is used for supplying compressed air without hoses. Instead, the pressure medium is fed through bore-holes in the mounting plate.

Gripping force maintenance version AS/IS

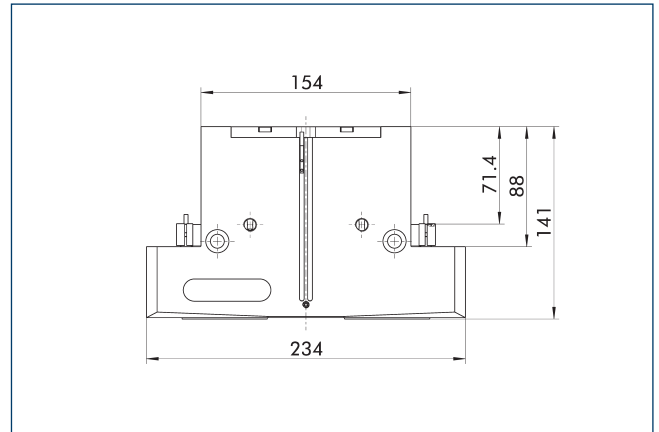

The mechanical gripping force maintenance device ensures that a minimum clamping force will be applied even if there is a drop in pressure. In the AS/S variant this acts as a closing force, in the IS variant as an opening force. Besides this, gripping force maintenance can be used to increase gripping force or for single actuated gripping.

Dustproof version

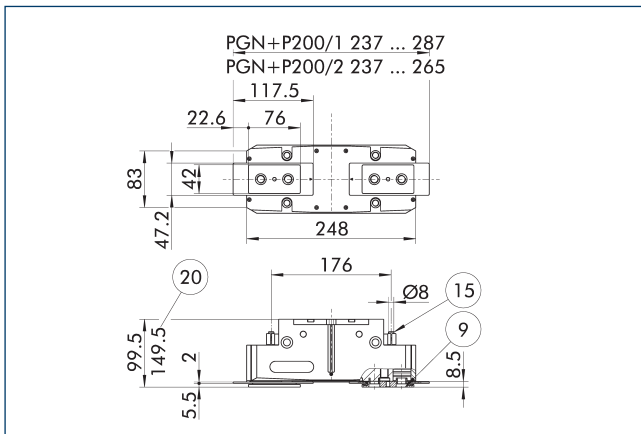

- ⑨ For mounting screw connection diagram, see basic version
- ⑮ Sealing bolt
- ⑳ For version AS/IS

The "dustproof" option increases the degree of protection against penetrating substances. The assembly diagram shifts by the height of the intermediate jaw. The finger length is still measured from the upper edge of the gripper housing.

Description	ID
Dust cover	
SAD PGN-plus-P 200	1347583

- ① The "dustproof" option can either be ordered as a pre-mounted gripper version or can be retrofitted to the gripper using the "SAD PGN-plus-P" retrofit kit.

Precision version

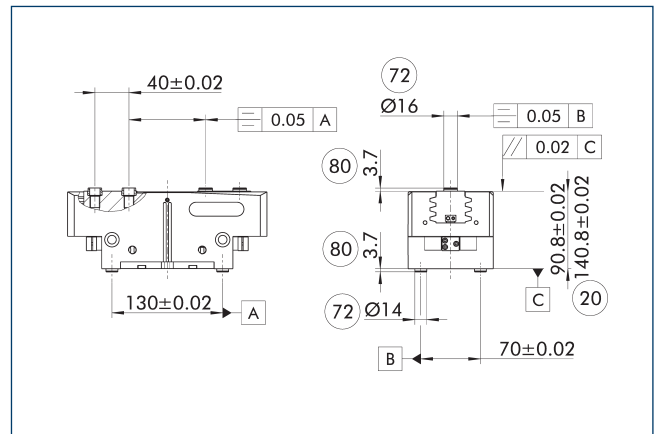

- ⑳ For version AS/IS
- ㉓ Fit for centering sleeves
- ㉔ Depth of the centering sleeve hole in the counter part

The indicated tolerances just refer to the variants of precision versions shown in the chart of technical specifications. All other variants of precision versions are available on request.

PGN-plus-P 200

Universal gripper

SDV-P pressure maintenance valve

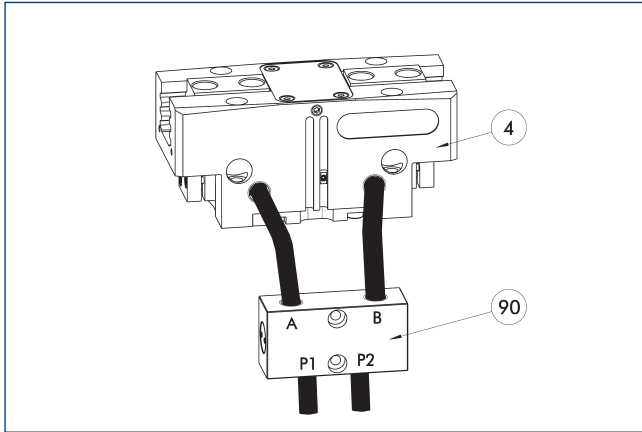

④ Grippers

⑨⑩ SDV-P pressure maintenance valve

The SDV-P pressure maintenance valve ensures in emergency STOP situations that the pressure in the piston chamber of pneumatic gripper, swivel, linear, and quick-change modules is temporarily maintained.

Description	ID	Recommended hose diameter [mm]
Pressure maintenance valve		
SDV-P 07	0403131	8
Pressure maintenance valve with air bleed screw		
SDV-P 07-E	0300121	8
SDV-P 10-E	0300109	10

① In order to achieve the specified closing and opening time for each gripper variant, the recommended hose diameter must be used. The direct allocation of the respective variant of the gripper for the respective SDV-P can be found at schunk.com.

Pneumatic positioning device PPD

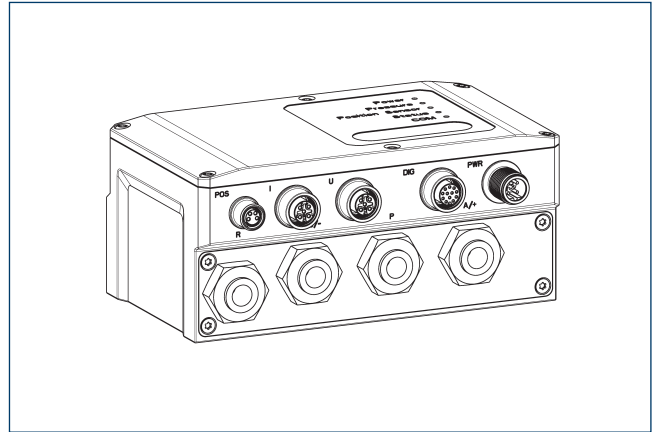

The PPD allows flexibility in all applications with pneumatic grippers through free positioning, gripping force and speed adjustment.

Description	ID	
Pneumatic positioning device		
PPD 40-IOL	1540701	
Adapter		
A GGN0804-1204-A	1540691	
IO-Link connection cable		
KA GGN1205-1212-IOL-00100-A	1540697	
Voltage supply connection cable - cable track compatible		
KA GLN12B05-LK-01000-A	1540660	
Cable extension		
KV GGN0804-IO-00150-A	1540662	
KV GGN0804-IO-00300-A	1540663	
Assembly set		
Assembly set PPD	1540705	

① In addition to the PPD, a position sensor (SCHUNK IO-Link sensor or analog sensor (4...20 mA)) is required.

BSWS jaw quick-change jaw systems

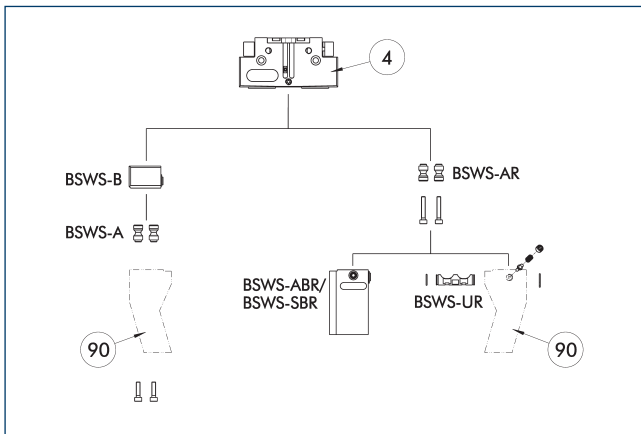

④ Grippers

⑨0 Customized gripper fingers

There are various jaw quick-change systems available for the gripper. For detailed information, please refer to the corresponding product.

Description	ID	Scope of delivery
Quick-change jaw system base		
BSWS-B 200	0303033	1
Jaw quick-change system adapter pin		
BSWS-A 200	0303032	2

① If the operating pressure is higher than 6 bar, suitability for use beyond the application limits must be checked. Only systems that are listed in the table, can be used.

Fields of application

Series	Size	Variant	Suitability
PGN-plus-P	200	-1 (6 bar)	■■■■
PGN-plus-P	200	-1-AS/1-IS (6 bar)	■■□□
PGN-plus-P	200	-2 (6 bar)	■■□□
PGN-plus-P	200	-2-AS/2-IS (6 bar)	■■□□
Legend			
■■■■	Can be combined without restrictions		
■■□□	Use with restrictions (see loading limits)		
□□□□	cannot be combined		

The load limits for describing the application limits can be found in the catalog chapter of the corresponding accessories.

Jaw quick-change system BSWS-M

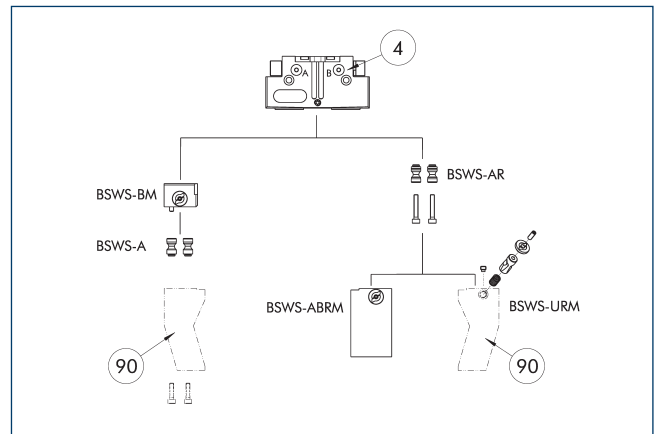

④ Grippers

⑨0 Customized gripper fingers

There are various jaw quick-change systems available for the gripper. For detailed information, please refer to the corresponding product.

Description	ID	Scope of delivery
Quick-change jaw system base		
BSWS-BM 200	1419306	1
Jaw quick-change system adapter pin		
BSWS-A 200	0303032	2

① If the operating pressure is higher than 6 bar, suitability for use beyond the application limits must be checked. Only systems that are listed in the table, can be used.

Fields of application

Series	Size	Variant	Suitability
PGN-plus-P	200	-1 (6 bar)	■■■■
PGN-plus-P	200	-1-AS/1-IS (6 bar)	■■□□
PGN-plus-P	200	-2 (6 bar)	■■□□
PGN-plus-P	200	-2-AS/2-IS (6 bar)	■■□□
Legend			
■■■■	Can be combined without restrictions		
■■□□	Use with restrictions (see loading limits)		
□□□□	cannot be combined		

The load limits for describing the application limits can be found in the catalog chapter of the corresponding accessories.

PGN-plus-P 200

Universal gripper

ZBA-L-plus 200 intermediate jaws

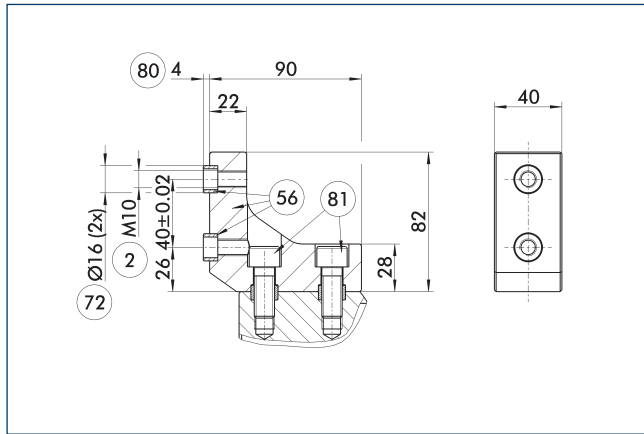

- ② Finger connection
- ⑤⑥ Included in the scope of delivery
- ⑦② Fit for centering sleeves
- ⑧① Depth of the centering sleeve hole in the counter part
- ⑧① Not included in the scope of delivery

Optionally intermediate jaws can be used, enabling direct connection and alignment of top jaws and various standard accessories in Z-direction.

Description	ID	Material	Finger interface	Scope of delivery
Intermediate jaw				
ZBA-L-plus 200	0311772	Aluminum	PGN-plus 200	1

UZB 200 universal intermediate jaw

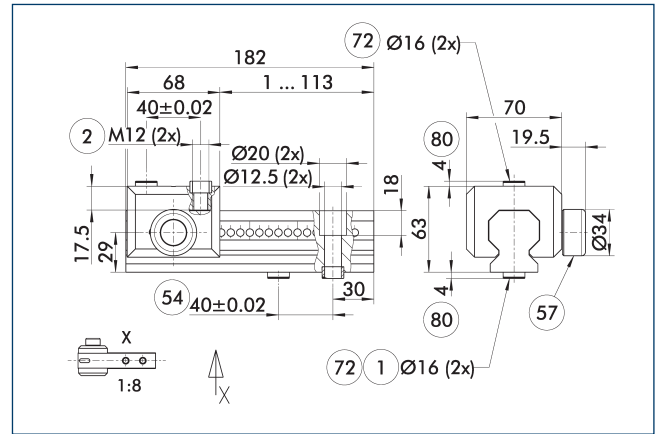

- ① Gripper connection
- ② Finger connection
- ⑤④ Optional right or left connection
- ⑤⑦ Locking
- ⑦② Fit for centering sleeves
- ⑧① Depth of the centering sleeve hole in the counter part

The drawing shows the UZB universal intermediate jaw. The fully removable UZB-S slide (can also be ordered separately) allows for a quick jaw change.

Description	ID	Grid dimension
Universal intermediate jaw		
UZB 200	0300047	7
Finger blank		
ABR-PGZN-plus 200	0300015	
SBR-PGZN-plus 200	0300025	
Slide for universal intermediate jaw		
UZB-S 200	5518275	7

ⓘ If the operating pressure is higher than 6 bar, suitability for use beyond the application limits must be checked.

Fields of application

Series	Size	Variant	Suitability
PGN-plus-P	200	-1 (6 bar)	■■■■
PGN-plus-P	200	-1-AS/1-IS (6 bar)	■■□□
PGN-plus-P	200	-2 (6 bar)	■■□□
PGN-plus-P	200	-2-AS/2-IS (6 bar)	□□□□

Legend	
■■■■	Can be combined without restrictions
■■□□	Use with restrictions (see loading limits)
□□□□	cannot be combined

The load limits for describing the application limits can be found in the catalog chapter of the corresponding accessories.

Finger blanks ABR/SBR-PGZN-plus 200

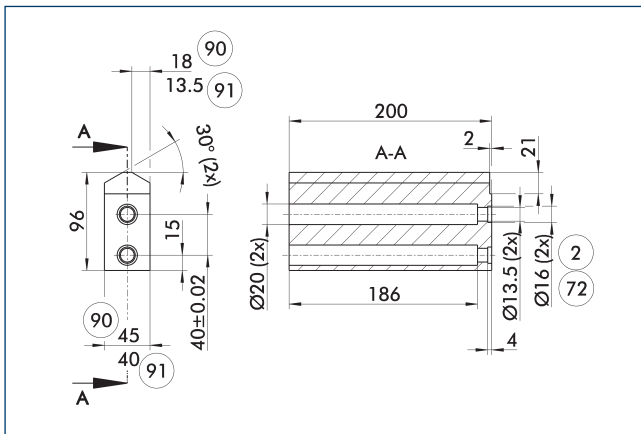

- ② Finger connection
- ⑦② Fit for centering sleeves
- ⑨① ABR-PGZN-plus
- ⑨① SBR-PGZN-plus

The drawing shows the finger blank which can be reworked by the customer.

Description	ID	Material	Scope of delivery
Finger blank			
ABR-PGZN-plus 200	0300015	Aluminum (3.4365)	1
SBR-PGZN-plus 200	0300025	Steel (1.7131)	1

Tolerance compensation unit TCU

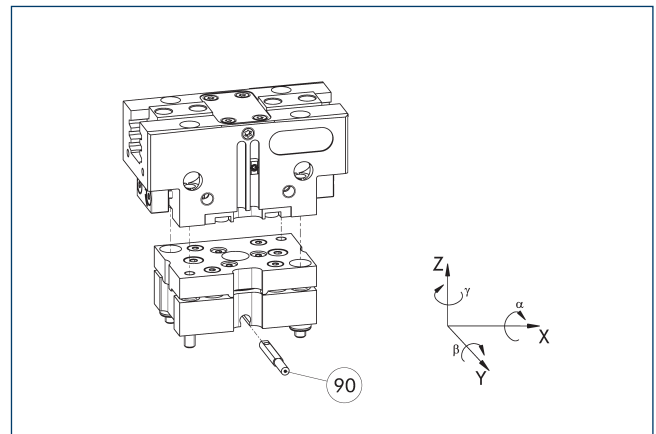

- ⑨① Monitoring of locking

Grippers can be directly mounted without an adapter plate. Tolerance compensation unit and gripper have an identical screw connection diagram. Therefore the tolerance compensation units can be assembled later. Please consider the additional assembly height of the tolerance compensation unit. For details please refer to our catalog robot accessories.

Description	ID	Locking	Deflection	Often combined
Compensation unit				
TCU-P-200-3-MV	0324864	yes	$\pm 1^\circ / \pm 2^\circ / \pm 1,5^\circ$	●
TCU-P-200-3-OV	0324865	no	$\pm 1^\circ / \pm 2^\circ / \pm 1,5^\circ$	

PGN-plus-P 200

Universal gripper

Inductive proximity switches

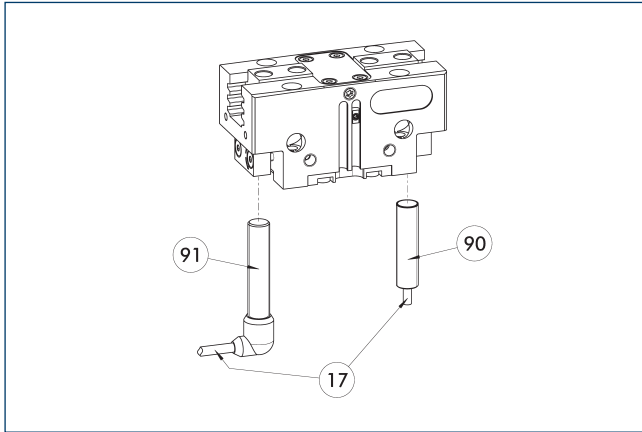

- 17 Cable outlet
- 90 Sensor IN ...
- 91 Sensor IN..-SA

Directly mounted end position monitoring.

Description	ID	Often combined
Inductive proximity switches		
IN 80-S-M12	0301578	
IN 80-S-M8	0301478	●
INK 80-S	0301550	
Inductive proximity switch with lateral cable outlet		
IN 80-S-M12-SA	0301587	
IN 80-S-M8-SA	0301483	●
INK 80-S-SA	0301566	
Connection cables		
KA BG08-L 3P-0300-PNP	0301622	●
KA BG08-L 3P-0500-PNP	0301623	
KA BG12-L 3P-0500-PNP	30016369	
KA BW08-L 3P-0300-PNP	0301594	
KA BW08-L 3P-0500-PNP	0301502	
KA BW12-L 3P-0300-PNP	0301503	
KA BW12-L 3P-0500-PNP	0301507	
Clip for connector/socket		
CLI-M12	0301464	
CLI-M8	0301463	
Cable extension		
KV BG12-SG12 3P-0030-PNP	0301999	
KV BG12-SG12 3P-0060-PNP	0301998	
KV BW08-SG08 3P-0030-PNP	0301495	
KV BW08-SG08 3P-0100-PNP	0301496	
KV BW08-SG08 3P-0200-PNP	0301497	●
KV BW12-SG12 3P-0030-PNP	0301595	
KV BW12-SG12 3P-0100-PNP	0301596	
KV BW12-SG12 3P-0200-PNP	0301597	
Sensor distributor		
V2-M12	0301776	●
V2-M8	0301775	●
V4-M8	0301746	
V8-M8	0301751	

- ① Two sensors are required per unit for monitoring two positions. On option, extension cables and sensor distributors are available. Additional product variants of the sensor, and further information and technical data can be found in the catalog chapter sensor system.

Flexible position sensor

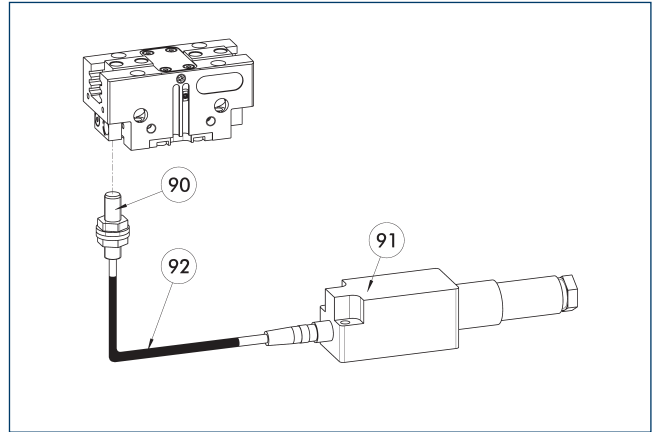

- 90 FPS-S sensor
- 91 FPS-F5 evaluation electronic
- 92 Cable extension

Flexible position monitoring of up to five positions.

Description	ID	
Attachment kit for FPS		
AS-FPS-PGN-plus-P 200-1	1388827	
AS-FPS-PGN-plus-P 200-2	1388829	
Sensor		
FPS-S M8	0301704	
Evaluation electronics		
FPS-F5	0301805	
Cable extension		
KV BG08-SG08 3P-0050	0301598	
KV BG08-SG08 3P-0100	0301599	

- ① When using an FPS system, an FPS sensor (FPS-S) as well as an electronic processor (FPS-F5 / F5 T) are required for each gripper as well as a mounting kit (AS), if listed. Cable extensions (KV) are optionally available – see catalog chapter “Accessories.”

Electronic magnetic switch MMS

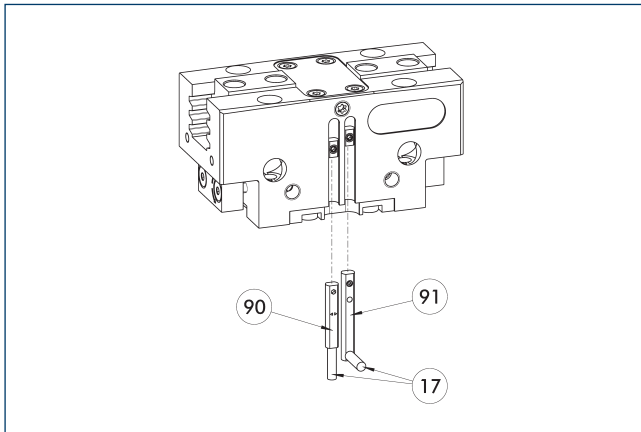

- ①⑦ Cable outlet
- ①⑨ Sensor MMS 22...-SA
- ①⑩ Sensor MMS 22..

End position monitoring for mounting in the C-slot.

Description	ID	Often combined
Electronic magnetic switch		
MMS 22-S-M8-PNP	0301032	●
MMSK 22-S-PNP	0301034	
Electronic magnetic switches with lateral cable outlet		
MMS 22-S-M8-PNP-SA	0301042	●
MMSK 22-S-PNP-SA	0301044	
Connection cables		
KA BG08-L 3P-0300-PNP	0301622	●
KA BG08-L 3P-0500-PNP	0301623	
KA BW08-L 3P-0300-PNP	0301594	
KA BW08-L 3P-0500-PNP	0301502	
Clip for connector/socket		
CLI-M8	0301463	
Cable extension		
KV BW08-SG08 3P-0030-PNP	0301495	
KV BW08-SG08 3P-0100-PNP	0301496	
KV BW08-SG08 3P-0200-PNP	0301497	●
Sensor distributor		
V2-M8	0301775	●
V4-M8	0301746	
V8-M8	0301751	

- ① Two sensors are required per unit for monitoring two positions. On option, extension cables and sensor distributors are available. Additional product variants of the sensor, and further information and technical data can be found in the catalog chapter sensor system.

Programmable magnetic switch MMS 22-PI1

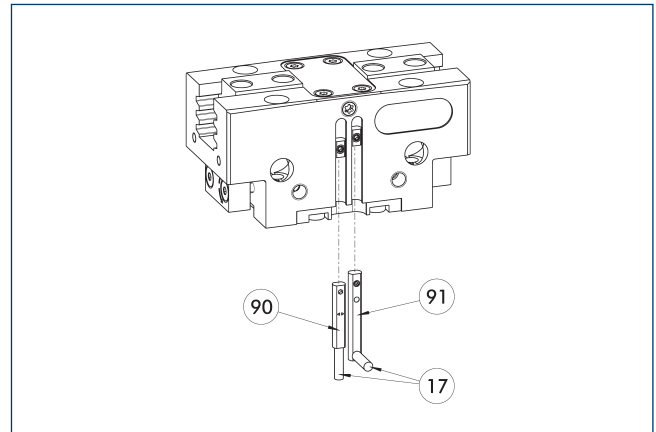

- ①⑦ Cable outlet
- ①⑨ Sensor MMS 22 ..-PI1...-SA
- ①⑩ Sensor MMS 22 PI1...

Position monitoring with one programmable position per sensor and integrated electronic system in the sensor. Can be programmed using MT magnetic teaching tool (included in the scope of delivery, ID 0301030) or ST plug teaching tool (optional). End position monitoring for mounting in the C-slot. If the ST plug teaching tools are listed in the table provided, teaching is only possible with the ST teaching tools.

Description	ID	Often combined
Programmable magnetic switch		
MMS 22-PI1-S-M8-PNP	0301160	●
MMSK 22-PI1-S-PNP	0301162	
Programmable magnetic switch with lateral cable outlet		
MMS 22-PI1-S-M8-PNP-SA	0301166	●
MMSK 22-PI1-S-PNP-SA	0301168	
Programmable magnetic switch with stainless steel housing		
MMS 22-PI1-S-M8-PNP-HD	0301110	●
MMSK 22-PI1-S-PNP-HD	0301112	

- ① Two sensors are required per unit for monitoring two positions. On option, extension cables and sensor distributors are available. Additional product variants of the sensor, and further information and technical data can be found in the catalog chapter sensor system.

PGN-plus-P 200

Universal gripper

Programmable magnetic switch MMS 22-PI2

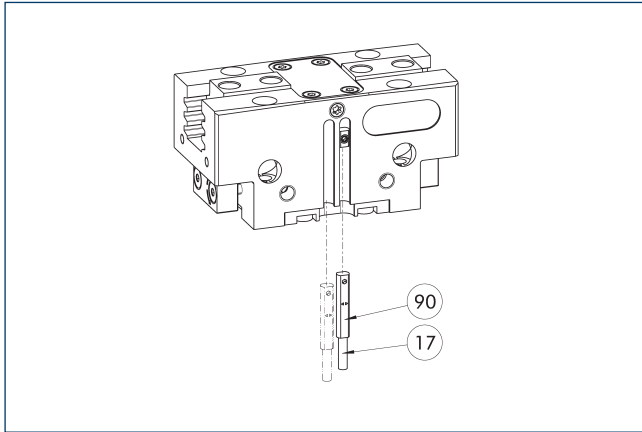

17 Cable outlet

90 MMS 22...-PI2-... sensor

Position monitoring with two programmable positions per sensor and electronics integrated in the sensor. Can be programmed using MT magnetic teaching tool (included in the scope of delivery, ID 0301030) or ST plug teaching tool (optional). End position monitoring for mounting in the C-slot. If the ST plug teaching tools are listed in the table provided, teaching is only possible with the ST teaching tools.

Description	ID	Often combined
Programmable magnetic switch		
MMS 22-PI2-S-M8-PNP	0301180	●
MMSK 22-PI2-S-PNP	0301182	
Programmable magnetic switch with lateral cable outlet		
MMS 22-PI2-S-M8-PNP-SA	0301186	●
MMSK 22-PI2-S-PNP-SA	0301188	
Programmable magnetic switch with stainless steel housing		
MMS 22-PI2-S-M8-PNP-HD	0301130	●
MMSK 22-PI2-S-PNP-HD	0301132	

- ① One sensor is required per unit for monitoring two positions. Extension cables and sensor distributors are optionally available. Additional product variants of the sensor, and further information and technical data can be found in the catalog chapter sensor systems.

MMS-P programmable magnetic switch

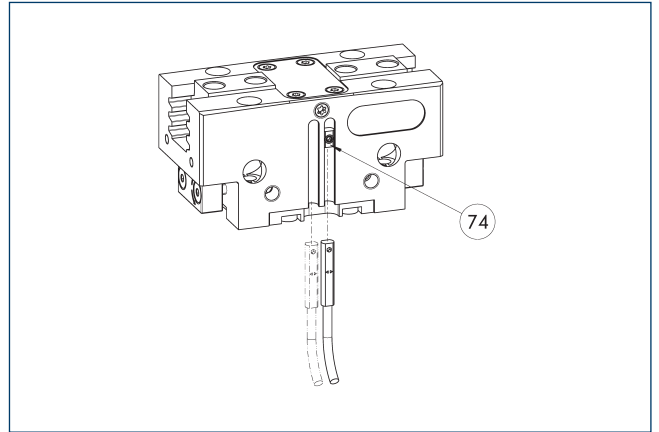

74 Limit stop for sensor

Position monitoring with two programmable positions per sensor. End position monitoring for mounting in the C-slot.

Description	ID	Often combined
Programmable magnetic switch		
MMSK-P 22-S-PNP	0301371	
MMS-P 22-S-M8-PNP	0301370	●
Connection cables		
KA GLN0804-LK-00500-A	0307767	●
KA GLN0804-LK-01000-A	0307768	
KA WLN0804-LK-00500-A	0307765	
KA WLN0804-LK-01000-A	0307766	
Clip for connector/socket		
CLI-M8	0301463	
Sensor distributor		
V2-M8-4P-2XM8-3P	0301380	

- ① One sensor is required per unit for monitoring two positions. Extension cables and sensor distributors are optionally available. Additional product variants of the sensor, and further information and technical data can be found in the catalog chapter sensor systems.

Analog position sensor MMS-A

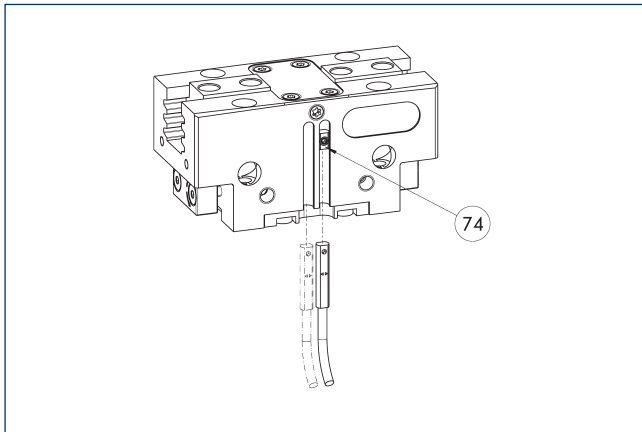

74 Limit stop for sensor

Non-contact measuring, analog multi-position monitoring for any number of positions, easy to assemble in the C-slot. Can be programmed using MT magnetic teaching tool (included in the scope of delivery, ID 0301030) or ST plug teaching tool (optional). End position monitoring for mounting in the C-slot. If the ST plug teaching tools are listed in the chart provided, teaching is only possible with the ST teaching tools.

Description	ID	
Analog position sensor		
MMS 22-A-10V-M08	0315825	
MMS 22-A-10V-M12	0315828	

- ① One sensor is required per unit. The output voltage of the sensor differs according to the unit and is typically between 0.3 and 10 V. The resolution of the sensor can be smaller in the peripheral areas of the gripper. For further information on the product, see operating manual.

Flexible position sensor with MMS-A

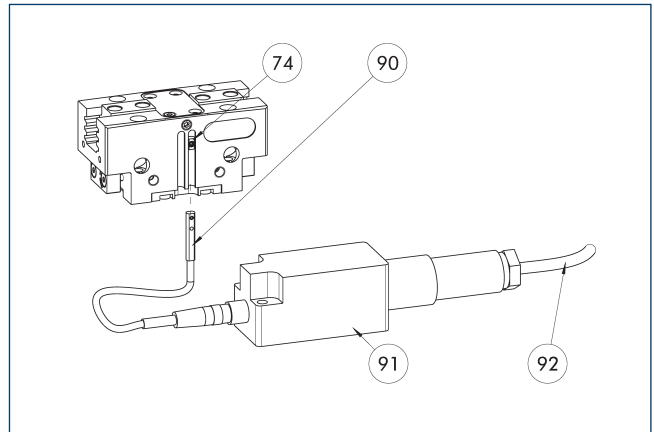

74 Limit stop for sensor

90 MMS 22-A-... sensor

91 FPS-F5 evaluation electronic

92 Connection cables

Flexible position monitoring of up to five positions. Sensor can be taught using MT magnetic teaching tool (included in the scope of delivery, ID 0301030) or ST plug teaching tool (optional). If the ST plug teaching tools are listed in the table provided, teaching is only possible with the ST teaching tools.

Description	ID	
Analog position sensor		
MMS 22-A-05V-M08	0315805	
Evaluation electronics		
FPS-F5	0301805	
Sensor Teaching Tool		
MT-MMS 22-PI	0301030	
Connection cables		
KA BG16-L 12P-1000	0301801	

- ① When using an FPS system, one MMS 22-A-05V and one evaluation electronics (FPS-F5) are required per each gripper, as well as an attachment kit (AS), if listed. On option, cable extensions (KV) are available – see catalog chapter “Accessories.” The resolution of the sensor can be lower in the peripheral areas of the gripper. Further information on the product can be found in the operating manual.

PGN-plus-P 200

Universal gripper

Programmable magnetic switch MMS-IO-Link

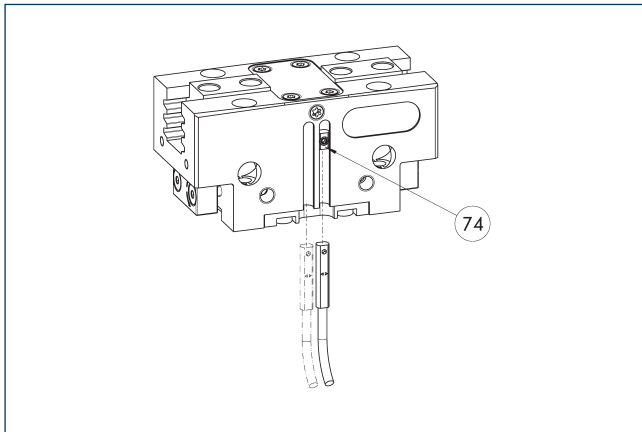

74 Limit stop for sensor

Sensor for multi-position monitoring through detection of the complete gripper stroke. The sensor is mounted directly in the C-slot of the gripper. The sensor is programmed for the gripper via the IO-Link interface, Magnet teaching tool MT (included in scope of delivery; ID 0301030) or the ST plug teaching tool (not included in scope of delivery; ID 0301026). An IO-Link master is required for operation.

Description	ID	
Programmable magnetic switch		
MMS 22-IOL-M08	0315830	
MMS 22-IOL-M12	0315835	

① One sensor is required for each gripper. No additional mounting kit is required – the gripper is equipped for use of the sensor by default. Further information and technical data can be found in the catalog chapter sensor systems.

APS-Z80 analog position sensor

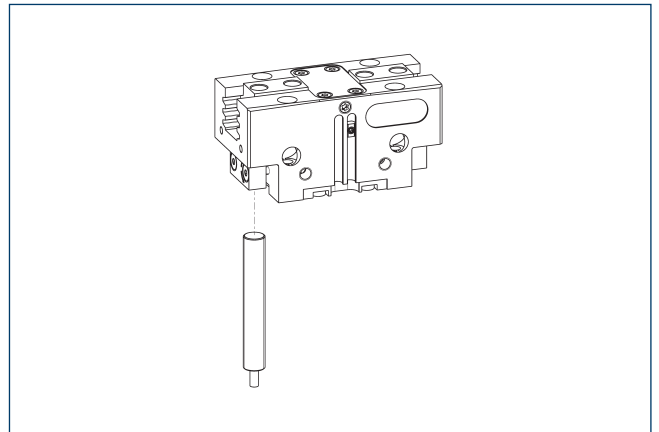

Non-contact measuring, analog multi-position monitoring for any number of positions.

Description	ID	Often combined
Mounting kit for APS-Z80		
AS-APS-Z80-PGN-plus-P 200-1	1374183	
AS-APS-Z80-PGN-plus-P 200-2	1374184	
Analog position sensor		
APS-Z80-K	0302072	
APS-Z80-M8	0302070	●

① When using an APS system, one mounting kit (AS-APS-Z80) and one APS-Z80 sensor is required per gripper. The resolution of the sensor can be lower in the peripheral areas of the gripper. You can find further information on the product in the operating manual.

APS-M1 analog position sensor

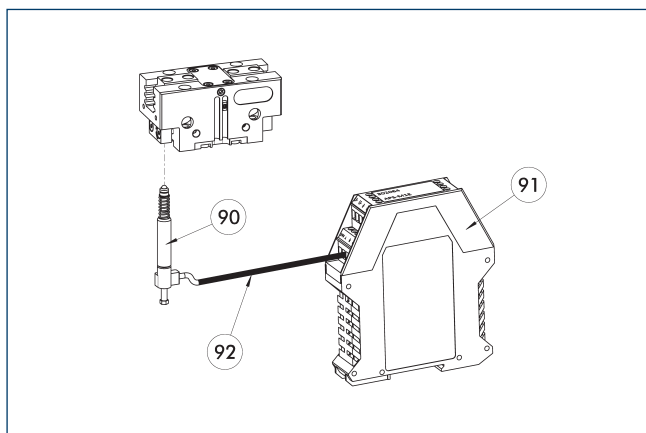

- ⑨⑩ APS-M1S sensor
- ⑨① APS-M1E electronic processor
- ⑨② APS-K extension cable

Analog multi position monitoring for any desired positions

Description	ID	
Mounting kit for APS-M1		
AS-APS-M1-PGN-plus-P 200-1	1374166	
AS-APS-M1-PGN-plus-P 200-2	1374175	
Analog position sensor		
APS-M1S	0302062	
Connection cables		
APS-K0200	0302066	
APS-K0700	0302068	
Evaluation electronics		
APS-M1E	0302064	

- ① When using an APS system, for each gripper an attachment kit (AS-APS-M1), an APS-M1S sensor (incl. 3 m cable) as well as an electronics (APS-M1e) are required. An extension cable (APS-K) can be connected between the sensor and the electronics as an option. The max. cable length between the sensor and the electronics is 10 m, between the electronics and their control unit (PLC) it is max. 1 m.

PGN-plus-P 240

Universal gripper



Gripping force O.D. gripping

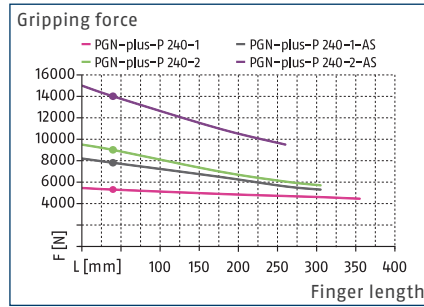

Gripping force I.D. gripping

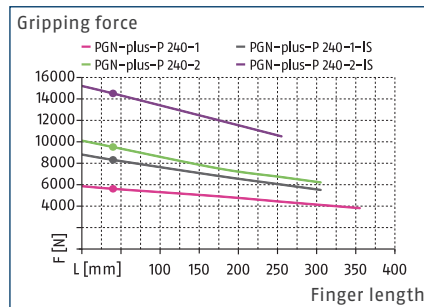

Dimensions and maximum loads

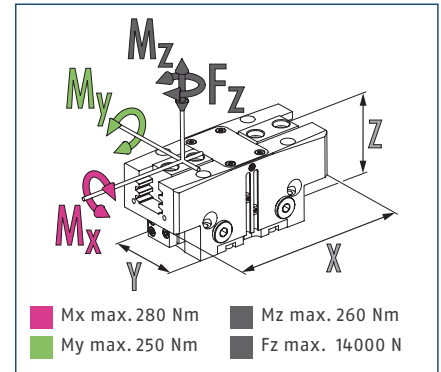

① The indicated moments and forces are static values, apply for each base jaw and may appear simultaneously. Loads may additionally occur to the moment produced by the gripping force itself.

Technical data

Description		PGN-plus-P 240-1	PGN-plus-P 240-2	PGN-plus-P 240-1-AS	PGN-plus-P 240-2-AS	PGN-plus-P 240-1-IS	PGN-plus-P 240-2-IS
ID		0318640	0318641	0318642	0318643	0318644	0318645
Stroke per jaw	[mm]	30	17	30	17	30	17
Closing/opening force	[N]	5300/5600	9000/9500	7800/-	14000/-	-/8300	-/14500
Min. spring force	[N]			2500	5000	2700	5000
Weight	[kg]	8.6	8.9	11.6	11.9	11.3	11.6
Recommended workpiece weight	[kg]	26.5	45	26.5	45	26.5	45
Fluid consumption double stroke	[cm ³]	900	900	1300	1300	1400	1400
Min./nom./max. operating pressure	[bar]	2.5/6/8	2.5/6/8	4/6/6.5	4/6/6.5	4/6/6.5	4/6/6.5
Min./max. air purge pressure	[bar]	0.5/1	0.5/1	0.5/1	0.5/1	0.5/1	0.5/1
Closing/opening time	[s]	0.5/0.5	0.5/0.5	0.45/0.9	0.45/0.9	0.9/0.45	0.9/0.45
Closing/opening time with spring	[s]			0.60	0.60	0.60	0.60
Max. permissible finger length	[mm]	355	305	305	260	305	260
Max. permissible weight per finger	[kg]	9.5	9.5	9.5	9.5	9.5	9.5
IP protection class		40	40	40	40	40	40
Min./max. ambient temperature	[°C]	5/90	5/90	5/90	5/90	5/90	5/90
Repeat accuracy	[mm]	0.04	0.04	0.04	0.04	0.04	0.04
Dimensions X x Y x Z	[mm]	270 x 115 x 107	270 x 115 x 107	270 x 115 x 163.5	270 x 115 x 163.5	270 x 115 x 163.5	270 x 115 x 163.5
Options and their characteristics							
Dustproof version		1317742	1317744	1317745	1317749	1317752	1317755
IP protection class		64	64	64	64	64	64
Weight	[kg]	9.4	9.6	12.5	12.7	12.2	12.4
Corrosion-protected version		1317732	1317735	1317737	1317738	1317739	1317740
High-temperature version		1317715	1317717	1317722	1317724	1317725	1317729
Min./max. ambient temperature	[°C]	5/130	5/130	5/130	5/130	5/130	5/130
Precision version		1317758	1317759	1317760	1317761		

① It may take a few 100 gripping cycles until the full gripping force (as indicated in the data table) will be available.

Main view

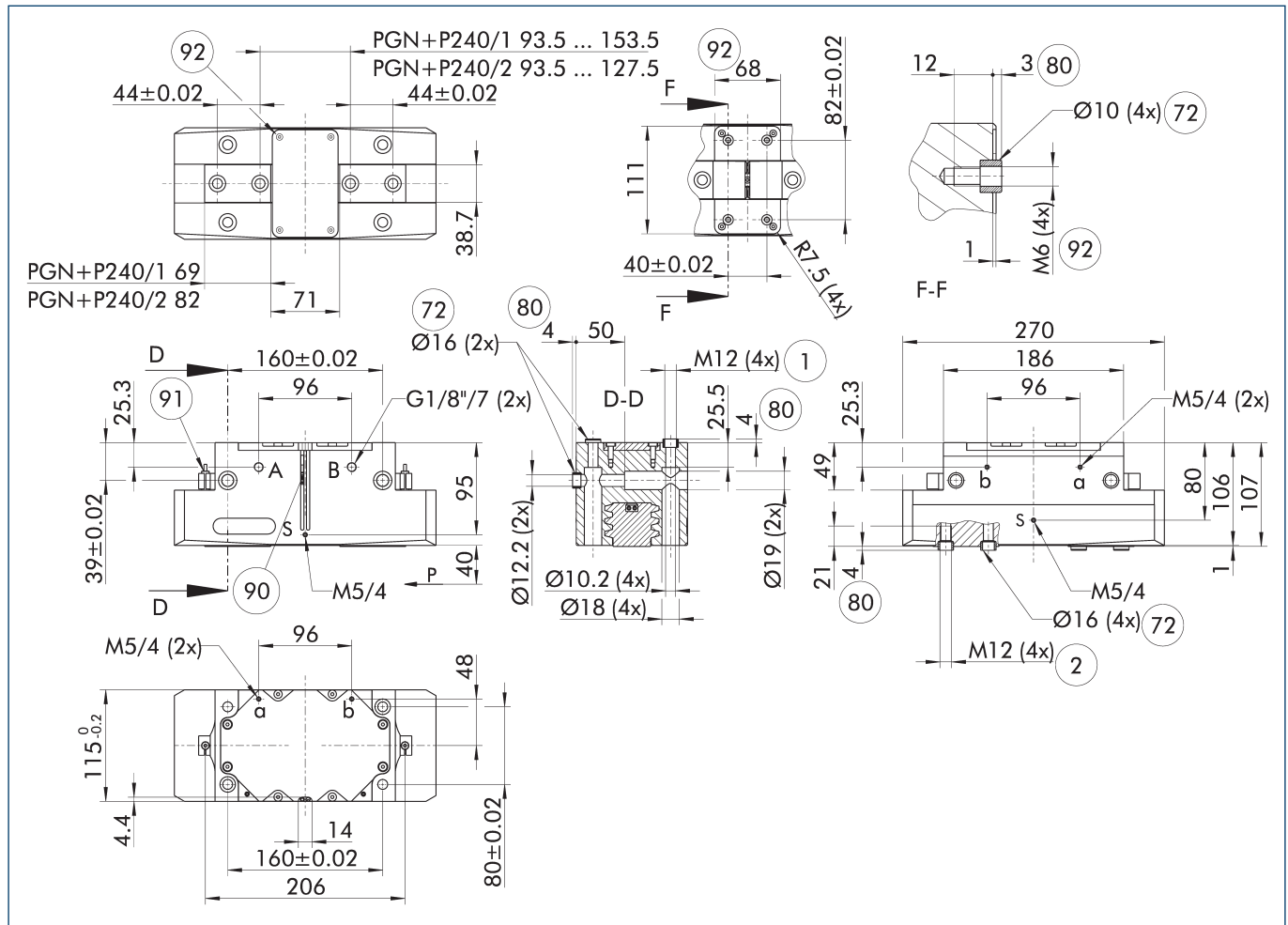

The drawing shows the gripper in the basic version with closed jaws, without dimensional consideration of the options described below.

① As an alternative/in addition to spring-assisted mechanical gripping force maintenance, the SDV-P pressure maintenance valve can be used for I.D. and O.D. gripping (see "Accessories" section of catalog).

- A, a Main / direct connection, gripper opening
- B, b Main / direct connection, gripper closing
- S Air purge connection
- ① Gripper connection
- ② Finger connection
- ⑦ Fit for centering sleeves

- ⑧ Depth of the centering sleeve hole in the counter part
- ⑨ Sensor MMS 22..
- ⑩ Sensor IN ...
- ⑪ Screw connection with centering for customized mounting (these centering sleeves are not included in the scope of delivery)

PGN-plus-P 240

Universal gripper

Maximum permitted finger projection

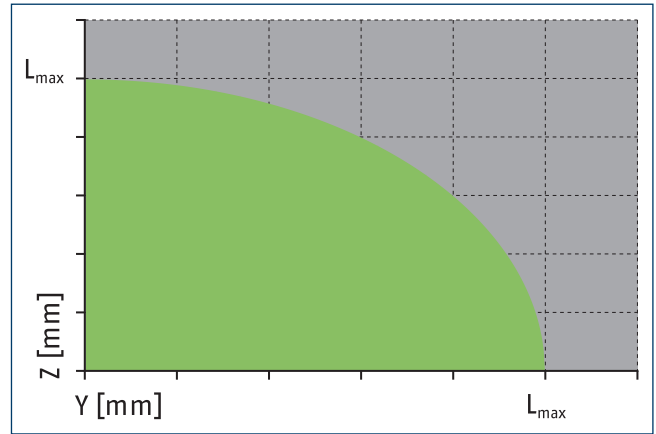
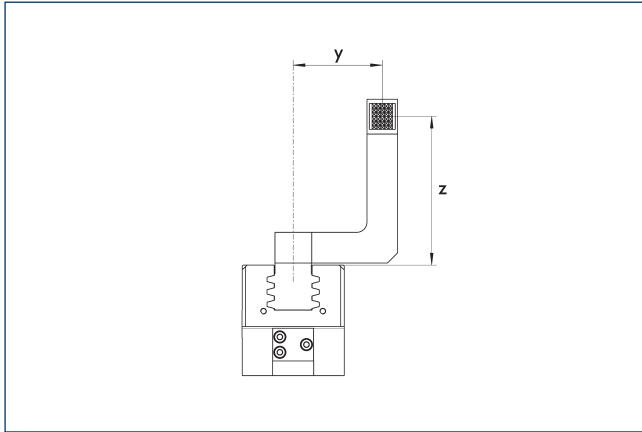

■ Permitted range

■ Inadmissible range

L_{max} is equivalent to the maximum permitted finger length, see the technical data table.

Hose-free direct connection M5

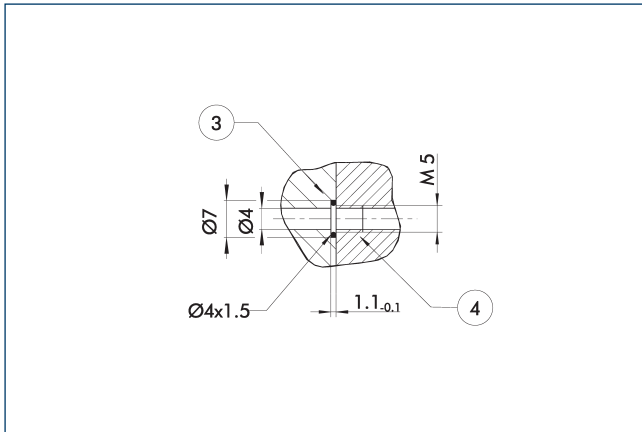

③ Adapter

④ Grippers

The direct connection is used for supplying compressed air without hoses. Instead, the pressure medium is fed through bore-holes in the mounting plate.

Gripping force maintenance version AS/IS

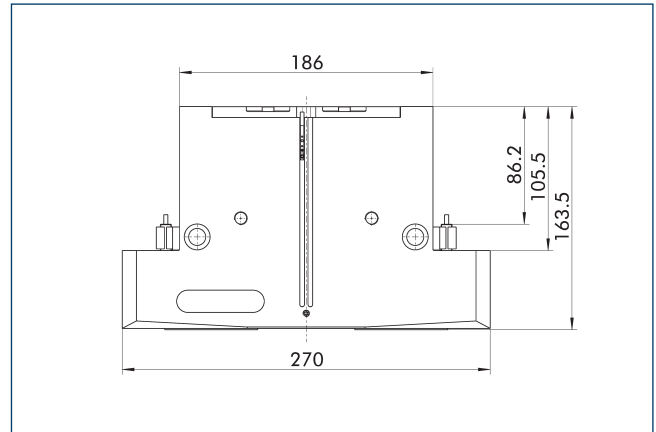

The mechanical gripping force maintenance device ensures that a minimum clamping force will be applied even if there is a drop in pressure. In the AS/S variant this acts as a closing force, in the IS variant as an opening force. Besides this, gripping force maintenance can be used to increase gripping force or for single actuated gripping.

Dustproof version

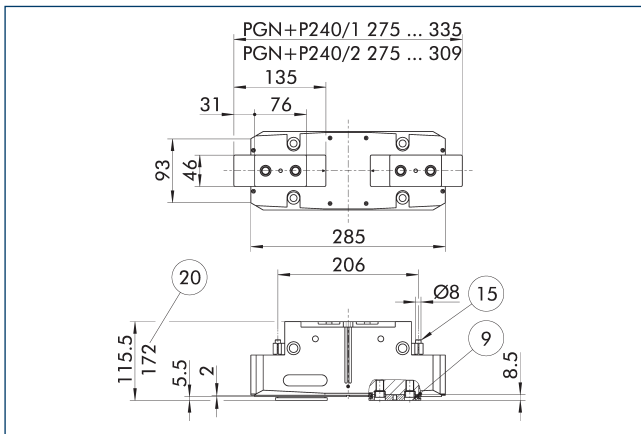

- ⑨ For mounting screw connection diagram, see basic version
- ⑮ Sealing bolt
- ⑳ For version AS/IS

The "dustproof" option increases the degree of protection against penetrating substances. The assembly diagram shifts by the height of the intermediate jaw. The finger length is still measured from the upper edge of the gripper housing.

Description	ID
Dust cover	
SAD PGN-plus-P 240	1347587

- ① The "dustproof" option can either be ordered as a pre-mounted gripper version or can be retrofitted to the gripper using the "SAD PGN-plus-P" retrofit kit.

Precision version

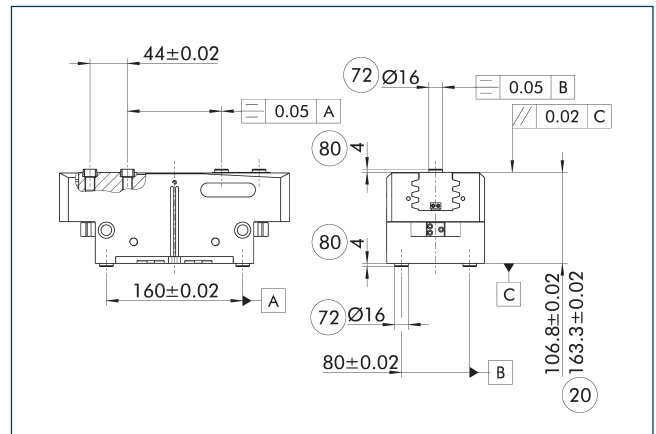

- ⑳ For version AS/IS
- ㉓ Fit for centering sleeves
- ⑧① Depth of the centering sleeve hole in the counter part

The indicated tolerances just refer to the variants of precision versions shown in the chart of technical specifications. All other variants of precision versions are available on request.

PGN-plus-P 240

Universal gripper

SDV-P pressure maintenance valve

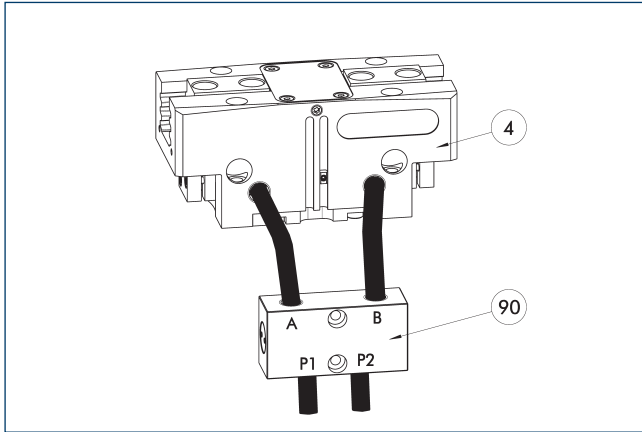

④ Grippers

⑨⑩ SDV-P pressure maintenance valve

The SDV-P pressure maintenance valve ensures in emergency STOP situations that the pressure in the piston chamber of pneumatic gripper, swivel, linear, and quick-change modules is temporarily maintained.

Description	ID	Recommended hose diameter [mm]
Pressure maintenance valve		
SDV-P 07	0403131	8
Pressure maintenance valve with air bleed screw		
SDV-P 07-E	0300121	8
SDV-P 10-E	0300109	10

① In order to achieve the specified closing and opening time for each gripper variant, the recommended hose diameter must be used. The direct allocation of the respective variant of the gripper for the respective SDV-P can be found at schunk.com.

BSWS jaw quick-change jaw systems

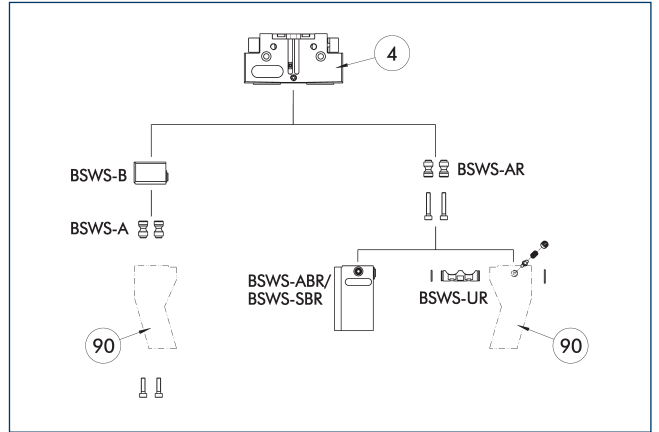

④ Grippers

⑨⑩ Customized gripper fingers

There are various jaw quick-change systems available for the gripper. For detailed information, please refer to the corresponding product.

Description	ID	Scope of delivery
Quick-change jaw system base		
BSWS-B 240	0303035	1
Jaw quick-change system adapter pin		
BSWS-A 240	0303034	2

① If the operating pressure is higher than 6 bar, suitability for use beyond the application limits must be checked. Only systems that are listed in the table, can be used.

Fields of application

Series	Size	Variant	Suitability
PGN-plus-P	240	-1 (6 bar)	■■■■■
PGN-plus-P	240	-1-AS/1-IS (6 bar)	■■■■■
PGN-plus-P	240	-2 (6 bar)	■■□□
PGN-plus-P	240	-2-AS/2-IS (6 bar)	■■□□

Legend	
■■■■■	Can be combined without restrictions
■■□□	Use with restrictions (see loading limits)
□□□□	cannot be combined

The load limits for describing the application limits can be found in the catalog chapter of the corresponding accessories.

ZBA-L-plus 240 intermediate jaws

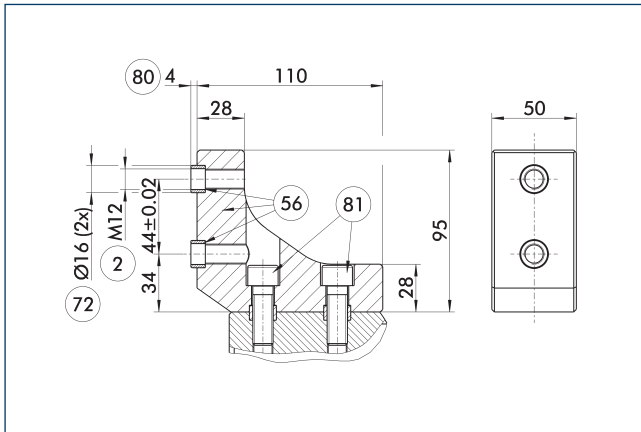

- ② Finger connection
- ⑤⑥ Included in the scope of delivery
- ⑦② Fit for centering sleeves
- ⑧⑩ Depth of the centering sleeve hole in the counter part
- ⑧① Not included in the scope of delivery

The optional ZBA-L-plus intermediate jaws allow the screw connection diagram of the top jaws to be rotated by 90°. This makes it easier to design and produce top jaws (particularly for long versions) because no deep through-bores are required.

Description	ID	Material	Finger interface	Scope of delivery
Intermediate jaw				
ZBA-L-plus 240	0311782	Aluminum	PGN-plus 240	1

Finger blanks ABR/SBR-PGZN-plus 240

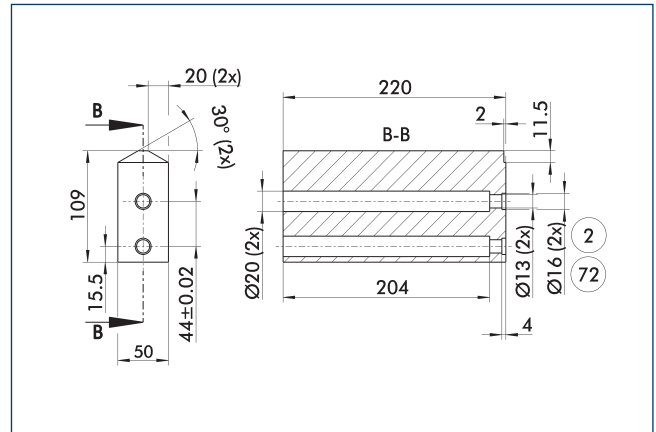

- ② Finger connection
- ⑦② Fit for centering sleeves

The drawing shows the finger blank which can be reworked by the customer.

Description	ID	Material	Scope of delivery
Finger blank			
ABR-PGZN-plus 240	0300017	Aluminum (3.4365)	1
SBR-PGZN-plus 240	0300027	Steel (1.7131)	1

Tolerance compensation unit TCU

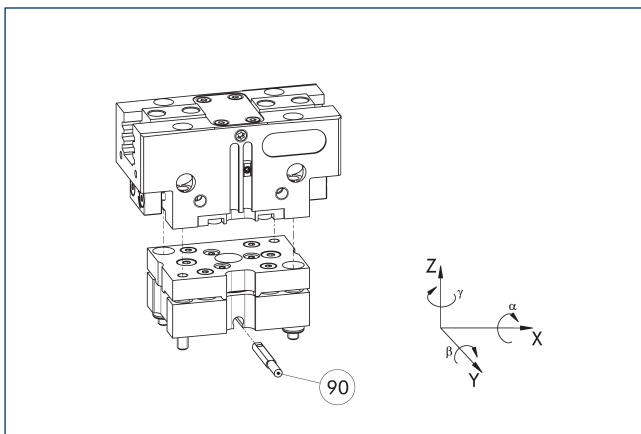

- ⑨⑩ Monitoring of locking

Grippers can be directly mounted without an adapter plate. Tolerance compensation unit and gripper have an identical screw connection diagram. Therefore the tolerance compensation units can be assembled later. Please consider the additional assembly height of the tolerance compensation unit. For details please refer to our catalog robot accessories.

Description	ID	Locking	Deflection	Often combined
Compensation unit				
TCU-P-240-3-MV	0324730	yes	±1°/±1,5°/±1°	●
TCU-P-240-3-0V	0324731	no	±1°/±1,5°/±1°	

PGN-plus-P 240

Universal gripper

Inductive proximity switches

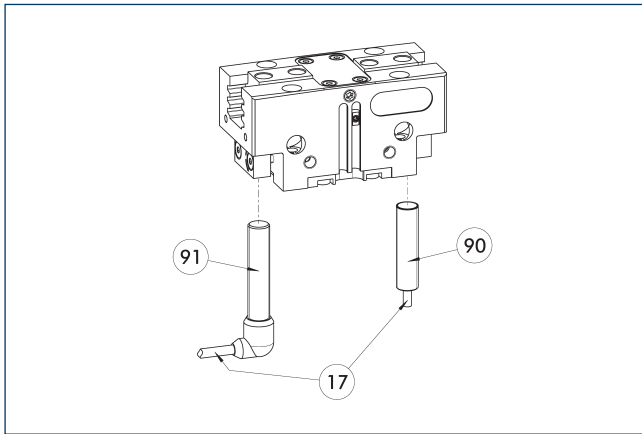

17 Cable outlet

91 Sensor IN..-SA

90 Sensor IN ...

Directly mounted end position monitoring.

Description	ID	Often combined
Inductive proximity switches		
IN 80-S-M12	0301578	
IN 80-S-M8	0301478	●
INK 80-S	0301550	
Inductive proximity switch with lateral cable outlet		
IN 80-S-M12-SA	0301587	
IN 80-S-M8-SA	0301483	●
INK 80-S-SA	0301566	
Connection cables		
KA BG08-L 3P-0300-PNP	0301622	●
KA BG08-L 3P-0500-PNP	0301623	
KA BG12-L 3P-0500-PNP	30016369	
KA BW08-L 3P-0300-PNP	0301594	
KA BW08-L 3P-0500-PNP	0301502	
KA BW12-L 3P-0300-PNP	0301503	
KA BW12-L 3P-0500-PNP	0301507	
Clip for connector/socket		
CLI-M12	0301464	
CLI-M8	0301463	
Cable extension		
KV BG12-SG12 3P-0030-PNP	0301999	
KV BG12-SG12 3P-0060-PNP	0301998	
KV BW08-SG08 3P-0030-PNP	0301495	
KV BW08-SG08 3P-0100-PNP	0301496	
KV BW08-SG08 3P-0200-PNP	0301497	●
KV BW12-SG12 3P-0030-PNP	0301595	
KV BW12-SG12 3P-0100-PNP	0301596	
KV BW12-SG12 3P-0200-PNP	0301597	
Sensor distributor		
V2-M12	0301776	●
V2-M8	0301775	●
V4-M8	0301746	
V8-M8	0301751	

① Two sensors are required per unit for monitoring two positions. On option, extension cables and sensor distributors are available. Additional product variants of the sensor, and further information and technical data can be found in the catalog chapter sensor system.

Flexible position sensor

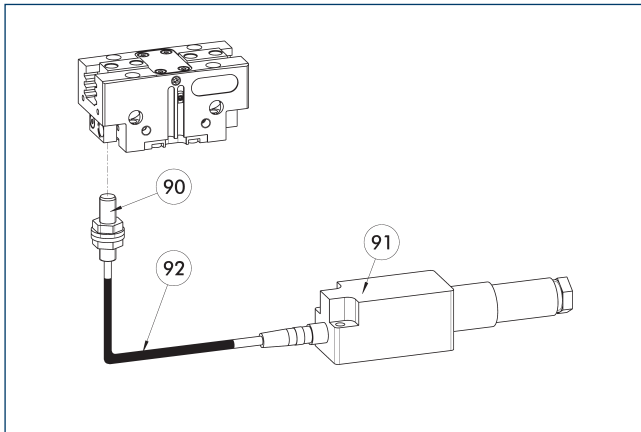

- ⑨⑩ FPS-S sensor
- ⑨① FPS-F5 evaluation electronic
- ⑨② Cable extension

Flexible position monitoring of up to five positions.

Description	ID	
Attachment kit for FPS		
AS-FPS-PGN-plus-P 240-1	1388834	
AS-FPS-PGN-plus-P 240-2	1388840	
Sensor		
FPS-S M8	0301704	
Evaluation electronics		
FPS-F5	0301805	
Cable extension		
KV BG08-SG08 3P-0050	0301598	
KV BG08-SG08 3P-0100	0301599	

- ① When using an FPS system, an FPS sensor (FPS-S) as well as an electronic processor (FPS-F5 / F5 T) are required for each gripper as well as a mounting kit (AS), if listed. Cable extensions (KV) are optionally available – see catalog chapter "Accessories."

Electronic magnetic switch MMS

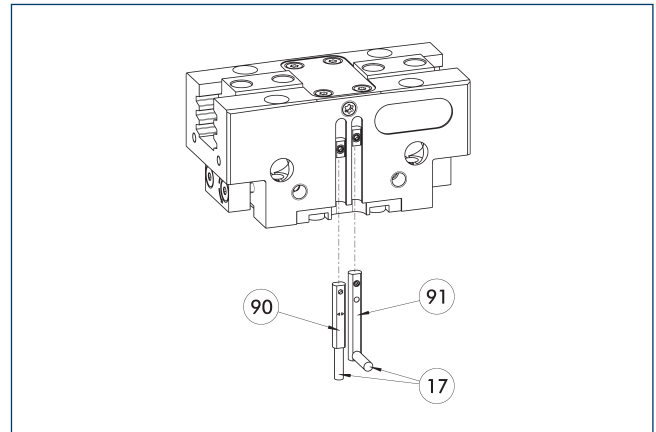

- ①⑦ Cable outlet
- ①⑨ Sensor MMS 22..
- ①⑩ Sensor MMS 22...
- ①① Sensor MMS 22...-SA

End position monitoring for mounting in the C-slot.

Description	ID	Often combined
Electronic magnetic switch		
MMS 22-S-M8-PNP	0301032	●
MMSK 22-S-PNP	0301034	
Electronic magnetic switches with lateral cable outlet		
MMS 22-S-M8-PNP-SA	0301042	●
MMSK 22-S-PNP-SA	0301044	
Connection cables		
KA BG08-L 3P-0300-PNP	0301622	●
KA BG08-L 3P-0500-PNP	0301623	
KA BW08-L 3P-0300-PNP	0301594	
KA BW08-L 3P-0500-PNP	0301502	
Clip for connector/socket		
CLI-M8	0301463	
Cable extension		
KV BW08-SG08 3P-0030-PNP	0301495	
KV BW08-SG08 3P-0100-PNP	0301496	
KV BW08-SG08 3P-0200-PNP	0301497	●
Sensor distributor		
V2-M8	0301775	●
V4-M8	0301746	
V8-M8	0301751	

- ① Two sensors are required per unit for monitoring two positions. On option, extension cables and sensor distributors are available. Additional product variants of the sensor, and further information and technical data can be found in the catalog chapter sensor system.

PGN-plus-P 240

Universal gripper

Programmable magnetic switch MMS 22-PI1

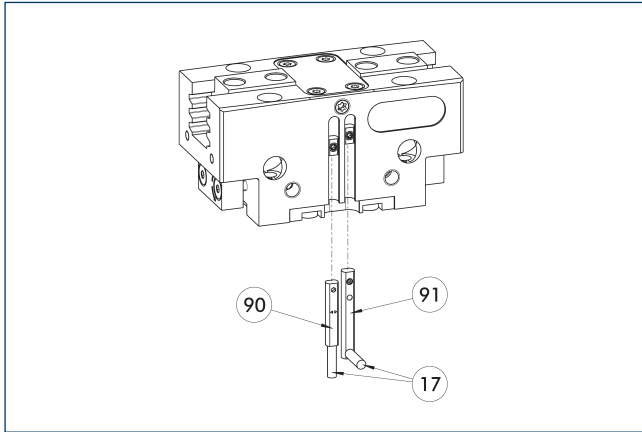

- ①⑦ Cable outlet
- ①⑨ Sensor MMS 22 ..-PI1-...-SA
- ①⑩ Sensor MMS 22 PI1-...

Position monitoring with one programmable position per sensor and integrated electronic system in the sensor. Can be programmed using MT magnetic teaching tool (included in the scope of delivery, ID 0301030) or ST plug teaching tool (optional). End position monitoring for mounting in the C-slot. If the ST plug teaching tools are listed in the table provided, teaching is only possible with the ST teaching tools.

Description	ID	Often combined
Programmable magnetic switch		
MMS 22-PI1-S-M8-PNP	0301160	●
MMSK 22-PI1-S-PNP	0301162	
Programmable magnetic switch with lateral cable outlet		
MMS 22-PI1-S-M8-PNP-SA	0301166	●
MMSK 22-PI1-S-PNP-SA	0301168	
Programmable magnetic switch with stainless steel housing		
MMS 22-PI1-S-M8-PNP-HD	0301110	●
MMSK 22-PI1-S-PNP-HD	0301112	

- ① Two sensors are required per unit for monitoring two positions. On option, extension cables and sensor distributors are available. Additional product variants of the sensor, and further information and technical data can be found in the catalog chapter sensor system.

APS-Z80 analog position sensor

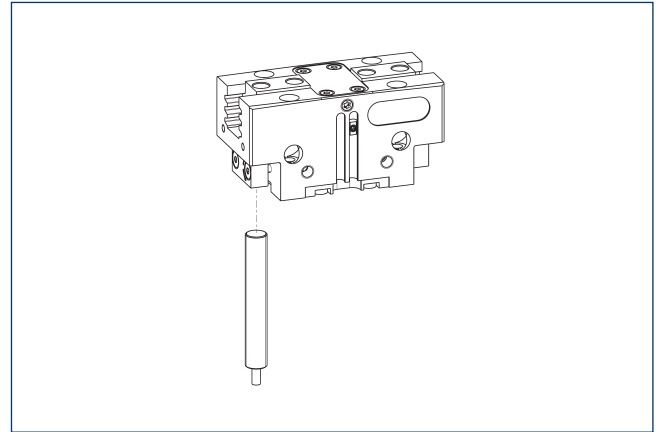

Non-contact measuring, analog multi-position monitoring for any number of positions.

Description	ID	Often combined
Mounting kit for APS-Z80		
AS-APS-Z80-PGN-plus-P 240-1	1374185	
AS-APS-Z80-PGN-plus-P 240-2	1374186	
Analog position sensor		
APS-Z80-K	0302072	
APS-Z80-M8	0302070	●

- ① When using an APS system, one mounting kit (AS-APS-Z80) and one APS-Z80 sensor is required per gripper. The resolution of the sensor can be lower in the peripheral areas of the gripper. You can find further information on the product in the operating manual.

APS-M1 analog position sensor

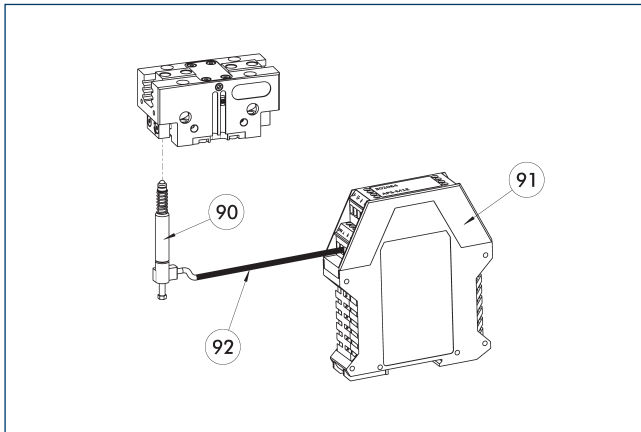

- ⑨⑩ APS-M1S sensor
- ⑨① APS-M1E electronic processor
- ⑨② APS-K extension cable

Analog multi position monitoring for any desired positions

Description	ID	
Mounting kit for APS-M1		
AS-APS-M1-PGN-plus-P 240-1	1374178	
AS-APS-M1-PGN-plus-P 240-2	1374180	
Analog position sensor		
APS-M1S	0302062	
Connection cables		
APS-K0200	0302066	
APS-K0700	0302068	
Evaluation electronics		
APS-M1E	0302064	

- ① When using an APS system, for each gripper an attachment kit (AS-APS-M1), an APS-M1S sensor (incl. 3 m cable) as well as an electronics (APS-M1e) are required. An extension cable (APS-K) can be connected between the sensor and the electronics as an option. The max. cable length between the sensor and the electronics is 10 m, between the electronics and their control unit (PLC) it is max. 1 m.

PGN-plus-P 300

Universal gripper



Gripping force O.D. gripping

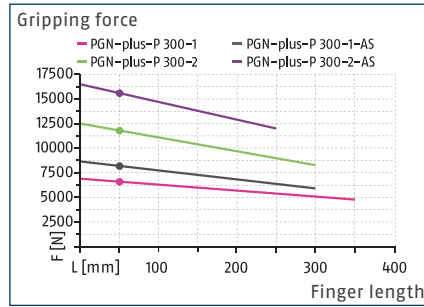

Gripping force I.D. gripping

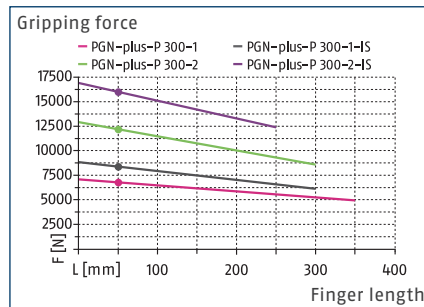

Dimensions and maximum loads

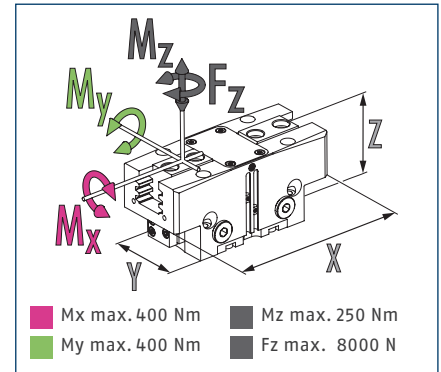

① The indicated moments and forces are static values, apply for each base jaw and may appear simultaneously. Loads may additionally occur to the moment produced by the gripping force itself.

Technical data

Description		PGN-plus-P 300-1	PGN-plus-P 300-2	PGN-plus-P 300-1-AS	PGN-plus-P 300-2-AS	PGN-plus-P 300-1-IS	PGN-plus-P 300-2-IS
ID		1377846	1377878	1377881	1377887	1377888	1377889
Stroke per jaw	[mm]	35	20	35	20	35	20
Closing/opening force	[N]	6600/6800	11800/12200	8200/-	15600/-	-/8400	-/16000
Min. spring force	[N]			1600	3800	1600	3800
Weight	[kg]	13.7	13.7	17.2	17.2	17.2	17.2
Recommended workpiece weight	[kg]	33	59	33	59	33	59
Fluid consumption double stroke	[cm ³]	1040	1040	1295	1295	1560	1560
Min./nom./max. operating pressure	[bar]	2.5/6/8	2.5/6/8	4/6/6.5	4/6/6.5	4/6/6.5	4/6/6.5
Min./max. air purge pressure	[bar]	0.5/1	0.5/1	0.5/1	0.5/1	0.5/1	0.5/1
Closing/opening time	[s]	0.5/0.5	0.5/0.5	0.4/0.7	0.4/0.7	0.7/0.4	0.7/0.4
Closing/opening time with spring	[s]			0.60	0.60	0.60	0.60
Max. permissible finger length	[mm]	350	300	300	250	300	250
Max. permissible weight per finger	[kg]	11.5	11.5	11.5	11.5	11.5	11.5
IP protection class		40	40	40	40	40	40
Min./max. ambient temperature	[°C]	5/90	5/90	5/90	5/90	5/90	5/90
Repeat accuracy	[mm]	0.05	0.05	0.05	0.05	0.05	0.05
Dimensions X x Y x Z	[mm]	320 x 140 x 122	320 x 140 x 122	320 x 140 x 172	320 x 140 x 172	320 x 140 x 172	320 x 140 x 172
Options and their characteristics							
Dustproof version		1377936	1377942	1377947	1377950	1377951	1377958
IP protection class		64	64	64	64	64	64
Weight	[kg]	15.2	15.2	18.7	18.7	18.7	18.7
Corrosion-protected version		1377922	1377923	1377927	1377928	1377930	1377933
High-temperature version		1377892	1377896	1377903	1377912	1377919	1377920
Min./max. ambient temperature	[°C]	5/130	5/130	5/130	5/130	5/130	5/130
Precision version		1377966	1377973	1377980	1377986		

① It may take a few 100 gripping cycles until the full gripping force (as indicated in the data table) will be available.

Main view

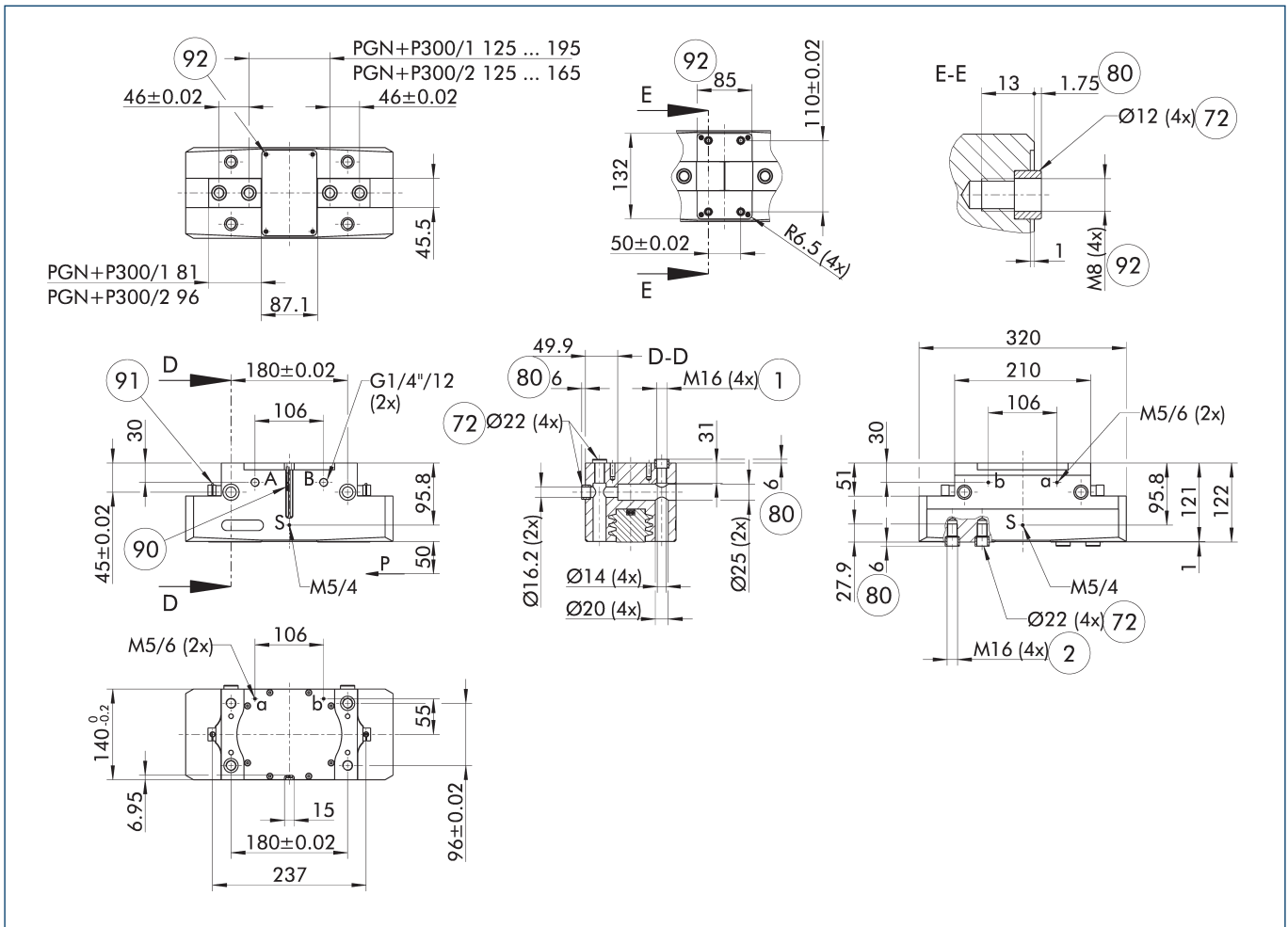

The drawing shows the gripper in the basic version with closed jaws, without dimensional consideration of the options described below.

① As an alternative/in addition to spring-assisted mechanical gripping force maintenance, the SDV-P pressure maintenance valve can be used for I.D. and O.D. gripping (see "Accessories" section of catalog).

- A, a Main / direct connection, gripper opening
- B, b Main / direct connection, gripper closing
- S Air purge connection
- ① Gripper connection
- ② Finger connection
- ⑦② Fit for centering sleeves

- ⑧① Depth of the centering sleeve hole in the counter part
- ⑨① MMS 22 sensor
- ⑨① Sensor IN ...
- ⑨② Screw connection with centering for customized mounting (these centering sleeves are not included in the scope of delivery)

PGN-plus-P 300

Universal gripper

Maximum permitted finger projection

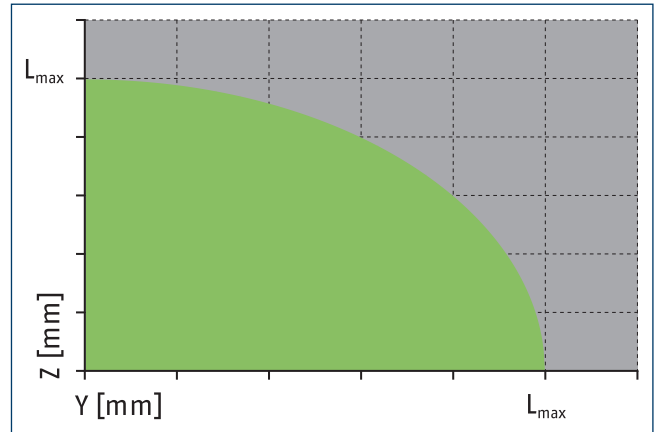
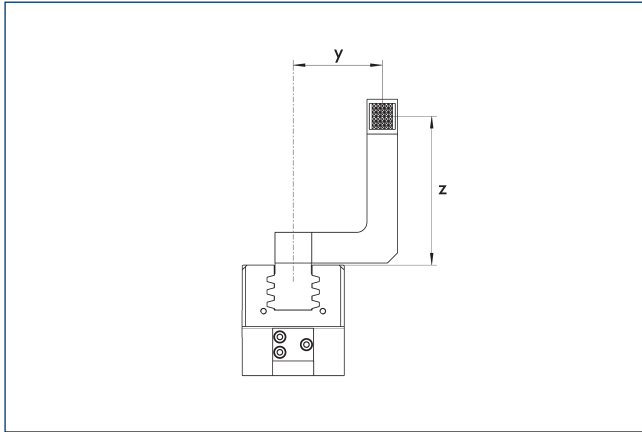

■ Permitted range

■ Inadmissible range

L_{max} is equivalent to the maximum permitted finger length, see the technical data table.

Hose-free direct connection M5

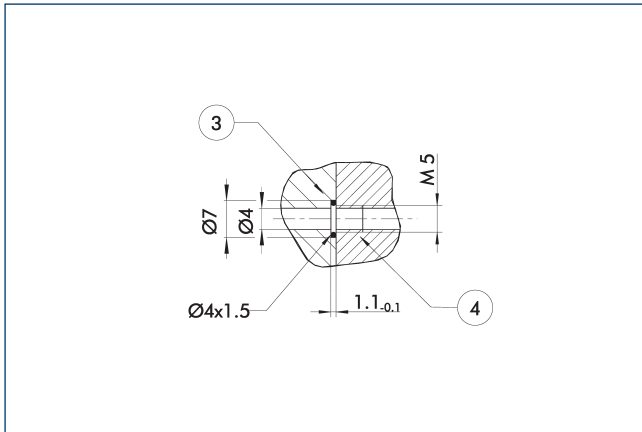

③ Adapter

④ Grippers

The direct connection is used for supplying compressed air without hoses. Instead, the pressure medium is fed through bore-holes in the mounting plate.

Gripping force maintenance version AS/IS

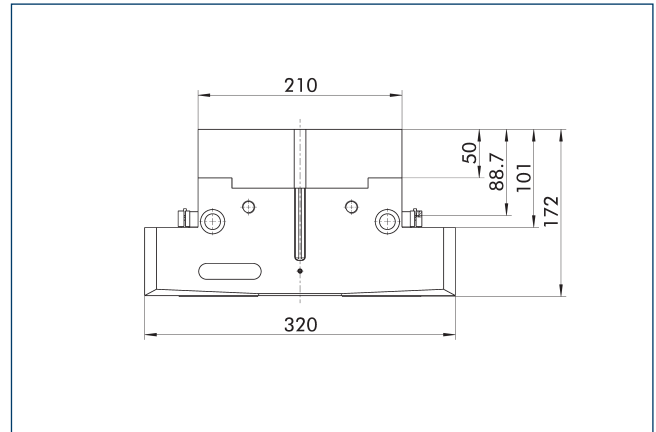

The mechanical gripping force maintenance device ensures that a minimum clamping force will be applied even if there is a drop in pressure. In the AS/S variant this acts as a closing force, in the IS variant as an opening force. Besides this, gripping force maintenance can be used to increase gripping force or for single actuated gripping.

Dustproof version

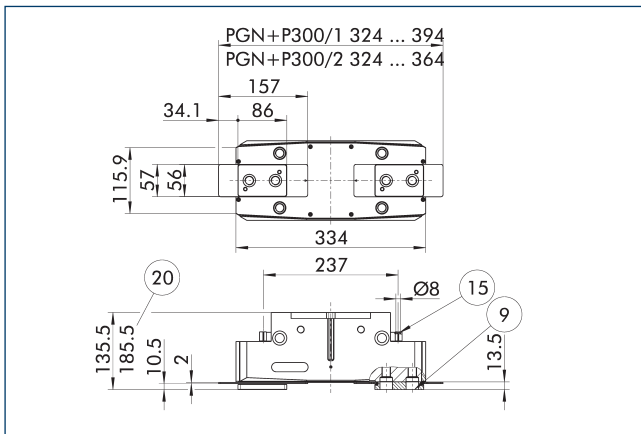

- ⑨ For mounting screw connection diagram, see basic version
- ⑮ Sealing bolt
- ⑳ For version AS/IS

The "dustproof" option increases the degree of protection against penetrating substances. The assembly diagram shifts by the height of the intermediate jaw. The finger length is still measured from the upper edge of the gripper housing.

Description	ID
Dust cover	
SAD PGN-plus-P 300	1347590

Precision version

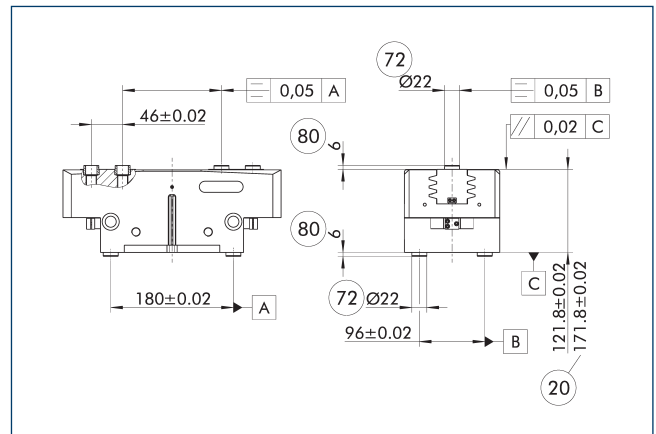

- ⑳ For version AS/IS
- ㉓ Fit for centering sleeves
- ⑧① Depth of the centering sleeve hole in the counter part

The indicated tolerances just refer to the variants of precision versions shown in the chart of technical specifications. All other variants of precision versions are available on request.

SDV-P pressure maintenance valve

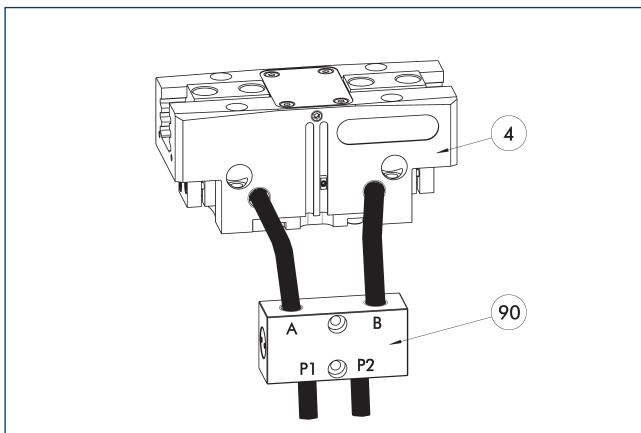

- ④ Grippers
- ⑨① SDV-P pressure maintenance valve

The SDV-P pressure maintenance valve ensures in emergency STOP situations that the pressure in the piston chamber of pneumatic gripper, swivel, linear, and quick-change modules is temporarily maintained.

Description	ID	Recommended hose diameter
		[mm]
Pressure maintenance valve		
SDV-P 07	0403131	8
Pressure maintenance valve with air bleed screw		
SDV-P 07-E	0300121	8
SDV-P 10-E	0300109	10

- ① In order to achieve the specified closing and opening time for each gripper variant, the recommended hose diameter must be used. The direct allocation of the respective variant of the gripper for the respective SDV-P can be found at schunk.com.

PGN-plus-P 300

Universal gripper

BSWS jaw quick-change jaw systems

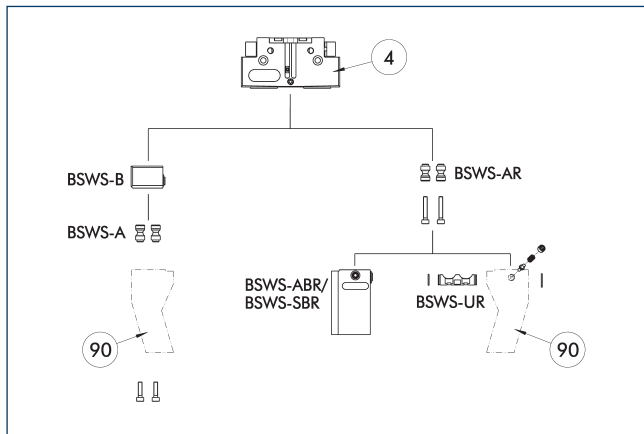

④ Grippers

⑨ Customized gripper fingers

There are various jaw quick-change systems available for the gripper. For detailed information, please refer to the corresponding product.

Description	ID	Scope of delivery
Quick-change jaw system base		
BSWS-B 300	0303037	1
Jaw quick-change system adapter pin		
BSWS-A 300	0303036	2

ⓘ If the operating pressure is higher than 6 bar, suitability for use beyond the application limits must be checked. Only systems that are listed in the table, can be used.

Fields of application

Series	Size	Variant	Suitability
PGN-plus-P	300	-1 (6 bar)	■■■■
PGN-plus-P	300	-1-AS/1-IS (6 bar)	■■□□
PGN-plus-P	300	-2 (6 bar)	■■□□
PGN-plus-P	300	-2-AS/2-IS (6 bar)	□□□□
Legend			
■■■■	Can be combined without restrictions		
■■□□	Use with restrictions (see loading limits)		
□□□□	cannot be combined		

The load limits for describing the application limits can be found in the catalog chapter of the corresponding accessories.

Finger blanks ABR/SBR-PGZN-plus 300

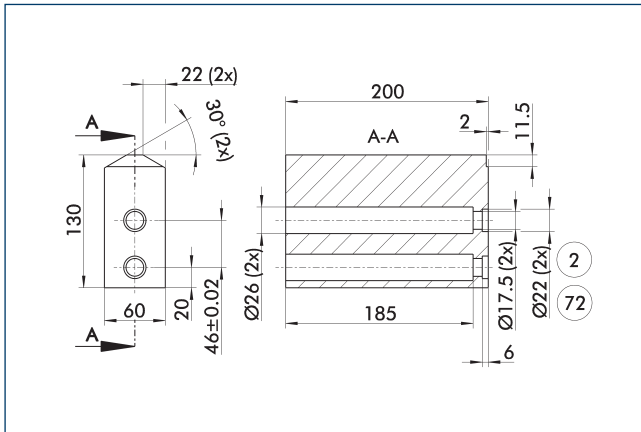

- ② Finger connection ⑦② Fit for centering sleeves

The drawing shows the finger blank which can be reworked by the customer.

Description	ID	Material	Scope of delivery
Finger blank			
ABR-PGZN-plus 300	0300016	Aluminum (3.4365)	1
SBR-PGZN-plus 300	0300026	Steel (1.7131)	1

Inductive proximity switches

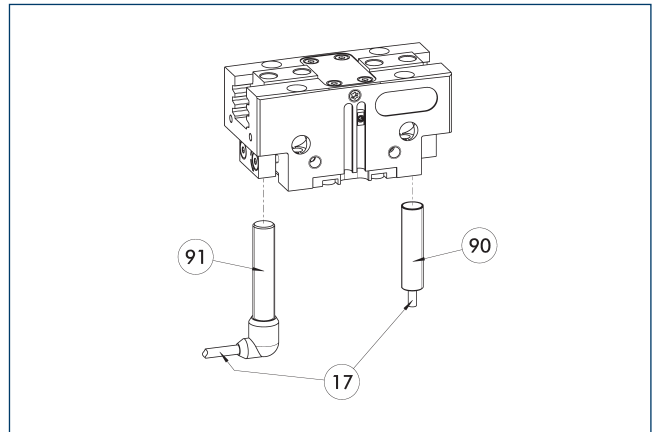

- ①⑦ Cable outlet ⑨① Sensor IN...-SA
 ⑨② Sensor IN ...

Directly mounted end position monitoring.

Description	ID	Often combined
Inductive proximity switches		
IN 80-S-M12	0301578	
IN 80-S-M8	0301478	●
INK 80-S	0301550	
Inductive proximity switch with lateral cable outlet		
IN 80-S-M12-SA	0301587	
IN 80-S-M8-SA	0301483	●
INK 80-S-SA	0301566	
Connection cables		
KA BG08-L 3P-0300-PNP	0301622	●
KA BG08-L 3P-0500-PNP	0301623	
KA BG12-L 3P-0500-PNP	30016369	
KA BW08-L 3P-0300-PNP	0301594	
KA BW08-L 3P-0500-PNP	0301502	
KA BW12-L 3P-0300-PNP	0301503	
KA BW12-L 3P-0500-PNP	0301507	
Clip for connector/socket		
CLI-M12	0301464	
CLI-M8	0301463	
Cable extension		
KV BG12-SG12 3P-0030-PNP	0301999	
KV BG12-SG12 3P-0060-PNP	0301998	
KV BW08-SG08 3P-0030-PNP	0301495	
KV BW08-SG08 3P-0100-PNP	0301496	
KV BW08-SG08 3P-0200-PNP	0301497	●
KV BW12-SG12 3P-0030-PNP	0301595	
KV BW12-SG12 3P-0100-PNP	0301596	
KV BW12-SG12 3P-0200-PNP	0301597	
Sensor distributor		
V2-M12	0301776	●
V2-M8	0301775	●
V4-M8	0301746	
V8-M8	0301751	

- ① Two sensors are required per unit for monitoring two positions. On option, extension cables and sensor distributors are available. Additional product variants of the sensor, and further information and technical data can be found in the catalog chapter sensor system.

PGN-plus-P 300

Universal gripper

Flexible position sensor

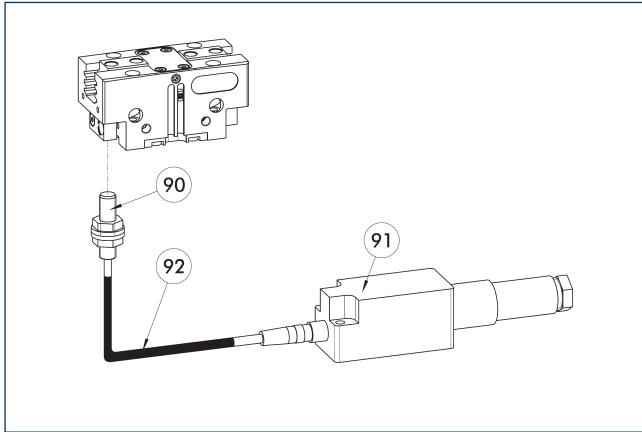

- 90 FPS-S sensor
- 91 FPS-F5 evaluation electronic
- 92 Cable extension

Flexible position monitoring of up to five positions.

Description	ID	
Attachment kit for FPS		
AS-FPS-PGN-plus-P 300-2	1395867	
Sensor		
FPS-S M8	0301704	
Evaluation electronics		
FPS-F5	0301805	
Cable extension		
KV BG08-SG08 3P-0050	0301598	
KV BG08-SG08 3P-0100	0301599	

- ① When using an FPS system, an FPS sensor (FPS-S) as well as an electronic processor (FPS-F5 / F5 T) are required for each gripper as well as a mounting kit (AS), if listed. Cable extensions (KV) are optionally available – see catalog chapter “Accessories.”

Electronic magnetic switch MMS

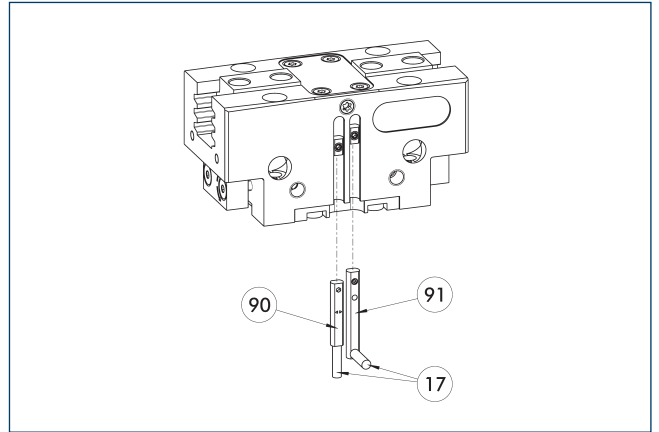

- 17 Cable outlet
- 90 Sensor MMS 22..
- 91 Sensor MMS 22...-SA

End position monitoring for mounting in the C-slot.

Description	ID	Often combined
Electronic magnetic switch		
MMS 22-S-M8-PNP	0301032	●
MMSK 22-S-PNP	0301034	
Electronic magnetic switches with lateral cable outlet		
MMS 22-S-M8-PNP-SA	0301042	●
MMSK 22-S-PNP-SA	0301044	
Connection cables		
KA BG08-L 3P-0300-PNP	0301622	●
KA BG08-L 3P-0500-PNP	0301623	
KA BW08-L 3P-0300-PNP	0301594	
KA BW08-L 3P-0500-PNP	0301502	
Clip for connector/socket		
CLI-M8	0301463	
Cable extension		
KV BW08-SG08 3P-0030-PNP	0301495	
KV BW08-SG08 3P-0100-PNP	0301496	
KV BW08-SG08 3P-0200-PNP	0301497	●
Sensor distributor		
V2-M8	0301775	●
V4-M8	0301746	
V8-M8	0301751	

- ① Two sensors are required per unit for monitoring two positions. On option, extension cables and sensor distributors are available. Additional product variants of the sensor, and further information and technical data can be found in the catalog chapter sensor system.

Programmable magnetic switch MMS 22-PI1

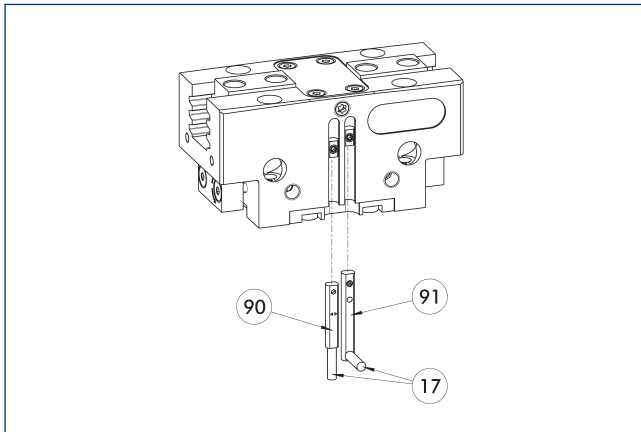

- ①⑦ Cable outlet
- ①⑨ Sensor MMS 22 ..-PI1-...-SA
- ①⑩ Sensor MMS 22 PI1-...

Position monitoring with one programmable position per sensor and integrated electronic system in the sensor. Can be programmed using MT magnetic teaching tool (included in the scope of delivery, ID 0301030) or ST plug teaching tool (optional). End position monitoring for mounting in the C-slot. If the ST plug teaching tools are listed in the table provided, teaching is only possible with the ST teaching tools.

Description	ID	Often combined
Programmable magnetic switch		
MMS 22-PI1-S-M8-PNP	0301160	●
MMSK 22-PI1-S-PNP	0301162	
Programmable magnetic switch with lateral cable outlet		
MMS 22-PI1-S-M8-PNP-SA	0301166	●
MMSK 22-PI1-S-PNP-SA	0301168	
Programmable magnetic switch with stainless steel housing		
MMS 22-PI1-S-M8-PNP-HD	0301110	●
MMSK 22-PI1-S-PNP-HD	0301112	

- ① Two sensors are required per unit for monitoring two positions. On option, extension cables and sensor distributors are available. Additional product variants of the sensor, and further information and technical data can be found in the catalog chapter sensor system.

APS-Z80 analog position sensor

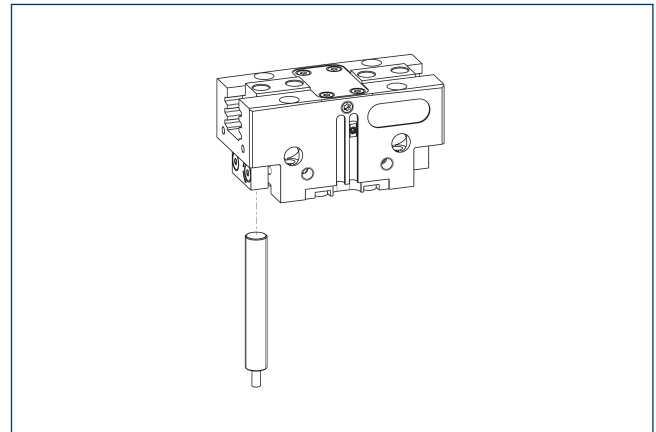

Non-contact measuring, analog multi-position monitoring for any number of positions.

Description	ID	Often combined
Mounting kit for APS-Z80		
AS-APS-Z80-PGN-plus-P 300-1	1395892	
AS-APS-Z80-PGN-plus-P 300-2	1395894	
Analog position sensor		
APS-Z80-K	0302072	
APS-Z80-M8	0302070	●

- ① When using an APS system, one mounting kit (AS-APS-Z80) and one APS-Z80 sensor is required per gripper. The resolution of the sensor can be lower in the peripheral areas of the gripper. You can find further information on the product in the operating manual.

PGN-plus-P 300

Universal gripper

APS-M1 analog position sensor

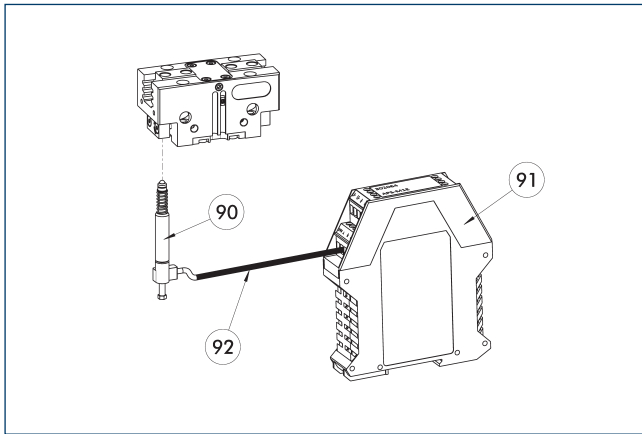

- ⑨⑩ APS-M1S sensor ⑨② APS-K extension cable
⑨① APS-M1E electronic processor

Analog multi position monitoring for any desired positions

Description	ID	
Mounting kit for APS-M1		
AS-APS-M1-PGN-plus-P 300-1	1395905	
AS-APS-M1-PGN-plus-P 300-2	1395907	
Analog position sensor		
APS-M1S	0302062	
Connection cables		
APS-K0200	0302066	
APS-K0700	0302068	
Evaluation electronics		
APS-M1E	0302064	

- ① When using an APS system, for each gripper an attachment kit (AS-APS-M1), an APS-M1S sensor (incl. 3 m cable) as well as an electronics (APS-M1e) are required. An extension cable (APS-K) can be connected between the sensor and the electronics as an option. The max. cable length between the sensor and the electronics is 10 m, between the electronics and their control unit (PLC) it is max. 1 m.

PGN-plus-P 380

Universal gripper



Gripping force O.D. gripping

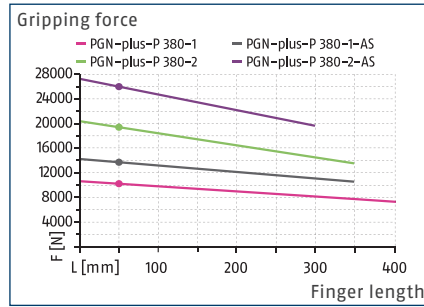

Gripping force I.D. gripping

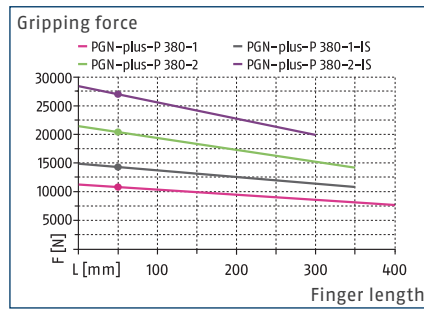

Dimensions and maximum loads

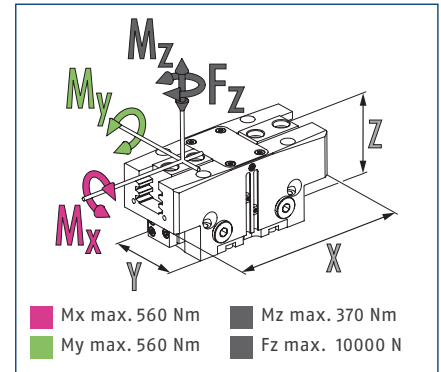

① The indicated moments and forces are static values, apply for each base jaw and may appear simultaneously. Loads may additionally occur to the moment produced by the gripping force itself.

Technical data

Description		PGN-plus-P 380-1	PGN-plus-P 380-2	PGN-plus-P 380-1-AS	PGN-plus-P 380-2-AS	PGN-plus-P 380-1-IS	PGN-plus-P 380-2-IS
ID		1378012	1378019	1378022	1378029	1378035	1378037
Stroke per jaw	[mm]	45	26	45	26	45	26
Closing/opening force	[N]	10300/10800	19500/20400	13800/-	26100/-	-/14300	-/27000
Min. spring force	[N]			3500	6600	3500	6600
Weight	[kg]	26.5	27.5	36	37	36	37
Recommended workpiece weight	[kg]	51.5	97.5	51.5	97.5	51.5	97.5
Fluid consumption double stroke	[cm³]	2275	2275	2705	2705	3175	3175
Min./nom./max. operating pressure	[bar]	2.5/6/8	2.5/6/8	4/6/6.5	4/6/6.5	4/6/6.5	4/6/6.5
Min./max. air purge pressure	[bar]	0.5/1	0.5/1	0.5/1	0.5/1	0.5/1	0.5/1
Closing/opening time	[s]	0.6/0.6	0.6/0.6	0.5/0.8	0.5/0.8	0.8/0.5	0.8/0.5
Closing/opening time with spring	[s]			0.80	0.80	0.80	0.80
Max. permissible finger length	[mm]	400	350	350	300	350	300
Max. permissible weight per finger	[kg]	17	17	17	17	17	17
IP protection class		40	40	40	40	40	40
Min./max. ambient temperature	[°C]	5/90	5/90	5/90	5/90	5/90	5/90
Repeat accuracy	[mm]	0.05	0.05	0.05	0.05	0.05	0.05
Dimensions X x Y x Z	[mm]	410 x 170 x 155	410 x 170 x 155	410 x 170 x 226.5	410 x 170 x 226.5	410 x 170 x 226.5	410 x 170 x 226.5
Options and their characteristics							
Dustproof version		1378074	1378108	1378110	1378111	1378114	1378118
IP protection class		64	64	64	64	64	64
Weight	[kg]	29.3	30.3	38.8	39.8	38.8	39.8
Corrosion-protected version		1378059	1378061	1378064	1378066	1378070	1378072
High-temperature version		1378038	1378042	1378047	1378048	1378050	1378056
Min./max. ambient temperature	[°C]	5/130	5/130	5/130	5/130	5/130	5/130
Precision version		1378120	1378124	1378128	1378130		

① It may take a few 100 gripping cycles until the full gripping force (as indicated in the data table) will be available.

Main view

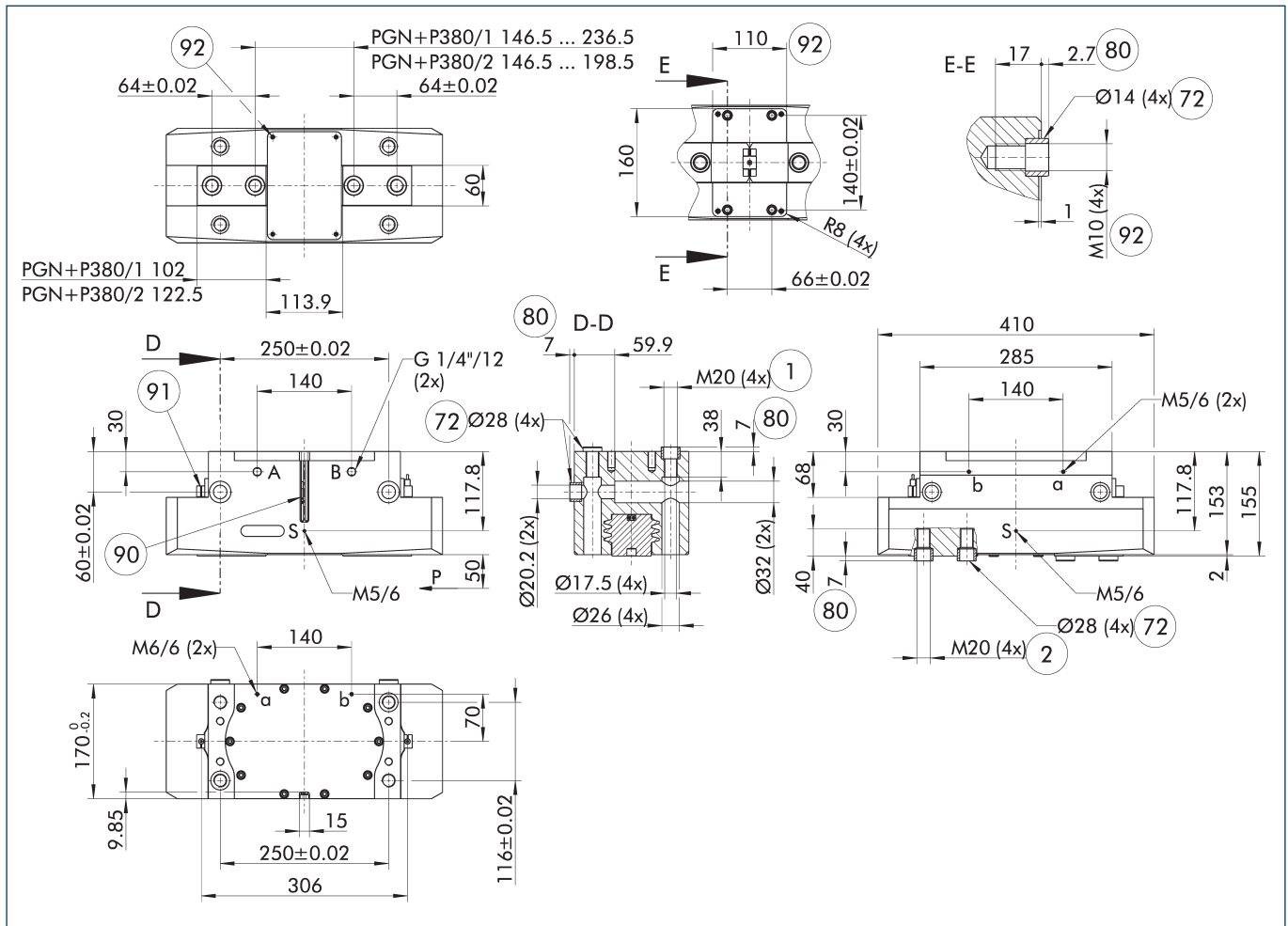

The drawing shows the gripper in the basic version with closed jaws, without dimensional consideration of the options described below.

① As an alternative/in addition to spring-assisted mechanical gripping force maintenance, the SDV-P pressure maintenance valve can be used for I.D. and O.D. gripping (see "Accessories" section of catalog).

- A, a Main / direct connection, gripper opening
- B, b Main / direct connection, gripper closing
- S Air purge connection
- ① Gripper connection
- ② Finger connection
- ⑦ Fit for centering sleeves

- ⑧ Depth of the centering sleeve hole in the counter part
- ⑨ MMS 22 sensor
- ⑩ Sensor IN ...
- ⑪ Screw connection with centering for customized mounting (these centering sleeves are not included in the scope of delivery)

PGN-plus-P 380

Universal gripper

Maximum permitted finger projection

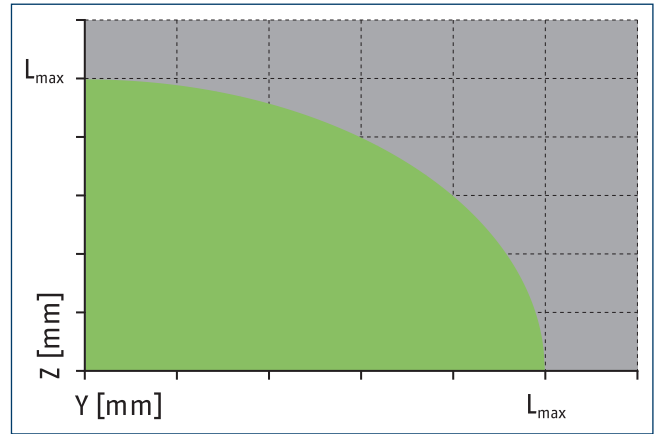
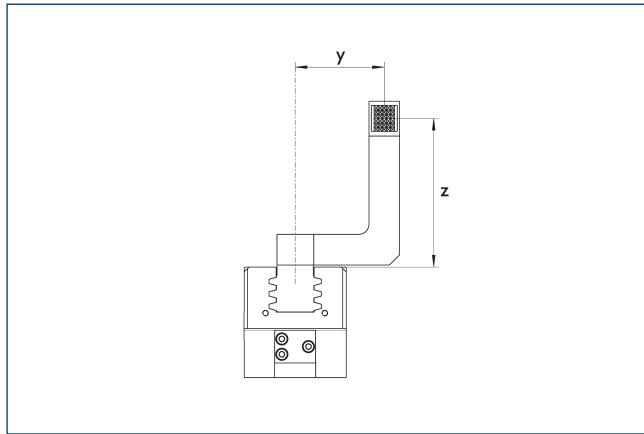

■ Permitted range ■ Inadmissible range

L_{max} is equivalent to the maximum permitted finger length, see the technical data table.

Hose-free direct connection M6

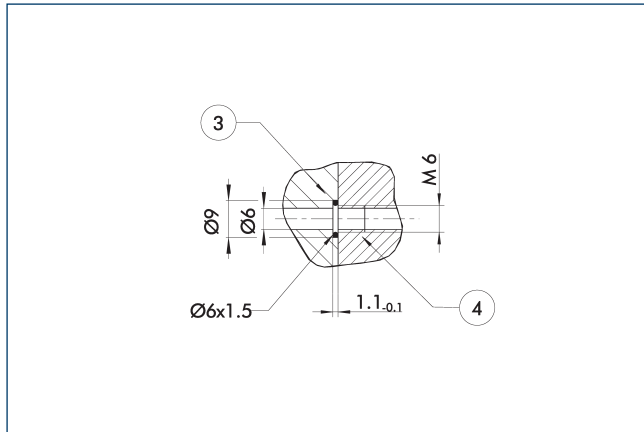

③ Adapter

④ Grippers

The direct connection is used for supplying compressed air without hoses. Instead, the pressure medium is fed through bore-holes in the mounting plate.

Gripping force maintenance version AS/IS

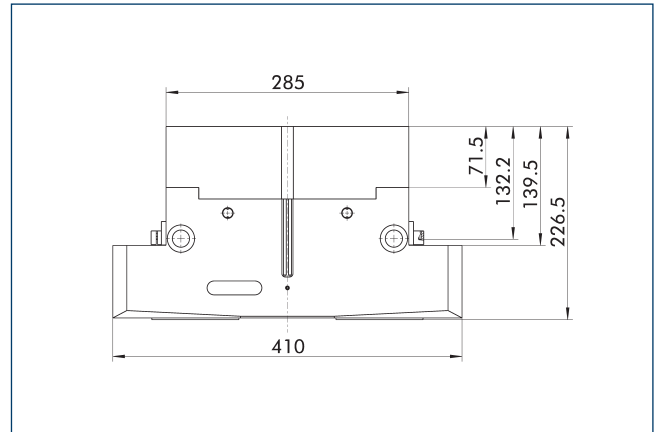

The mechanical gripping force maintenance device ensures that a minimum clamping force will be applied even if there is a drop in pressure. In the AS/S variant this acts as a closing force, in the IS variant as an opening force. Besides this, gripping force maintenance can be used to increase gripping force or for single actuated gripping.

Dustproof version

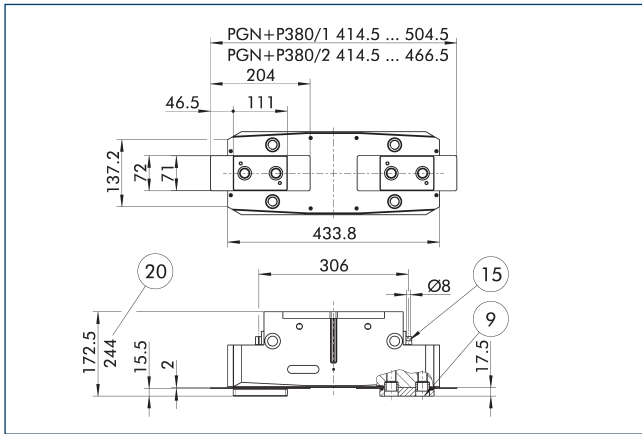

- ⑨ For mounting screw connection diagram, see basic version
- ⑮ Sealing bolt
- ⑳ For version AS/IS

The "dustproof" option increases the degree of protection against penetrating substances. The assembly diagram shifts by the height of the intermediate jaw. The finger length is still measured from the upper edge of the gripper housing.

Description	ID
Dust cover	
SAD PGN-plus-P 380	1347597

Precision version

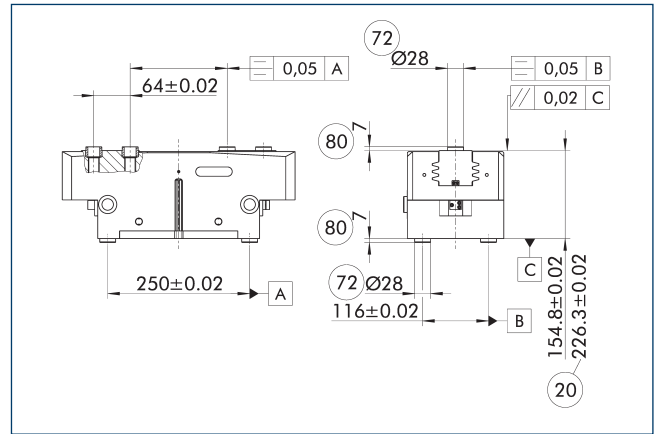

- ⑳ For version AS/IS
- ⑰ Fit for centering sleeves
- ⑸① Depth of the centering sleeve hole in the counter part

The indicated tolerances just refer to the variants of precision versions shown in the chart of technical specifications. All other variants of precision versions are available on request.

SDV-P pressure maintenance valve

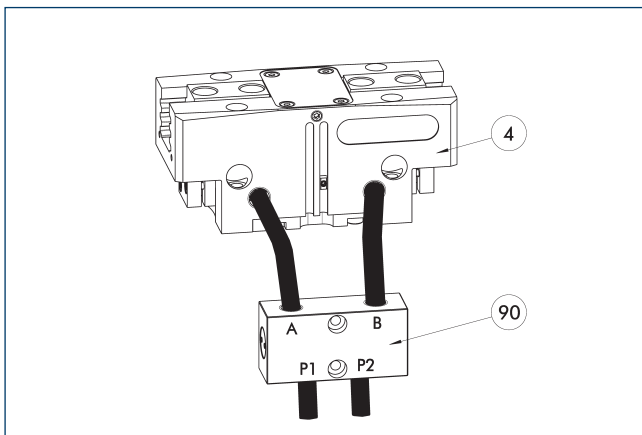

- ④ Grippers
- ⑸① SDV-P pressure maintenance valve

The SDV-P pressure maintenance valve ensures in emergency STOP situations that the pressure in the piston chamber of pneumatic gripper, swivel, linear, and quick-change modules is temporarily maintained.

Description	ID	Recommended hose diameter
		[mm]
Pressure maintenance valve with air bleed screw		
SDV-P 10-E	0300109	10

- ① In order to achieve the specified closing and opening time for each gripper variant, the recommended hose diameter must be used. The direct allocation of the respective variant of the gripper for the respective SDV-P can be found at schunk.com.

PGN-plus-P 380

Universal gripper

Inductive proximity switches

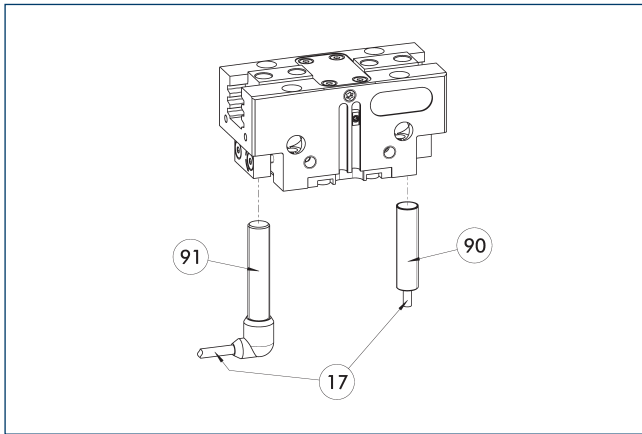

17 Cable outlet

91 Sensor IN..-SA

90 Sensor IN ...

Directly mounted end position monitoring.

Description	ID	Often combined
Inductive proximity switches		
IN 80-S-M12	0301578	
IN 80-S-M8	0301478	●
INK 80-S	0301550	
Inductive proximity switch with lateral cable outlet		
IN 80-S-M12-SA	0301587	
IN 80-S-M8-SA	0301483	●
INK 80-S-SA	0301566	
Connection cables		
KA BG08-L 3P-0300-PNP	0301622	●
KA BG08-L 3P-0500-PNP	0301623	
KA BG12-L 3P-0500-PNP	30016369	
KA BW08-L 3P-0300-PNP	0301594	
KA BW08-L 3P-0500-PNP	0301502	
KA BW12-L 3P-0300-PNP	0301503	
KA BW12-L 3P-0500-PNP	0301507	
Clip for connector/socket		
CLI-M12	0301464	
CLI-M8	0301463	
Cable extension		
KV BG12-SG12 3P-0030-PNP	0301999	
KV BG12-SG12 3P-0060-PNP	0301998	
KV BW08-SG08 3P-0030-PNP	0301495	
KV BW08-SG08 3P-0100-PNP	0301496	
KV BW08-SG08 3P-0200-PNP	0301497	●
KV BW12-SG12 3P-0030-PNP	0301595	
KV BW12-SG12 3P-0100-PNP	0301596	
KV BW12-SG12 3P-0200-PNP	0301597	
Sensor distributor		
V2-M12	0301776	●
V2-M8	0301775	●
V4-M8	0301746	
V8-M8	0301751	

① Two sensors are required per unit for monitoring two positions. On option, extension cables and sensor distributors are available. Additional product variants of the sensor, and further information and technical data can be found in the catalog chapter sensor system.

Flexible position sensor

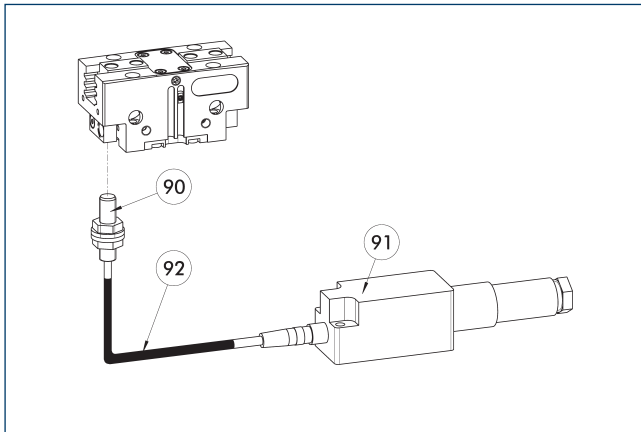

- ⑨⑩ FPS-S sensor
- ⑨② Cable extension
- ⑨① FPS-F5 evaluation electronic

Flexible position monitoring of up to five positions.

Description	ID	
Attachment kit for FPS		
AS-FPS-PGN-plus-P 380-2	1395872	
Sensor		
FPS-S M8	0301704	
Evaluation electronics		
FPS-F5	0301805	
Cable extension		
KV BG08-SG08 3P-0050	0301598	
KV BG08-SG08 3P-0100	0301599	

- ① When using an FPS system, an FPS sensor (FPS-S) as well as an electronic processor (FPS-F5 / F5 T) are required for each gripper as well as a mounting kit (AS), if listed. Cable extensions (KV) are optionally available – see catalog chapter “Accessories.”

Electronic magnetic switch MMS

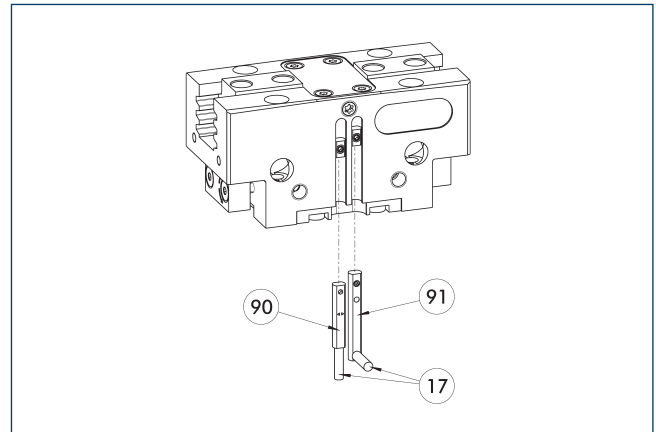

- ①⑦ Cable outlet
- ⑨① Sensor MMS 22...-SA
- ⑨⑩ Sensor MMS 22..

End position monitoring for mounting in the C-slot.

Description	ID	Often combined
Electronic magnetic switch		
MMS 22-S-M8-PNP	0301032	●
MMSK 22-S-PNP	0301034	
Electronic magnetic switches with lateral cable outlet		
MMS 22-S-M8-PNP-SA	0301042	●
MMSK 22-S-PNP-SA	0301044	
Connection cables		
KA BG08-L 3P-0300-PNP	0301622	●
KA BG08-L 3P-0500-PNP	0301623	
KA BW08-L 3P-0300-PNP	0301594	
KA BW08-L 3P-0500-PNP	0301502	
Clip for connector/socket		
CLI-M8	0301463	
Cable extension		
KV BW08-SG08 3P-0030-PNP	0301495	
KV BW08-SG08 3P-0100-PNP	0301496	
KV BW08-SG08 3P-0200-PNP	0301497	●
Sensor distributor		
V2-M8	0301775	●
V4-M8	0301746	
V8-M8	0301751	

- ① Two sensors are required per unit for monitoring two positions. On option, extension cables and sensor distributors are available. Additional product variants of the sensor, and further information and technical data can be found in the catalog chapter sensor system.

PGN-plus-P 380

Universal gripper

Programmable magnetic switch MMS 22-PI1

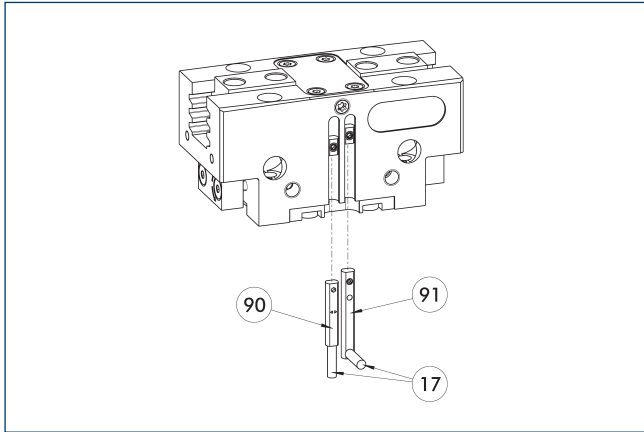

- ①⑦ Cable outlet
- ①⑨ Sensor MMS 22 ..-PI1-...-SA
- ①⑩ Sensor MMS 22 PI1-...

Position monitoring with one programmable position per sensor and integrated electronic system in the sensor. Can be programmed using MT magnetic teaching tool (included in the scope of delivery, ID 0301030) or ST plug teaching tool (optional). End position monitoring for mounting in the C-slot. If the ST plug teaching tools are listed in the table provided, teaching is only possible with the ST teaching tools.

Description	ID	Often combined
Programmable magnetic switch		
MMS 22-PI1-S-M8-PNP	0301160	●
MMSK 22-PI1-S-PNP	0301162	
Programmable magnetic switch with lateral cable outlet		
MMS 22-PI1-S-M8-PNP-SA	0301166	●
MMSK 22-PI1-S-PNP-SA	0301168	
Programmable magnetic switch with stainless steel housing		
MMS 22-PI1-S-M8-PNP-HD	0301110	●
MMSK 22-PI1-S-PNP-HD	0301112	

- ① Two sensors are required per unit for monitoring two positions. On option, extension cables and sensor distributors are available. Additional product variants of the sensor, and further information and technical data can be found in the catalog chapter sensor system.

APS-Z80 analog position sensor

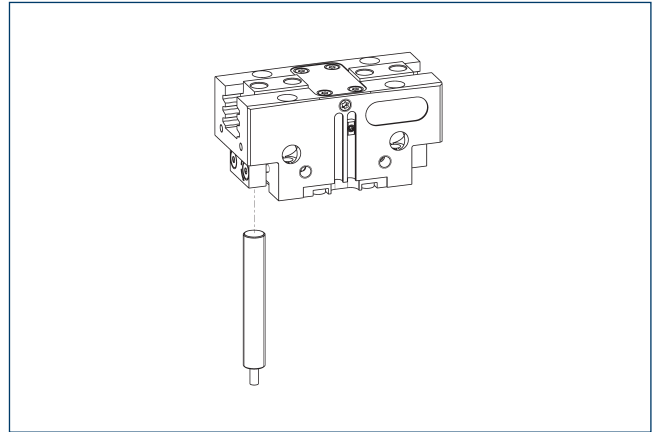

Non-contact measuring, analog multi-position monitoring for any number of positions.

Description	ID	Often combined
Mounting kit for APS-Z80		
AS-APS-Z80-PGN-plus-P 380-1	1395900	
AS-APS-Z80-PGN-plus-P 380-2	1395903	
Analog position sensor		
APS-Z80-K	0302072	
APS-Z80-M8	0302070	●

- ① When using an APS system, one mounting kit (AS-APS-Z80) and one APS-Z80 sensor is required per gripper. The resolution of the sensor can be lower in the peripheral areas of the gripper. You can find further information on the product in the operating manual.

APS-M1 analog position sensor

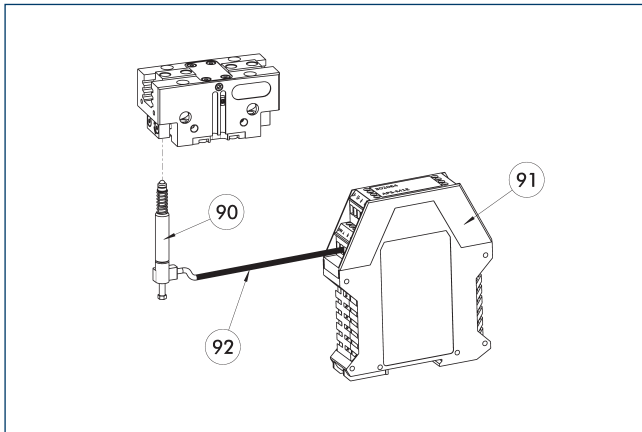

- ⑨⑩ APS-M1S sensor
- ⑨① APS-M1E electronic processor
- ⑨② APS-K extension cable

Analog multi position monitoring for any desired positions

Description	ID	
Mounting kit for APS-M1		
AS-APS-M1-PGN-plus-P 380-1	1395912	
AS-APS-M1-PGN-plus-P 380-2	1395916	
Analog position sensor		
APS-M1S	0302062	
Connection cables		
APS-K0200	0302066	
APS-K0700	0302068	
Evaluation electronics		
APS-M1E	0302064	

- ① When using an APS system, for each gripper an attachment kit (AS-APS-M1), an APS-M1S sensor (incl. 3 m cable) as well as an electronics (APS-M1e) are required. An extension cable (APS-K) can be connected between the sensor and the electronics as an option. The max. cable length between the sensor and the electronics is 10 m, between the electronics and their control unit (PLC) it is max. 1 m.



SCHUNK GmbH & Co. KG
Spann- und Greiftechnik

Bahnhofstr. 106 - 134
D-74348 Lauffen/Neckar
Tel. +49-7133-103-0
Fax +49-7133-103-2399
info@de.schunk.com
schunk.com

Folgen Sie uns | *Follow us*

